

TYPICAL CONCRETE STREET OR DRIVEWAY (REPLACE FULL PANELS)
 STD. PAY WIDTH = STD. TRENCH WIDTH + 2 FT.

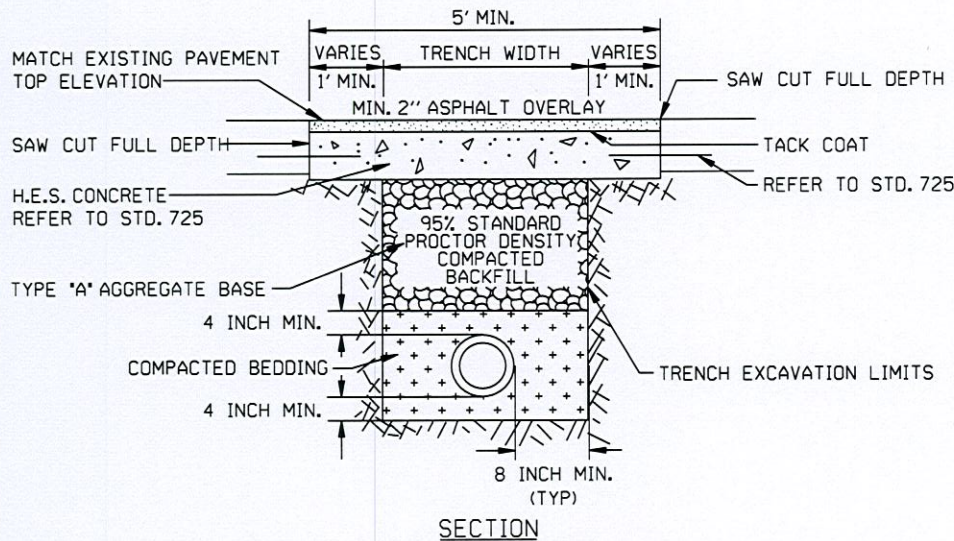

TYPICAL CONCRETE WITH 2" ASPHALT OVERLAY
 FOR ASPHALT OR CONCRETE/ASPHALT STREETS
 STD. PAY WIDTH = STD. TRENCH + 2 FT.

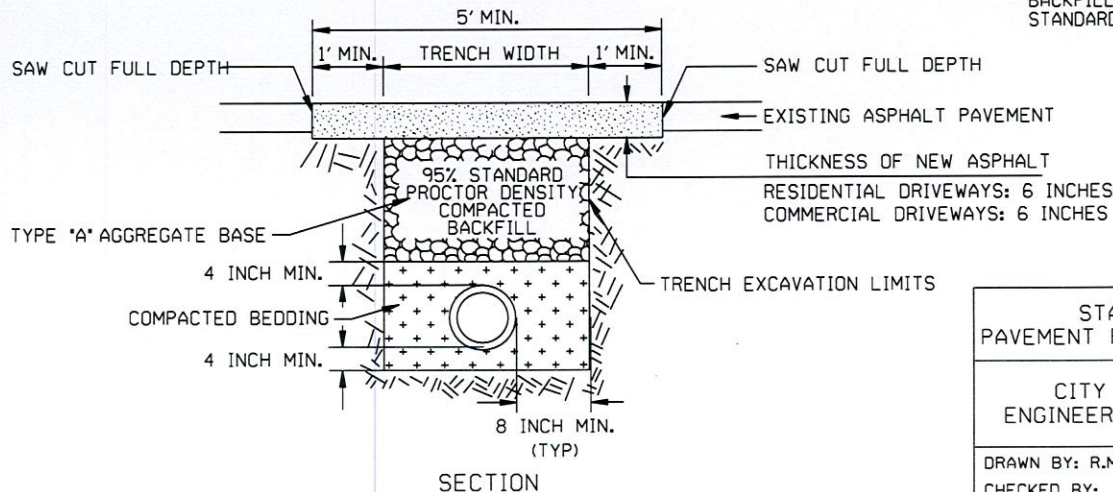

TYPICAL ASPHALT DRIVEWAY OR PARKING LOT
 STD. PAY WIDTH = STD. TRENCH WIDTH + 2 FT.

NOTE:

- 1A. BEDDING MATERIAL WITHIN 4 INCHES OF FLEXIBLE GRAVITY PIPE SHALL BE COMPACTED 3/4' TO NO. 4 CRUSHED STONE (GRAD NO. 67).
- 1B. BEDDING MATERIAL FOR RIGID AND SEMI-RIGID PIPE SHALL BE AS NOTED IN STDS. 304, 305 AND 751.
2. REMOVE AND REPLACE PAVEMENT TO NEAREST JOINT IF PROPOSED SAW CUT IS LESS THAN 5 FEET FROM JOINT.
3. NO PAYMENT WILL BE MADE FOR REPLACEMENT OF PAVEMENT OUTSIDE OF STANDARD PAY WIDTH DUE TO TRENCH EXCAVATION WIDER THAN STANDARD TRENCH WIDTH.
4. PAY QUANTITY WILL INCLUDE REPLACEMENT OF PAVEMENT DUE TO SQUARING OF DIAGONAL CUTS.
5. WHERE TRENCH EXCAVATION IS WITHIN 12" OF BACK OF CURB, COMPACTED BACKFILL SHALL BE ODOT TYPE 'A' AGGREGATE BASE.
6. SEE STD. 731 FOR MINIMUM PAVING PANEL DIMENSIONS.
7. THE MAXIMUM RATIO OF PAVING PANEL DIMENSIONS SHALL BE 1.5:1
8. JOINT SHALL NOT BE PLACED IN VEHICLE WHEEL PATH.
9. FOR ASPHALT DIMENSIONS AND TYPE REFER TO STD. 725.
10. FOR FLOWABLE FILL BEDDING AND BACKFILL ALTERNATIVES REFER TO STANDARDS 730 AND 731.

STANDARD DETAIL FOR
 PAVEMENT REMOVAL AND REPLACEMENT
 CITY OF TULSA, OKLAHOMA
 ENGINEERING SERVICES DEPARTMENT

DRAWN BY: R.M.O.
 CHECKED BY:
 DATE: APRIL 2019

APPROVED

 STANDARD NO. 713

NOT TO SCALE