



**Invitation For Bid IFB 20-822A  
Grapple Bulky Waste Truck  
Streets & Stormwater  
Issued: June 18, 2020**

**City of Tulsa,  
Oklahoma**  
Page 1 of 31

NOTICE is hereby given that the CITY OF TULSA, OKLAHOMA will receive sealed Bids for the following:

**BID # IFB 20-822A**

**DESCRIPTION: Grapple Bulky Waste Truck**

**(Commodity Code(s): 065-05; 072-08)**

You are invited to submit a Bid to supply the Goods and/or Services specified above. Invitations for Bid (IFB) will be posted on the City's website at [www.cityoftulsapurchasing.org](http://www.cityoftulsapurchasing.org) or a hardcopy may be obtained at:

City of Tulsa-Purchasing Division  
175 East 2<sup>nd</sup> Street, 15<sup>th</sup> Floor  
Tulsa Oklahoma 74103

**Bids must be received no later than 5:00 PM (CST) on Wednesday, July 15, 2020, and delivered to:  
City Clerk's Office  
175 East 2<sup>nd</sup> Street, Suite 260  
Tulsa Oklahoma 74103**

Bids must be sealed and either mailed or delivered. No faxed or emailed Bids will be considered. Bids received after the stated date and time **will not be accepted and will be returned to the Bidder unopened.**

The Bid Packet consists of (1) this Notice of Invitation for Bid, (2) the Summary Sheet, (3) Form #1, (4) Form #2, (5) Form #3, (6) Form #4, (7) Form #5, (8) Form #6, (9) the Instructions, Terms and Conditions for Bidders, (10) Special Requirements, (11) Technical Specifications and (12) Exhibit A.

Use this checklist to ensure you have properly read and completed all Forms.

- Notice of Invitation for Bid
- Summary Sheet
- Form #1: Bidder Information Sheet. Must be completed.
- Form #2: Purchase Agreement. **Complete legal name in first paragraph and Notice provision in Section 17.i. Original signature required.**
- Form #3: Interest Affidavit. Original signature and notarization required.
- Form #4: Non-Collusion Affidavit. Original signature and notarization required.
- Form #5: Affidavit of Claimant. Original signature and notarization required.
- Form #6: Acknowledgment of Receipt of Addenda/Amendments. Must be completed and signed.
- Instructions, Terms and Conditions for Bidders
- Special Requirements (Offer Period; Insurance and Bonding; References)
- Technical Specifications
- Exhibit A: Bid Form including Delivery and Pricing. This is your Bid. It must be completed or your Bid will be rejected.

**IMPORTANT NOTE: Write the Bid Number, Bid Description (as listed above), and Bid Opening Date on the lower left corner of the outside of your Bid envelope. You must return the entire completed Bid Packet.**



**Invitation For Bid IFB 20-822A  
Grapple Bulky Waste Truck  
Streets & Stormwater  
Issued: June 18, 2020**

**City of Tulsa,  
Oklahoma**  
Page 2 of 31

**SUMMARY SHEET**

**Project Buyer**

If you have any questions or need additional information, contact the assigned Project Buyer:

Ashleigh McCarn  
[amccarn@cityoftulsa.org](mailto:amccarn@cityoftulsa.org)  
City of Tulsa  
175 E. 2nd Street, 15TH Floor  
Tulsa, OK 74103  
Include **IFB 20-822A** on the subject line

**Bidder's Notice of Intent to Submit a Bid**

Email the Project Buyer indicating your intent to Bid. Include IFB **IFB 20-822A Grapple Bulky Waste Truck** on the subject line of the email. You will receive an email response verifying your notice of intent to bid was received. This same procedure should be followed to request clarification, in writing, of any point in the IFB. Bidders are encouraged to contact the Project Buyer by email if there is anything in these specifications that prevents you from submitting a Bid, or completing the Bid Packet.

Questions and concerns must be received no later than **ten (10) days prior** to the Bid Packet due date.

**Issuing of Addenda**

If you received the notice of this IFB from the City as a result of being registered to sell the commodity code(s) on this Bid, you should also receive notice of any addenda issued. If you are not registered with the City to sell the commodities listed herein, you must register as a supplier on the City of Tulsa Purchasing website ([www.cityoftulsapurchasing.org](http://www.cityoftulsapurchasing.org)) to receive notice of any addenda, or to receive notice of any future IFBs.

**Pre-Bid Conference**

If a pre-Bid conference will be held for this IFB, information on that conference will be inserted below:

No pre-Bid conference will be held for this IFB.

**Bid Packet Submission**

The City requires two completed Bid packets: 1 Original and 1 Copy. Each must be clearly labeled on the front sheet indicating "Original" or "Copy". If a copy on electronic media is also required, the line below will be checked.  
\_\_\_Electronic USB Copy also required.

Responses to this Invitation for Bid must be made on the forms listed on page 1. The entire completed Bid Packet must be returned or your Bid may be rejected. Do not take exception to any portion of this Bid Packet. Do not make any entries except where required. Do not insert any other documents into the Bid Packet.

**Bid Opening**

All Bid openings are public and take place at 8:30 a.m. Thursday, the day after Bids are due. The Bid openings are held in the City of Tulsa Council Meeting Room, 175 East 2<sup>nd</sup> Street, 2<sup>nd</sup> Floor, Tulsa, Oklahoma.



**CITY OF**  
**Tulsa**  
A New Kind of Energy.

**Invitation For Bid IFB 20-822A  
Grapple Bulky Waste Truck  
Streets & Stormwater  
Issued: June 18, 2020**

**City of Tulsa,  
Oklahoma**  
Page 3 of 31

**FORM #1  
BIDDER INFORMATION SHEET**

**Bidder's Exact Legal Name:** \_\_\_\_\_  
(Must be Bidder's company name as reflected on its organizational documents, filed with the state in which bidder is organized; not simply a DBA)

**State of Organization:** \_\_\_\_\_

**Bidder's Type of Legal Entity: (check one)**

- |  |  |
|--|--|
| <input type="checkbox"/> Sole Proprietorship | <input type="checkbox"/> Limited Liability Company     |
| <input type="checkbox"/> Partnership         | <input type="checkbox"/> Limited Liability Partnership |
| <input type="checkbox"/> Corporation         |  |
| <input type="checkbox"/> Limited Partnership | <input type="checkbox"/> Other: _____                  |

**Bidder's Address:** \_\_\_\_\_  
Street City State Zip Code

**Bidder's Website Address:** \_\_\_\_\_ **Email Address:** \_\_\_\_\_

**Sales Contact:**

Name: \_\_\_\_\_  
Street: \_\_\_\_\_  
City: \_\_\_\_\_  
State: \_\_\_\_\_  
Phone: \_\_\_\_\_  
Fax: \_\_\_\_\_  
Email: \_\_\_\_\_

**Legal or Alternate Sales Contact:**

Name: \_\_\_\_\_  
Street: \_\_\_\_\_  
City: \_\_\_\_\_  
State: \_\_\_\_\_  
Phone: \_\_\_\_\_  
Fax: \_\_\_\_\_  
Email: \_\_\_\_\_



**Invitation For Bid IFB 20-822A  
Grapple Bulky Waste Truck  
Streets & Stormwater  
Issued: June 18, 2020**

**City of Tulsa,  
Oklahoma**  
Page 4 of 31

**FORM #2 (Page 1 of 4)  
PURCHASE AGREEMENT**

**INSTRUCTIONS:** This document **must** be properly signed and returned or your Bid will be **rejected**. This form constitutes your offer and if accepted by the City of Tulsa will constitute the Purchase Agreement under which you are obligated to perform. Your signature on this document indicates you have read and understand these terms and agree to be bound by them.

**THIS PURCHASE AGREEMENT** is between the CITY OF TULSA, OKLAHOMA, a municipal corporation, 175 East 2<sup>nd</sup> Street, Tulsa, Oklahoma, 74103-3827 (the "City") and:

(Bidder's company name as reflected on its organizational documents, filed with the state in which bidder is organized; not simply a DBA) (the "Seller").

**WITNESSETH:**

WHEREAS, the City has approved certain specifications and advertised for or solicited Bids on the following goods or services:

**IFB 20-822A Grapple Bulky Waste Truck**

(the "Goods and/or Services"); and

WHEREAS, Seller desires to provide such Goods and/or Services to City, acknowledges that this document constitutes Seller's offer to provide the Goods and/or Services specified below, and further acknowledges that if executed by the City's Mayor, this document will become the Purchase Agreement for such Goods and/or Services.

NOW, THEREFORE, for and in consideration of the terms, covenants and conditions hereinafter set forth, the parties hereto agree as follows:

- Documents Comprising the Agreement.** The Bid Packet includes the Notice of Invitation to Bid, the Summary Sheet, Form #1, Form #2, Form #3, Form #4, Form #5, Form #6, the Instructions, Terms and Conditions for Bidders, the Special Requirements, the Technical Specifications, Exhibit A and any addenda or amendments to the Bid Packet. The Bid Packet is incorporated herein by this reference. In the event of conflicting or ambiguous language between this Purchase Agreement and any of the other Bid Packet documents, the parties shall be governed first according to this Purchase Agreement and second according to the remainder of the documents included in the Bid Packet. Seller may submit as part of its Bid additional materials or information to support the Bid. Additional materials or information submitted by Seller which are not ambiguous and which do not conflict with this Purchase Agreement or the other Bid Packet documents are incorporated herein by this reference.
- Purchase and Sale.** Seller agrees to sell City the Goods and/or Services for the price and upon the delivery terms set forth in Exhibit A hereto. City agrees to pay Seller the price as set forth in Exhibit A based on (a) the quantity actually purchased in the case of goods or services priced by unit, or (b) the total price for a stated quantity of goods or services, upon (i) delivery of the Goods and/or Services to the City, (ii) the City's Acceptance thereof, and (iii) Seller's submission and City's approval of a verified claim for the amount due. City shall not pay any late charges or fees.
- Irrevocable Offer.** Seller understands and acknowledges that its signature on this Agreement constitutes an irrevocable offer to provide the Goods and/or Services. There is no contract unless and until City's Mayor/Mayor Pro Tem executes this Agreement accepting Seller's Bid. No City officer, employee or agent except the Mayor (or Mayor Pro Tem) has the authority to award contracts or legally obligate the City to any contract. Seller shall not provide any Goods and/or Services to City pursuant to this Agreement before this Agreement is executed by City. If Seller provides any Goods and/or Services to City pursuant to this Agreement before this Agreement is executed by City, such Goods and/or Services are provided at Seller's risk and City shall have no obligation to pay for any such Goods and/or Services.
- Term.** The term of this Agreement shall be effective commencing on the date of execution of this Agreement by the Mayor/Mayor Pro Tem of the City of Tulsa and terminating one year from that date. Seller understands and acknowledges that any future contracts or renewals are neither automatic nor implied by this Agreement. The continuing purchase by City of the Goods and/or Services set forth in this Agreement is subject to City's needs and to City's annual appropriation of sufficient funds in City's fiscal year (July 1<sup>st</sup> to June 30<sup>th</sup>) in which such Goods and/or Services are purchased. In the event City does not appropriate or budget sufficient funds to perform this Agreement, this Agreement shall be null and void without further action by City.
- Warranties.** Seller shall assure that the Goods and/or Services purchased hereunder are covered by all available and applicable manufacturers' warranties for such Goods and/or Services. Seller expressly agrees that it will be responsible for performing all warranty obligations set forth in the Technical Specifications for the Goods and/or Services covered in this Agreement. Seller also warrants that the Goods and/or Services will conform to the Technical Specifications and Special Requirements, and further warrants that the Goods and/or Services shall be of good materials and workmanship and free from defects for either a minimum of one (1) year from the date of Acceptance or installation by City, whichever is later, or as **specified in the Technical Specifications**, whichever is later. In no event shall Seller be allowed to disclaim or otherwise limit the express warranties set forth herein.
- Warranty Remedies.** City shall notify Seller if any of the Goods and/or Services fails to meet the warranties set forth above, and Seller shall promptly correct, repair or replace such Goods and/or Services at Seller's sole expense. Notwithstanding the foregoing, if such Goods and/or Services shall be determined by City to be defective or non-conforming within the first thirty (30) days after the date of Acceptance by City, then City at its option shall be entitled to a complete refund of the purchase price and, in the case of Goods, shall promptly return such Goods to Seller. Seller shall pay all expenses related to the return of such Goods to Seller.



**Invitation For Bid IFB 20-822A  
Grapple Bulky Waste Truck  
Streets & Stormwater  
Issued: June 18, 2020**

**City of Tulsa,  
Oklahoma**  
Page 5 of 31

**FORM #2 (Page 2 of 4)  
PURCHASE AGREEMENT**

- 7. **Seller Bears Risk.** The risk of loss or damage shall be borne by Seller at all times until the Acceptance of the Goods or Services by City.
- 8. **No Indemnification by City.** Seller understands and acknowledges that City is a municipal corporation that is funded by its taxpayers to operate for the benefit of its citizens. Accordingly, and pursuant to Oklahoma law, City shall not indemnify nor hold Seller harmless for loss, damage, expense or liability arising from or related to this Agreement, including any attorneys' fees and costs. In addition, Seller shall not limit its liability to City for actual loss or direct damages for any claim based on a material breach of this Agreement and the documents incorporated herein. City reserves the right to pursue all legal and equitable remedies to which it may be entitled.
- 9. **Indemnification by Seller.** Seller agrees to indemnify, defend, and save harmless City and its officers, employees and agents from all suits and actions of any nature brought against them due to the use of patented appliances, products or processes provided by Seller hereunder. Seller shall pay all royalties and charges incident to such patents.
- 10. **No Insurance by City.** If City is leasing Goods herein, City shall not be required to obtain insurance for Seller's property. Seller shall be solely responsible for any insurance it deems necessary. City is self-insured for its own negligence, subject to the limits of the Governmental Tort Claims Act (51 O.S. § 151 et seq.).
- 11. **No Confidentiality.** Seller understands and acknowledges that City is subject to the Oklahoma Open Records Act (51 O.S. §24A.1 et seq.) and therefore cannot assure the confidentiality of contract terms or other information provided by Seller pursuant to this Agreement that would be inconsistent with City's compliance with its statutory requirements thereunder.
- 12. **Non-Responsive Bids.** Seller understands and acknowledges that if it adds terms and conditions to its Bid that are different from the terms set forth herein that its Bid may be rejected as non-responsive. Furthermore, if City accepts Seller's Bid and awards a contract to Seller based on such Bid, City shall not be bound to any exceptions, changes or additions made by Seller, and any terms and conditions added by Seller which are not expressly agreed to by City in writing will be void and of no force and effect and the parties will be governed according to the document precedence set forth in Section 1 above.
- 13. **Compliance with Laws.** Seller shall be responsible for complying with all applicable federal, state and local laws, regulations and standards. Seller is responsible for any costs of such compliance. Seller certifies that it and all of its subcontractors to be used in the performance of this Purchase Agreement are in compliance with 25 O.S. Sec. 1313 and participate in the Status Verification System. The Status Verification System is defined in 25 O.S. Sec. 1312 and includes but is not limited to the free Employee Verification Program (E-Verify) available at [www.dhs.gov/E-Verify](http://www.dhs.gov/E-Verify).
- 14. **Termination.** City, by written notice, may terminate this Agreement, in whole or in part, when such action is in the best interest of City. If this Agreement is so terminated, City shall be liable only for payment for Goods accepted and Services rendered prior to the effective date of termination. City's right to terminate this Agreement is cumulative to any other rights and remedies provided by law or by this Agreement.
- 15. **Price Changes.** The parties understand and agree that the variables in Seller's cost of performance may fluctuate, but any change in Seller's cost of performance will not alter its obligations under this Agreement, nor excuse performance or delay on Seller's part. If the IFB provides that Seller may include a price escalation provision in its Bid, Seller's price escalation provision will be evaluated by City as part of Seller's Bid price when awarding the Bid.
- 16. **Right to Audit.** The parties agree that Seller's books, records, documents, accounting procedures, practices, price lists or any other items related to the Goods and/or Services provided hereunder are subject to inspection, examination, and copying by City or its designees. Seller is required to retain all records related to this Agreement for the duration of the term of this Agreement and a period of three years following completion and/or termination of the Agreement. If an audit, litigation or other action involving such records begins before the end of the three year period, the records shall be maintained for three years after the date that all issues arising out of the action are resolved or until the end of the three year retention period, whichever is later.
- 17. **Notice.** Any notice, demand, or request required by or made pursuant to this Agreement shall be deemed properly made if personally delivered in writing or deposited in the United States mail, postage prepaid, to the addresses specified below.

i. To Seller: \_\_\_\_\_  
 \_\_\_\_\_  
 \_\_\_\_\_

To CITY: City Clerk  
 CITY OF TULSA, OKLAHOMA  
 175 E. 2<sup>nd</sup> Street, Suite 260  
 Tulsa, Oklahoma 74103

With a copy to: Ashleigh McCarn, Senior Buyer  
 City of Tulsa  
 175 E. 2nd Street, 15TH Floor  
 Tulsa, OK 74103



**Invitation For Bid IFB 20-822A  
Grapple Bulky Waste Truck  
Streets & Stormwater  
Issued: June 18, 2020**

**City of Tulsa,  
Oklahoma**  
Page 6 of 31

**FORM #2 (Page 3 of 4)  
PURCHASE AGREEMENT**

18. **Relationship of Parties.** The Seller is, and shall remain at all times, an independent contractor with respect to activities and conduct while engaged in the performance of services for the City under this Agreement. No employees, subcontractors or agents of the Seller shall be deemed to be employees of the City for any purpose whatsoever, and none shall be eligible to participate in any benefit program provided by the City for its employees. The Seller shall be solely responsible for the payment of all employee wages and salaries, taxes, withholding, payments, fringe benefits, insurance premiums, continuing education courses, materials or related expenses on behalf of its employees, subcontractors, and agents. Nothing in this Agreement shall be construed to create a partnership, joint venture, or agency relationship among the parties. No party shall have any right, power or authority to act as a legal representative of another party, and no party shall have any power to obligate or bind another party, or to make any representations, express or implied, on behalf of or in the name of the other in any manner or for any purpose whatsoever.
19. **Third Parties.** This Agreement is between City and Seller and creates no right unto or duties to any other person. No person is or shall be deemed a third party beneficiary of this Agreement.
20. **Time of Essence.** City and Seller agree that time is deemed to be of the essence with respect to this Agreement.
21. **Binding Effect.** This Agreement shall be binding upon City and Seller and their respective successors, heirs, legal representatives and permitted assigns.
22. **Headings.** The headings used herein are for convenience only and shall not be used in interpreting this Agreement
23. **Severability Provision.** If any term or provision herein is determined to be illegal or unenforceable, the remainder of this Agreement will not be affected thereby. It is the intention of the parties that if any provision is held to be illegal, invalid or unenforceable, there will be added in lieu thereof a provision as similar in terms to such provision as is possible to be legal, valid and enforceable.
24. **Governing Law And Venue.** This Agreement is executed in and shall be governed by and construed in accordance with the laws of the State of Oklahoma without regard to its choice of law principles, which shall be the forum for any lawsuits arising under this Agreement or incident thereto. The parties stipulate that venue is proper in a court of competent jurisdiction in Tulsa County, Oklahoma and each party waives any objection to such venue. City does not and will not agree to binding arbitration of any disputes.
25. **No Waiver.** A waiver of any breach of any provision of this Agreement shall not constitute or operate as a waiver of any other provision, nor shall any failure to enforce any provision hereof operate as a waiver of the enforcement of such provision or any other provision.
26. **Entire Agreement/No Assignment.** This Agreement and any documents incorporated herein constitute the entire agreement of the parties and supersede any and all prior agreements, oral or otherwise. This Agreement may only be modified or amended in a writing signed by both parties. Notwithstanding anything to the contrary stated herein or in the attachments to this Agreement, no future agreements, revisions or modifications that may be required under this Agreement are effective or enforceable unless such terms, revisions or modifications have been reduced to writing and signed by City and Seller. Seller may not assign this Agreement or use subcontractors to provide the Goods and/or Services without City's prior written consent. Seller shall not be entitled to any claim for extras of any kind or nature.
27. **Multiple Counterparts.** This Agreement may be executed in several counterparts, each of which shall be deemed an original, but which together shall constitute one and the same instrument.
28. **Interpretive Matters and Definitions.** The following interpretive matters shall be applicable to this Agreement:  
28.1 Unless the context otherwise requires: (a) all references to Sections are to Sections of or to this Agreement; (b) each term defined in this Agreement has the meaning assigned to it; (c) "or" is disjunctive but not necessarily exclusive; (d) words in a singular include the plural and vice versa. All references to "\$" or to dollar amounts shall be in lawful currency of the United States of America;  
28.2 No provision of this Agreement will be interpreted in favor of, or against, any of the parties hereto by reason of the extent to which such party or its counsel participated in the drafting thereof or by reason of the extent to which any such provision is inconsistent with any prior draft hereof or thereof;  
28.3 Any reference to any applicable laws shall be deemed to refer to all rules and regulations promulgated thereunder and judicial interpretations thereof, unless the context requires otherwise;  
28.4 The word "including" means "including, without limitation" and does not limit the preceding words or terms; and  
28.5 All words used in this Agreement shall be construed to be of such gender, number or tense as circumstances require.
29. **Equal Employment Opportunity.** Each bidder agrees to comply with all applicable laws regarding equal employment opportunity and nondiscrimination.
30. **Authority to Bind.** The undersigned individual states that s/he has authority to bind Seller to this Agreement, that s/he has read and understands the terms of this Agreement, and that Seller agrees to be bound by this Agreement and its incorporated documents.



**Invitation For Bid IFB 20-822A  
Grapple Bulky Waste Truck  
Streets & Stormwater  
Issued: June 18, 2020**

**City of Tulsa,  
Oklahoma**  
Page 7 of 31

**FORM #2 (Page 4 of 4)  
PURCHASE AGREEMENT**

**IMPORTANT NOTE: This document must be signed by the proper person as set forth in Instructions, Terms and Conditions for Bidders, paragraph 4. FAILURE TO SUBMIT PROPERLY AUTHORIZED SIGNATURE MAY RESULT IN YOUR BID BEING REJECTED AS NONRESPONSIVE.**

IN WITNESS WHEREOF, this Agreement has been executed in multiple copies on the dates set forth below to be effective during the period recited above.

Seller Company Name: \_\_\_\_\_

**Sign Here ►** \_\_\_\_\_

ATTEST:

Printed Name: \_\_\_\_\_

Title: \_\_\_\_\_

\_\_\_\_\_  
Corporate Secretary

Date: \_\_\_\_\_

Company Name/Address [Please Print] \_\_\_\_\_ Address \_\_\_\_\_ City \_\_\_\_\_ State \_\_\_\_\_ Zip Code \_\_\_\_\_

( ) - ( ) - \_\_\_\_\_  
Telephone Number Fax Number Email Address

**CITY OF TULSA, OKLAHOMA,  
a municipal corporation,**

ATTEST:

By: \_\_\_\_\_  
Mayor

\_\_\_\_\_  
City Clerk

Date: \_\_\_\_\_

APPROVED:

\_\_\_\_\_  
Assistant City Attorney



**Tulsa**  
CITY OF  
A New Kind of Energy.

**Invitation For Bid IFB 20-822A  
Grapple Bulky Waste Truck  
Streets & Stormwater  
Issued: June 18, 2020**

**City of Tulsa,  
Oklahoma**  
Page 8 of 31

**FORM #3**

**INTEREST AFFIDAVIT**

STATE OF \_\_\_\_\_ )

)ss.

COUNTY OF \_\_\_\_\_ )

I, \_\_\_\_\_, of lawful age, being first duly sworn, state that I am the agent authorized by Seller to submit the attached Bid. Affiant further states that no officer or employee of the City of Tulsa either directly or indirectly owns a five percent (5%) interest or more in the Bidder's business or such a percentage that constitutes a controlling interest. Affiant further states that the following officers and/or employees of the City of Tulsa own an interest in the Bidder's business which is less than a controlling interest, either direct or indirect.

\_\_\_\_\_  
\_\_\_\_\_  
\_\_\_\_\_

By: \_\_\_\_\_  
Signature

Title: \_\_\_\_\_

Subscribed and sworn to before me this \_\_\_\_\_ day of \_\_\_\_\_, 20\_\_\_\_.

\_\_\_\_\_  
Notary Public

My Commission Expires: \_\_\_\_\_

Notary Commission Number: \_\_\_\_\_

County & State Where Notarized: \_\_\_\_\_

**The Affidavit must be signed by an authorized agent and notarized**





**FORM #4  
NON-COLLUSION AFFIDAVIT**

(Required by Oklahoma law, 74 O.S. §85.22-85.25)

STATE OF \_\_\_\_\_ )

)ss.

COUNTY OF \_\_\_\_\_ )

I, \_\_\_\_\_, of lawful age, being first duly sworn, state that:  
(Seller's Authorized Agent)

1. I am the authorized agent of Seller herein for the purposes of certifying facts pertaining to the existence of collusion between and among Bidders and municipal officials or employees, as well as facts pertaining to the giving or offering of things of value to government personnel in return for special consideration in the letting of any contract pursuant to the Bid to which this statement is attached.
2. I am fully aware of the facts and circumstances surrounding the making of Seller's Bid to which this statement is attached, and I have been personally and directly involved in the proceedings leading to the submission of such Bid; and
3. Neither the Seller nor anyone subject to the Seller's direction or control has been a party:
  - a. to any collusion among Bidders in restraint of freedom of competition by agreement to Bid at a fixed price or to refrain from Bidding,
  - b. to any collusion with any municipal official or employee as to quantity, quality, or price in the prospective contract, or as to any other terms of such prospective contract, nor
  - c. in any discussions between Bidders and any municipal official concerning exchange of money or other thing of value for special consideration in the letting of a contract.

By: \_\_\_\_\_  
Signature

Title: \_\_\_\_\_

Subscribed and sworn to before me this \_\_\_\_\_ day of \_\_\_\_\_, 20\_\_\_\_\_.

\_\_\_\_\_  
Notary Public

My Commission Expires: \_\_\_\_\_

Notary Commission Number: \_\_\_\_\_

County & State Where Notarized: \_\_\_\_\_

**The Affidavit must be signed by an authorized agent and notarized**



**CITY OF  
Tulsa**  
A New Kind of Energy.

**Invitation For Bid IFB 20-822A  
Grapple Bulky Waste Truck  
Streets & Stormwater  
Issued: June 18, 2020**

**City of Tulsa,  
Oklahoma**  
Page 10 of 31

**FORM #5**

**AFFIDAVIT OF CLAIMANT**

STATE OF \_\_\_\_\_ )

)ss.

COUNTY OF \_\_\_\_\_ )

The undersigned, of lawful age, being first duly sworn, on oath says that this contract is true and correct. Affiant further states that the work, services or materials will be completed or supplied in accordance with the contract, plans, specifications, orders or requests furnished the affiant. Affiant further states that (s)he has made no payment directly or indirectly of money or any other thing of value to any elected official, officer or employee of the City of Tulsa or any public trust of which the City is a beneficiary to obtain or procure the contract or purchase order.

By: \_\_\_\_\_  
Signature

Name: \_\_\_\_\_

Company: \_\_\_\_\_

Title: \_\_\_\_\_

Subscribed and sworn to before me this \_\_\_\_\_ day of \_\_\_\_\_, 20\_\_\_\_.

\_\_\_\_\_  
Notary Public

My commission expires: \_\_\_\_\_

My commission number: \_\_\_\_\_

**The Affidavit must be signed by an authorized agent and notarized**



**Tulsa**  
CITY OF  
A New Kind of Energy.

**Invitation For Bid IFB 20-822A  
Grapple Bulky Waste Truck  
Streets & Stormwater  
Issued: June 18, 2020**

**City of Tulsa,  
Oklahoma**  
Page 11 of 31

**FORM #6**

**ACKNOWLEDGMENT OF RECEIPT OF ADDENDA/AMENDMENTS**

I hereby acknowledge receipt of the following addenda or amendments, and understand that such addenda or amendments are incorporated into the Bid Packet and will become a part of any resulting contract.

List Date and Title/Number of all addenda or amendments: (Write "None" if applicable).

---



---



---



---



---



---

**Sign Here** ▶

Printed Name:

Title:

Date:



**Invitation For Bid IFB 20-822A  
Grapple Bulky Waste Truck  
Streets & Stormwater  
Issued: June 18, 2020**

**City of Tulsa,  
Oklahoma**  
Page 12 of 31

**INSTRUCTIONS, TERMS AND CONDITIONS FOR BIDDERS**

1. **PURCHASING AUTHORITY.** City issues this Invitation For Bid pursuant to Tulsa City Charter, Art. XII, §14 and Tulsa Revised Ordinances, Title 6, Ch. 4, the provisions of which are incorporated herein.
2. **DEFINITIONS.** The following terms have the following meanings when used in the documents comprising this Bid Packet.
  - A. **“Acceptance”** with respect to a Bid shall mean the City’s selection of a Bid, and award of a contract to the Bidder/Seller.
  - B. **“Acceptance”** with respect to delivery of Goods and/or Services provided under a Purchase Agreement shall mean City’s written acknowledgement that Seller has satisfactorily provided such Goods and/or Services as required.
  - C. **“Addenda” “Addendum” or “Amendment(s)”** shall mean a clarification, revision, addition, or deletion to this Invitation For Bid by City which shall become a part of the agreement between the parties.
  - D. **“Authorized Agent”** means an agent who is legally authorized to bind the Seller under the law of the State in which the Seller is legally organized. An Authorized Agent must sign all documents in the Bid Packet on behalf of the Seller. Under Oklahoma law, the Authorized Agent for each of the following types of entities is as stated below:
    - **Corporations** – the president, vice president, board chair or board vice chair can sign; others can sign if they have and provide the City with (i) a corporate resolution giving them authority to bind the Seller, and (ii) a recent corporate secretary’s certificate indicating the authority is still valid.
    - **General Partnerships** – any partner can sign to bind all partners.
    - **Limited Partnerships** – the general partner must sign.
    - **Individuals** – no additional authorization is required, but signatures must be witnessed and notarized.
    - **Sole Proprietorship** – the owner can sign. Any other person can sign if s/he provides a recent Power of Attorney, signed by the owner, authorizing him/her to bind the sole proprietorship.
    - **Limited Liability Company (LLC)** – The manager as named in the Operating Agreement can sign. Any person authorized by the Operating Agreement or a member can sign providing the person submits a copy of the authorization with a certificate of the members indicating the authorization is still valid.Entities organized in States other than Oklahoma must follow the law of the State in which they are organized.
  - E. **“Bid”** means the Seller’s offer to provide the requested Goods and/or Services set forth in Exhibit A and any additional materials or information the Seller chooses to submit to support the Bid.
  - F. **“Bidder”** means the legal entity which submits a Bid for consideration by City in accordance with the Invitation For Bid.
  - G. **“Bid Packet”** consists of the following documents (1) the Notice of Invitation for Bid, (2) the Summary Sheet, (3) Form #1, (4) Form #2, (5) Form #3, (6) Form #4, (7) Form #5, (8) Form #6, (9) the Instructions, Terms and Conditions for Bidders, (10) Special Requirements, (11) Technical Specifications, and (12) Exhibit A.
  - H. **“Bid Submission Date”** shall mean the last date by which the City will accept Bids for an Invitation For Bid.
  - I. **“City”** shall mean the City of Tulsa, Oklahoma.
  - J. **“Days”** shall mean calendar days unless specified otherwise.
  - K. **“Primary Seller”** shall mean the Seller whose Bid City selected as the principal supplier of the Goods and/or Services required under this Agreement.
  - L. **“Project Buyer”** shall mean the City’s employee assigned to serve as the contact person for Bidders/Sellers responding to Invitations For Bid or completing contracts herein.
  - M. **“Purchasing Division or Office”** shall mean the City of Tulsa’s Purchasing Division, located at 175 East 2<sup>nd</sup> Street, Suite 865, Tulsa, Oklahoma 74103
  - N. **“Secondary Seller”** shall mean the Seller whose Bid City selected as a back-up supplier in the event the Primary Seller is unable to provide all the Goods and/or Services required.



**Invitation For Bid IFB 20-822A  
Grapple Bulky Waste Truck  
Streets & Stormwater  
Issued: June 18, 2020**

**City of Tulsa,  
Oklahoma**  
Page 13 of 31

- O. **“Seller”** shall mean the Bidder whose Bid City selected and awarded a contract.
- P. **“You” or “Your”** shall mean the Bidder responding to this Invitation For Bid or the Seller whose Bid the City selected and awarded a contract.
- Q. **“Website”** shall mean the City of Tulsa’s website for the Purchasing Division: [www.cityoftulsapurchasing.org](http://www.cityoftulsapurchasing.org).
3. **QUESTIONS REGARDING INVITATION FOR BID.** Questions regarding any portion of this Invitation For Bid must be submitted in writing (sent by mail, fax or email) to the Project Buyer indicated on the Summary Sheet herein. You should submit questions as early as possible and preferably before the pre-Bid conference. Questions and concerns must be received no later than ten (10) days prior to the Bid Packet due date. Any oral responses to questions before the contract is awarded are not binding on City. At City’s discretion, any information or clarification made to you may be communicated to other Bidders that notified City of their intent to Bid if appropriate to ensure fairness in the process for all Bidders. You must not discuss questions regarding the Invitation For Bid with anyone other than the Project Buyer or other Purchasing Division staff or your Bid may be disqualified, any contract recommendation or Acceptance may be rescinded, or any contract may be terminated and delivered Goods returned at your expense and City refunded any payments made.
4. **ORAL STATEMENTS.** No oral statements by any person shall modify or otherwise affect the provisions of this Invitation For Bid and/or any contract resulting therefrom. All modifications, addenda or amendments must be made in writing by City’s Purchasing Division.
5. **EXAMINATION BY BIDDERS.** You must examine the specifications, drawings, schedules, special instructions and the documents in this Bid Packet prior to submitting any Bid. Failure to examine such documents and any errors made in the preparation of such Bid are at your own risk.
6. **ADDENDA OR AMENDMENTS TO INVITATIONS FOR BID.** City may addend or amend its Invitation For Bid at any time before the Bid Submission Date, and any such addenda or amendments shall become a part of this Agreement. City will attempt to send a notification (by fax or email) of any addenda or amendments to those Bidders who have responded to the City’s Project Buyer of their intent to respond to the Invitation For Bid. However, it is your responsibility to inquire about any addenda or amendments, which will be available from the City’s Purchasing Division and its website. You must acknowledge receipt of any addenda or amendments by signing and returning the Acknowledgment of Receipt of Addenda/Amendments form and attaching it to this Invitation For Bid with your Bid. City may reject any Bid that fails to acknowledge any addenda or amendments.
7. **SPECIFICATIONS/DESCRIPTIVE TERMS/SUBSTITUTIONS.** Unless the term “no substitute” is used, the City’s references to a brand name, manufacturer, make, or catalogue designation in describing an item in this Bid Packet does not restrict you to that brand or model, etc. The City may make such references to indicate the type, character, quality and/or performance equivalent of the item desired. However, you are required to furnish the exact item described in your Bid unless a proposed substitution is clearly noted and described in the Bid.
- The parties recognize that technology may change during the period Bids are solicited and subsequent contracts are performed. Therefore, City may at its option accept changes or substitutions to the specifications for Goods of equal or better capabilities at no additional cost to City. In the case of existing contracts, you shall give City 30 days advance notice in writing of any such proposed changes or substitutions. City shall determine whether such items are acceptable as well as any proposed substitute.
- All Goods shall be new unless otherwise so stated in the Bid. Any unsolicited alternate Bid, or any changes, insertions, or omissions to the terms and conditions, specifications, or any other requirements of this Bid, may be considered non-responsive and the Bid rejected.
8. **PRICES/DISCOUNTS.** Prices shall be stated in the units and quantity specified in the Bid Packet documents. In case of discrepancy in computing the Bid amount, you guarantee unit prices to be correct and such unit prices will govern. Prices shall include transportation, delivery, packing and container charges, prepaid by you to the destination specified in the Specifications. Discounts for prompt payment will not be considered in Bid evaluations, unless otherwise specified. However, offered discounts for prompt payment will be taken if payment is made within the discount period.
9. **DELIVERY.** All prices quoted shall be based on delivery F.O.B. Tulsa, Oklahoma or to any other points as may be designated in the Technical Specifications, with all charges prepaid by Seller to the actual point of delivery. Bids must state the number of days required for delivery under normal conditions.



**Invitation For Bid IFB 20-822A  
Grapple Bulky Waste Truck  
Streets & Stormwater  
Issued: June 18, 2020**

**City of Tulsa,  
Oklahoma**  
Page 14 of 31

10. **TAXES.** City is exempt from federal excise and state sales taxes and such taxes shall not be included in the Bid prices.
11. **BID SUBMISSION.** The Bid Packet forms must be prepared in the name of Bidder and properly executed by an Authorized Agent with full knowledge and acceptance of all provisions, in ink and notarized. Bids may not be changed or withdrawn after the deadline for submitting Bids (the "Bid Submission Date"). A Bid is an irrevocable offer and when accepted by City (as evidenced by City's execution of the Purchase Agreement) shall constitute a firm contract.
- A. BIDS MUST BE SUBMITTED ONLY ON THE BID PACKET FORMS AND SIGNED BY AN AUTHORIZED AGENT. THE ENTIRE BID PACKET MUST BE RETURNED AS RECEIVED WITH ALL FORMS COMPLETED. YOU MAY ATTACH, AFTER EXHIBIT A, ANY DOCUMENTS NECESSARY TO COMPLETELY AND ACCURATELY RESPOND TO THE REQUEST. BIDS MUST BE IN STRICT CONFORMANCE WITH ALL INSTRUCTIONS, FORMS, AND SPECIFICATIONS CONTAINED IN THIS BID PACKET.**
- B.** Sealed Bids may be either mailed or delivered, but must be received at:  
City of Tulsa – Office of City Clerk  
175 East 2<sup>nd</sup> Street, Suite 260  
Tulsa, Oklahoma 74103
- C.** Bids will be accepted at the above address from 8:00 a.m. to 5:00 p.m., Monday thru Friday except for City holidays. City is not responsible for the failure of Bids to be received by the City Clerk's Office prior to the due date and time.
- D.** Late Bids will be **rejected**. The Purchasing Agent, in his sole discretion, may make exceptions only for the following reasons:
1. City Hall closed for business for part or all of the day on the date the response was due;
  2. If the City deems it appropriate due to large-scale disruptions in the transportation industry that may have prevented delivery as required.
  3. If documented weather conditions caused the late delivery. You must provide documentation of such weather to the satisfaction of the Purchasing Agent.
- E.** **City will not accept faxed Bids**, nor will City accept Bids faxed to the City Clerk, Purchasing Division or Office, or any other City office or employee.
- F.** City is not responsible for any of your costs in preparing the Bid response, attending a pre-Bid conference, or any other costs you incur, regardless of whether the Bid is submitted, accepted or rejected.
- G.** All Bids must be securely sealed and plainly marked with the Bid Number, Bid Title, and Bid Opening Date on the lower left corner of the outside of the Bid envelope. Your name and address must also be clearly indicated on the envelope.
- H.** If submitting multiple options ("Option(s)") to the Invitation for Bid, each will be considered separately requiring each response to be complete and accurate. Each Option must be clearly marked as Option 1 of 3, Option 2 of 3, etc.
- I.** The number of copies you must submit is listed on the Summary Sheet in the front of the Bid Packet. However, at a minimum, there will be (1) an original, clearly labeled as such in 1" red letters on the Bid Packet cover page, and (2) a copy for City's Purchasing Division, clearly labeled as such in 1" red letters on the Bid Packet cover page. If binders are used, they must also be labeled.
- J.** Multiple boxes or envelopes are permissible, but must not weigh more than 50 pounds. Each box must be labeled as instructed herein and numbered (i.e., Box 1 of 3; Box 2 of 3). **The original must be in Box #1.**
- K.** The original and all copies (either paper or electronic) must be identical in all respects. Bids must be completed and submitted in ink or typewritten. Bids written in pencil will be rejected. Any corrections to the Bids must be initialed in ink.
12. **BID REJECTION OR WITHDRAWAL.**
- A. City may reject any or all Bids, in whole or in part.
  - B. **A Bid may be rejected if it contains additional terms, conditions, or agreements that modify the requirements of this Invitation For Bid or attempts to limit Bidder's liability to the City.**
  - C. A Bid may be rejected if Bidder is currently in default to City on any other contract or has an outstanding indebtedness of any kind to City.
  - D. City reserves the right to waive any formalities or minor irregularities, defects, or errors in Bids.
  - E. Bid withdrawal may only be accomplished by an Authorized Agent requesting the withdrawal in person at the City Clerk's office before the City's close of business on the Bid Submission Date.
13. **BID RESULTS.** A tabulation of Bids received will be made available on the City's Purchasing Division website generally within 5 working days after the Bid Opening Date. After a contract award is recommended to the Mayor, a copy of the Bid summary will be available in the City Clerk's Office. Bid results are not provided in response to telephone or email inquiries.
14. **PURCHASE ORDER.** In the event that the successful Bid is for an amount less than One Hundred Thousand Dollars (\$100,000), and it is determined by the City to be in the best interests of the City, the City, in its sole discretion, may issue a Purchase Order rather than execute the Purchase Agreement to purchase the Goods. If a Purchase Order is issued, however, the terms of the Bid Packet documents, including the Purchase Agreement, will govern the transaction and be enforceable by the City and Bidder/Seller.



**Invitation For Bid IFB 20-822A  
Grapple Bulky Waste Truck  
Streets & Stormwater  
Issued: June 18, 2020**

**City of Tulsa,  
Oklahoma**  
Page 15 of 31

15. **CONTRACT AWARD.** If a contract is awarded, it will be awarded to the Bidder that City determines is the lowest secure Bidder meeting specifications. Such Bid analysis will consider price and other factors, such as Bidder qualifications and financial ability to perform the contract, as well as operating costs, delivery time, maintenance requirements, performance data, history of contract relations with City, and guarantees of materials and equipment, as applicable. A complete list of the factors that are considered is set forth in Tulsa Revised Ordinances, Title 6, Ch. 4, §406E. Unless otherwise noted, City reserves the right to award a contract by item, one or more groups of items, or all the items in the Bid, whichever is in City's best interest.
16. **IRS FORM W-9.** If City selects your Bid and awards a contract to you, you will have ten (10) days from notification of the award to provide City with your complete IRS Form W-9.
17. **NOTICE TO PROCEED.** If City accepts your Bid and executes the Purchase Agreement, you shall not commence work until authorized to do so by the Purchasing Agent or his representative. Receipt of a Purchase Order from the City is notice to proceed.
18. **PAYMENTS.** Invoices should be e-mailed to City of Tulsa – Accounts Payable at:

[apinvoices@cityoftulsa.org](mailto:apinvoices@cityoftulsa.org)

Payment will be made Net 30 days after receipt of a properly submitted invoice or the City's Acceptance of the Goods and/or Services, whichever is later, unless City decides to take advantage of any prompt payment discount included in the Bid.

**THE REST OF THIS PAGE LEFT INTENTIONALLY BLANK**







**CITY OF  
Tulsa**  
A New Kind of Energy.

**Invitation For Bid IFB 20-822A  
Grapple Bulky Waste Truck  
Streets & Stormwater  
Issued: June 18, 2020**

**City of Tulsa,  
Oklahoma**  
Page 17 of 31

6. **References.** If the box is checked "Yes," References are required(3):

Yes:  **X**

No:

7. **Purchase Card:** Is the City of Tulsa Purchasing Card acceptable (This is a Visa):

Yes:

No:

**For each reference, the following information must be included: Company Name, Contact Name, Address, Phone Number, E-Mail Address, and the nature of their relationship with the Bidder.**

Company Name:	_____
Contact Name:	_____
Address:	_____
Phone Number:	_____
Email Address:	_____
Description of Services Provided:	_____
Company Name:	_____
Contact Name:	_____
Address:	_____
Phone Number:	_____
Email Address:	_____
Description of Services Provided:	_____
Company Name:	_____
Contact Name:	_____
Address:	_____
Phone Number:	_____
Email Address:	_____
Description of Services Provided:	_____

**THE REST OF THIS PAGE LEFT INTENTIONALLY BLANK**



**Invitation For Bid IFB 20-822A  
Grapple Bulky Waste Truck  
Streets & Stormwater  
Issued: June 18, 2020**

**City of Tulsa,  
Oklahoma**  
Page 18 of 31

**TECHNICAL SPECIFICATIONS**

**SCOPE:**

It is the intent during the agreement period, as nearly as possible, to purchase all the requirements for a grapple truck, bid from the firm(s) to which the agreement is awarded.

All vehicles bid shall be new and the latest production model. Brochures and/or specification literature clearly describing the unit(s) and verifying that the unit(s) meet or exceed the requirements of this specification should accompany each bid proposal. Warranty and delivery information should be provided with the bid proposal. Any Manufacturer's name and model called out in this IFB is intended to set the quality and design of equipment desired and is not meant to limit bidding on products of equal quality. Any exceptions to or deviations from the specifications set forth in the IFB should be clearly described in the bidder's proposal. During a standard warranty period or for any extended warranty no deductibles, upcharges, overtime, mileage, freight or charges for parts and service shall be charged to the City of Tulsa pertaining to warranty repairs.

For the purposes of bid evaluations, all options will be considered in the overall bid award.

**SPECIFICATIONS:**

In Section 2 (Bidder's Proposal Column); The bidder shall respond to each minimum requirement (section 1) in the space provided under Section 2 whenever asked to "describe", the description may include details such as size, capacities, dimensions, materials used in construction, etc. A full and complete description is required to reasonably evaluate the bid, so all pertinent information is required. When referring to attached literature as a means of not fully describing items, misinterpretations by the evaluator of the bid may occur and result in not having the bid awarded. Your ability to present the City with enough information to reasonably understand the item being bid and whether it meets the specifications stated relies on the written information provided.

You are requested to describe your proposal in the Bidders column, you may not respond in the space provided as to whether you meet the specifications by responding with terms as "yes", "Meets", "same as", "complies" or "similar" terms. If these terms are utilized, it may result in your bid being considered as Non-Compliant and being rejected.

You must include descriptive manufacturer's literature verifying the information you provided in the bidder's proposal section. Failure to provide such literature may result in your bid being considered as Non-Compliant, and possibly being rejected.

If your bid is an alternate approach and does not fully meet the specifications, completely describe your alternate approach.

The manufacturer shall warrant each vehicle and related parts to be of good material and workmanship and to promptly replace any part or parts which by reason of defective materials or workmanship shall fail under normal use, free of negligence or accident, for a minimum of one (1) year from the date of delivery, unless otherwise stated. In addition, if such failures take place outside the dealer's service area, which shall be defined as Tulsa city limits, the seller will be responsible for reimbursing the nearest manufacturer's authorized dealer for services rendered under this warranty.

The seller shall respond within 72 hours, of notification by the City of Tulsa, on when, where and how a warranty issue will be resolved. In the event there is no response within 72 hours, or if the response is not acceptable to the City of Tulsa; the City will provide or arrange for repairs. The seller shall be responsible for reimbursing the nearest manufacturer's authorized dealer in the city of Tulsa for services rendered under this warranty.

**The seller shall have the option to authorize the City of Tulsa to perform minor warranty replacement and repairs and then reimburse the City for its labor and parts utilized to enact the repair. The reimbursement for labor will be the same rate as that of the actual work performed. Standard warranty information is to be supplied with the bid.**



**Invitation For Bid IFB 20-822A  
Grapple Bulky Waste Truck  
Streets & Stormwater  
Issued: June 18, 2020**

**City of Tulsa,  
Oklahoma**  
Page 19 of 31

**DELIVERY REQUIREMENTS:**

Unless otherwise agreed to in writing; Seller shall transport the vehicles to and from the Seller's location for mounting of equipment and accessories with no additional charges to the City. Seller shall bear the cost of all transportation associated with warranty repairs. If Sellers location is outside of Tulsa County, Seller shall supply the name of the local factory authorized repair facility. The factory authorized warranty repair facility shall be contacted for verification prior to awarding the bid. This information shall be part of the bid evaluation process. Failure to comply will affect the award of bid.

Name: \_\_\_\_\_ Address: \_\_\_\_\_ Telephone: \_\_\_\_\_

The seller shall have the option to authorize the City of Tulsa to perform minor warranty replacement and repairs and then reimburse the city for its labor and parts utilized to perform the repair. Work performed by the City of Tulsa to address warranty repairs will be reimbursed by the Bidder. Reimbursement for labor will be the same as that charged by the Asset Management Department for unscheduled over-time. The reimbursement for parts will be at cost plus 25%. The labor rate for technicians assigned to Asset Management Department for fiscal year 2019-2020 is \$78.00 per hour during normal business hours and \$117.00 per hour for unscheduled over-time.

The Seller shall deliver all vehicles fully assembled and operational with all items such as mounting brackets, fluids such as oil and fuel, batteries, etc. installed upon delivery. No crated or non-operational equipment requiring assembly or adjustments of any kind shall be accepted. Seller will be required to operate the equipment and demonstrate all features and operational modes to the City of Tulsa personnel.

Absolutely no items over 500lbs. may be directly shipped to the City of Tulsa requiring the City personnel to unload from the shipping truck or trailer. The City of Tulsa carries no responsibility for any damages incurred during an unloading occurrence. The City of Tulsa does not have unloading docks or the proper equipment to assist in this area. All unloading shall be the responsibility of the seller and/or shipping entity.

**An MSO (Manufacturer's Statement of Origin) and an Oklahoma Application of title shall be provided at delivery. The City of Tulsa is required to license (tag) all vehicles and equipment.**

**TESTS AND ACCEPTABILITY OF MATERIAL:**

All items included in the bid are subject to a performance demonstration within 30 days of the bid date by the bidder(s) at the discretion of the City of Tulsa. A like item of the type bid that contains all the safety concerns, horsepower ratings, accessories, dimensions or other features as deemed appropriate by the City of Tulsa may be required to be demonstrated to the City of Tulsa personnel prior to award of the bid to establish if the item meets the requirements & specifications of the City of Tulsa. These demonstrations may be held in direct competition with other bidders whom bid the same items and equipment.

Section 1 Item 1	Specifications (Minimum)	Section 2 Bidders Proposal
Equipment	This specification is for a new current year model 33,000 lb. gv. Dual rear wheel, 2-door conventional chassis cab.	Describe: Make: _____ Model: _____ _____
Gross Vehicle Weight	33,000 lbs.	Describe: _____
	1. Style: 2-door conventional cab chassis 108-inch BBC approx. 168-inch CA approx. to	Describe: 1 _____ _____



**Invitation For Bid IFB 20-822A  
Grapple Bulky Waste Truck  
Streets & Stormwater  
Issued: June 18, 2020**

Cab	accommodate for the grapple body installation.	
	2. Seat(s): Air ride driver's seat, bench type companion seat with seatbelts for 3 people.	2
	3. Seat covering: Heavy duty vinyl.	3
	4. Sun visors: (1) LH. And (1) RH.	4
	5. Arm rests (1) LH. AND (1) RH.	5
	6. Interior lighting: Dome light with door activated switch.	6
	7. Windshield wipers: Electric 2-speed intermittent with dual washers.	7
	8. Mirrors: Exterior, remote controlled from the driver's seat, heated, approx. 7-inch X 16-inch with 8-inch diameter bolt on convex type mirrors mounted on each side.	8
	9. Front fender mounted 7-inch convex mirrors, both sides.	9
	10. Air conditioning: Factory installed through-dash type with electronic diagnostic and protection system.	10
	11. Gauges: Full gauge package with factory audible alarms and lights.	11
	A. Transmission Temp Gauge	A
	B. Tachometer	B
	C. Oil pressure gauge	C
	D. Air pressure gauge	D
	E. Speedometer	E
	F. Hour meter mounted inside the cab	F
	G. Coolant Temp Gauge	G
	12. Additional instructions: Include the following:	12
	A. 12 Volt power point	A
B. Full head liner.	B	
C. Full rubber floor mat	C	
D. Factory installed AM/FM weather band radio	D	
E. High heat warning light for the transmission.	E	
F. Factory tinted glass throughout	F	
G. Tilting hood	G	
H. Dual air horns	H	
I. Interior grab handles, and exterior grab handles to aid in easier entry into cab. LH & RH.	I	



**Invitation For Bid IFB 20-822A  
Grapple Bulky Waste Truck  
Streets & Stormwater  
Issued: June 18, 2020**

**City of Tulsa,  
Oklahoma**  
Page 21 of 31

Engine	<ol style="list-style-type: none"> <li>1. Diesel power, Mfg., model &amp; Type. Cummins preferred.</li> <li>2. Displacement: 8.8L minimum.</li> <li>3. Horsepower: 350 hp minimum.</li> <li>4. Torque: 950 Ft Lb. at 1400 rpm minimum.</li> <li>5. Emissions: DPF/SCR/DEF no EGR only engine accepted</li> <li>6. Air cleaner: Dry type dual replaceable elements.</li> <li>7. Oil filter: Full flow, spin-on type.</li> <li>8. Fuel filter: In-line type</li> <li>9. Block heater: 110 Volt 1250 Watt to be included. Mounted under driver's door.</li> <li>10. Water separator: In-line, Racor or equal with heater, warning light and drain valve.</li> <li>11. Exhaust system: Horizontally mounted as to not interfere with the body installation or operation of the grapple unit.</li> <li>12. Electronic engine over-speed protection for the PTO.</li> <li>13. Engine shut-down and de rate system for low oil pressure, temperature and coolant level.</li> <li>14. Emissions: Must meet current EPA standards.</li> </ol>	<p><u>Describe:</u></p> <p>1 MFG: _____</p> <p>MODEL: _____</p> <p>2 Displacement: _____</p> <p>3 _____</p> <p>4 _____</p> <p>5 _____</p> <p>6 _____</p> <p>7 _____</p> <p>8 _____</p> <p>9 _____</p> <p>10 _____</p> <p>11 _____</p> <p>12 _____</p> <p>13 _____</p> <p>14 _____</p> <p>15 _____</p>
Transmission	<ol style="list-style-type: none"> <li>1. Type: Automatic.</li> <li>2. Speed: Six (6) Speeds with overdrive.</li> <li>3. Manufacturer: Allison.</li> <li>4. Model no: 4000 rds.</li> <li>5. Fluid cooler: To be included</li> <li>6. Relocate transmission ECU in cab.</li> <li>7. PTO mounted on transmission coupled directly to the Hydraulic pump. PTO shall be "hot shift" type automatically disengaging when vehicle is placed in gear, reengages when shifted into neutral. Electronic dash mounted controls with engagement light. No levers or cables. Overspeed protection required.</li> </ol>	<p><u>Describe:</u></p> <p>1 _____</p> <p>2 _____</p> <p>3 _____</p> <p>4 _____</p> <p>5 _____</p> <p>6 _____</p> <p>7 _____</p> <p>_____</p> <p>_____</p> <p>_____</p> <p>_____</p> <p>_____</p>



**Invitation For Bid IFB 20-822A  
Grapple Bulky Waste Truck  
Streets & Stormwater  
Issued: June 18, 2020**

**City of Tulsa,  
Oklahoma**  
Page 22 of 31

Cooling System	<ol style="list-style-type: none"> <li>1. Radiator: Largest capacity available from the manufacturer.</li> <li>2. Coolant recovery system: To be included.</li> <li>3. Extended life antifreeze.</li> </ol>	<u>Describe:</u> 1 _____ _____ 2 _____ _____ 3 _____ _____
Electrical System	<ol style="list-style-type: none"> <li>1. 12 Volt system</li> <li>2. Battery(s):               <ol style="list-style-type: none"> <li>A. Quantity: As required.</li> <li>B. CCA. Total: 1800 CCA.</li> </ol> </li> <li>3. Alternator amp output: Minimum 160.Amp, Brushless.</li> <li>4. All Lights to be LED, headlights to be Halogen.</li> <li>5. Include all lights and reflectors to comply with all Federal and Oklahoma State laws for 24-hour operation on all highways.</li> <li>6. Must provide manufacturers separate electronic junction box for additional wiring of body attachments.</li> <li>7. 12-volt circuit breakers in lieu of fuses where available.</li> <li>8. Battery Tender with plug in mounted below driver's door. Kussmaul, Auto charge 1000 preferred.</li> <li>9. Battery heater pad to be installed and wired to the same plug in for the battery tender. Heater pad to be 120 Volt, 200 Watts with preset heater to maintain the batteries at 80 degrees Fahrenheit.</li> </ol>	<u>Describe:</u> 1 _____ 2 _____ A _____ B _____ 3 _____ _____ 4 _____ 5 _____ _____ 6 _____ _____ 7 _____ _____ 8 _____ _____ 9 _____ _____ _____
Brake System	<ol style="list-style-type: none"> <li>1. Bendix 4S/4M ABS brake system.</li> <li>2. Service brake: Dual air system.</li> <li>3. Parking brake: MGM spring, 30/30 brake chambers.</li> <li>4. Air compressor: 15.8 cfm Bendix 921 or equivalent, with DV-2 automatic air tank drain(s).</li> <li>5. Automatic slack adjusters with travel indicators</li> </ol>	<u>Describe:</u> 1 _____ 2 _____ 3 _____ _____ 4 _____ _____ 5 _____ _____
Steering	Type: Power steering with tilting and telescoping steering column.	<u>Describe:</u> _____ _____



**Invitation For Bid IFB 20-822A  
Grapple Bulky Waste Truck  
Streets & Stormwater  
Issued: June 18, 2020**

**City of Tulsa,  
Oklahoma**  
Page 23 of 31

<p align="center">Suspension</p>	<ol style="list-style-type: none"> <li>1. Front axle: 12,000 lbs.</li> <li>2. Front springs: 12,000 lbs.</li> <li>3. Rear axle: 21,000 LBS. capacity,</li> <li>4. Rear springs: 23,500 lbs. capacity</li> <li>5. Rear axle speed: Single</li> <li>6. Rear axle manufacturer and stock number: The manufacturer's standard.</li> <li>7. Stabilizer bar(s): Mfg. std.</li> <li>8. Shocks: Heavy duty front and rear.</li> <li>9. Wheel seals: Oil type on all axles.</li> </ol>	<p><u>Describe:</u></p> <p>1 _____</p> <p>2 _____</p> <p>3 _____</p> <p>4 _____</p> <p>5 _____</p> <p>6 _____</p> <p>7 _____</p> <p>8 _____</p> <p>9 _____</p>
<p align="center">Frame</p>	<p><b>The City of Tulsa will not accept any frame lengthening modifications</b></p> <ol style="list-style-type: none"> <li>1. Section Modulus: 14.8</li> <li>2. Yield strength: 120,000 psi.</li> <li>3. RBM: Min. 1,700,000 lbs.</li> </ol>	<p><u>Describe:</u></p> <p>1 _____</p> <p>2 _____</p> <p>3 _____</p>
<p align="center">Wheelbase</p>	<p>As required for mounting the body and accessories. Approx. 168 inches CA.</p>	<p><u>Describe:</u></p> <p>_____</p> <p>_____</p>
<p align="center">Wheels</p>	<ol style="list-style-type: none"> <li>1. Front size: 22.5 X 8.25</li> <li>2. Front type: 10-hole, hub piloted.</li> <li>3. Rear size: 22.5 X 8.25</li> <li>4. Rear type: 10-hole, hub piloted.</li> </ol>	<p><u>Describe:</u></p> <p>1 _____</p> <p>2 _____</p> <p>3 _____</p> <p>4 _____</p>
<p align="center">Tires</p>	<ol style="list-style-type: none"> <li>1. Front size: 11R22.5 14-ply.</li> <li>2. Front tread design: Highway, radial.</li> <li>3. Rear size: 11R22.5 14-ply.</li> <li>4. Rear tread design: Mud and snow, radial.</li> <li>5. Spare(s): Two (2) 10-hole, hub piloted spare tires and wheels mounted: Radial highway tread front and radial mud and snow rear.</li> </ol>	<p><u>Describe:</u></p> <p>1 _____</p> <p>2 _____</p> <p>3 _____</p> <p>4 _____</p> <p>5 _____</p> <p>_____</p>
<p align="center">Fuel Tank</p>	<ol style="list-style-type: none"> <li>1. Quantity: One.</li> <li>2. Capacity: 50 Gallons.</li> <li>3. Type and construction: Aluminum.</li> <li>4. Note: Specify if fuel tank, exhaust, air dryer etc. are mounted in such a way as to protrude behind the cab or rearward of cab on frame.</li> </ol>	<p><u>Describe:</u></p> <p>1 _____</p> <p>2 _____</p> <p>3 _____</p> <p>4 _____</p> <p>_____</p> <p>_____</p>



**Invitation For Bid IFB 20-822A  
Grapple Bulky Waste Truck  
Streets & Stormwater  
Issued: June 18, 2020**

**City of Tulsa,  
Oklahoma**  
Page 24 of 31

Undercoating	Chassis and dump body to be full undercoated as per manufacturers standard.	<u>Describe:</u> <hr/> <hr/>
Paint	Manufacturer's standard White	<u>Describe:</u> <hr/>
Bumpers	1. Front: Manufacturer's standard. 2. Rear: Must be ICC compliant for rear underside protection. 3. Hitch: Not required. 4. Additional Instructions: Include two (2) front frame mounted tow hooks.	<u>Describe:</u> 1. <hr/> 2. <hr/> 3. <hr/> 4. <hr/>
Additional	Additional accessories and/or instructions: 1. Wheelbase and cab to axle dimensions for mounting the bodies being bid. 108 inches BBC approx. 168 inches CA approx.	<u>Describe:</u> 1. <hr/> <hr/>
Manuals	Supply 2 each: 1. CD ROM Parts manual 2. CD ROM Service manual (If parts and service manuals are free and available to the City of Tulsa on the Internet, please state and furnish the web site)	<u>Describe:</u> 1. <hr/> 2. <hr/> <hr/>
Truck Warranty	Extended warranty for five (5) years or 150,000 miles on: (Provide a complete list of what is covered) 1. Engine. And engine electronics Including turbo and injectors. 2. Exhaust After-treatment. 3. Engine Electronics 4. Transmission  State nearest authorized repair station for entire truck, including the engine and transmission. The City of Tulsa shall expect the seller to provide all warranty for the entire cab chassis and all components installed by the manufacturer or the vendor.	<u>Describe:</u> <hr/> <hr/> <hr/> 1. <hr/> 2. <hr/> 3. <hr/> 4. <hr/> <hr/> <hr/> <hr/> <hr/> <hr/>





**Invitation For Bid IFB 20-822A  
Grapple Bulky Waste Truck  
Streets & Stormwater  
Issued: June 18, 2020**

**City of Tulsa,  
Oklahoma**  
Page 25 of 31

Accessory Switches	Six switches within easy access to the driver, mounted in dash located in the cab to accommodate body and accessory connections as needed.	<u>Describe:</u> <hr/> <hr/> <hr/> <hr/>
--------------------	--	---

**GRAPPLE/CRANE AND BODY SPECIFICATIONS:**

Grapple/Crane Pedestal Assembly	Open A-frame type. Peterson TL-3 Lightning Loader or equivalent. Total height not to exceed 7 (seven) feet from mounting plate to top of pedestal/main boom connection point swing post, single piece high strength solid steel (ASTM 4140) turning in (ASTM-D4020-81) cast nylon bearings. Welded spindle/head assembly to be stress relieved prior to installation.	<u>Describe:</u> <hr/> <hr/> <hr/> <hr/> <hr/> <hr/> <hr/>
Boom	Boom rotation to be accomplished by a direct drive 270-degree planetary gear box with Geroter piston hydraulic rotary actuator. Maximum torque rate, 250,000 in. lbs. minimum. This enclosed gearbox must be 100% oil bath which eliminates the lubrication labor and metal-metal wear found in open, exposed pinion and bull gear design.	<u>Describe:</u> <hr/> <hr/> <hr/> <hr/> <hr/> <hr/> <hr/>





**Invitation For Bid IFB 20-822A  
Grapple Bulky Waste Truck  
Streets & Stormwater  
Issued: June 18, 2020**

	<p>4. Safety locking valves – installed on both boom and outrigger cylinders. Prevents leak down or collapse due to hydraulic line rupture.</p> <p>5. Pump – single commercial Inter tech P-20 or acceptable equal.</p> <p>6. Conductors – steel tubing and high tensile wire braided hoses, 4000 psi and 16,000 psi, minimum burst</p> <p>7. All hydraulic fittings to be JIC.</p>	<p>4 _____</p> <p>_____</p> <p>_____</p> <p>5 _____</p> <p>_____</p> <p>_____</p> <p>6 _____</p> <p>_____</p> <p>_____</p> <p>7 _____</p> <p>_____</p> <p>_____</p>
<p>Operator Controls and Platform</p>	<p>Engine programmed for proper RPM level, actuated by heavy-duty toggle switch at operator's station.</p> <p>Control platform behind cab at truck frame height, grip strut serrated steel walk platform. Single bank of control valves mounted at mid-point of loader.</p> <p>Control handles accessible from operator platform, either side of truck. Control handle pattern identical on both side of truck.</p>	<p><u>Describe:</u></p> <p>_____</p> <p>_____</p> <p>_____</p> <p>_____</p> <p>_____</p> <p>_____</p> <p>_____</p> <p>_____</p>
<p>Outrigger stabilizers</p>	<p>Outriggers to be constructed with hydraulically powered telescoping rectangular tubing to preventing side loading and bending of cylinder shafts. Outriggers to be equipped with large steel pads to minimize damage to street. Outriggers must telescope out and down to reach a horizontal distance of approx. 11-feet 8-inches between out edges. Outward stabilizer movement of each stabilizer to be powered by a hydraulic cylinder with a bore of approx. 2-inches and a stroke of approx. 20-inches. The housing that accomplishes this outward movement must be separated by cast nylon bushings on all four sides to prevent metal-to-metal wear and to allow a greater area for grease. Downward movement to be powered by two hydraulic cylinders with a bore of approx. 3-inches and a stroke of approx. 22-inches. These cylinders must be fully enclosed for protection.</p>	<p><u>Describe:</u></p> <p>_____</p> <p>_____</p> <p>_____</p> <p>_____</p> <p>_____</p> <p>_____</p> <p>_____</p> <p>_____</p> <p>_____</p> <p>_____</p> <p>_____</p> <p>_____</p> <p>_____</p> <p>_____</p> <p>_____</p>



**Invitation For Bid IFB 20-822A  
Grapple Bulky Waste Truck  
Streets & Stormwater  
Issued: June 18, 2020**

**City of Tulsa,  
Oklahoma**  
Page 28 of 31

<p align="center">Attachments</p>	<p>Clam shell type municipal trash bucket with continuous rotation bucket motor. Bucket dimensions: approx. 4-feet long, opening width of approx. 5-feet. Bucket actuated by a single double – acting cylinder. Bucket must be high impact tempered steel. Hoses below bucket motor are not permitted.</p>	<p><u>Describe:</u></p> <hr/> <hr/> <hr/> <hr/> <hr/> <hr/> <hr/> <hr/>
<p align="center">Painting</p>	<p>The crane shall be primed and painted white to match cab and bed. One coat primer and two coats high grade enamel.</p>	<p><u>Describe:</u></p> <hr/> <hr/> <hr/> <hr/>
<p align="center">Grapple/Crane Operations, Maintenance and Warranty</p>	<p>Warranty shall be 3 years parts and labor, on the grapple and dump body. Proper operating instructions; parts list and maintenance manuals shall be furnished in duplicate.</p>	<p><u>Describe:</u></p> <hr/> <hr/> <hr/> <hr/>
<p align="center">Dump Body with Hydraulic Hoist</p>	<p>Body – 24 cubic yards, 18-foot long, 91-inches wide, sidewall height is 42-inches at the front portion angling to 60-inches at the rear. Floor 3/16-inch thick. Sides, 10-gauge smooth sheet steel.</p>	<p><u>Describe:</u></p> <hr/> <hr/> <hr/> <hr/>
<p align="center">Side Post/Cross-sills and Longsills</p>	<p>Channel construction to provide structural support to prevent flare out on sides.</p>	<p><u>Describe:</u></p> <hr/> <hr/> <hr/> <hr/>
<p align="center">Rear Door</p>	<p>Barn door type capable of swinging completely around to be secured on side of container. Positive lock/latch to be included that will hold rear door open while being dumped. Doors to be fabricated from same material as side with an outside frame with one center post. Red and Yellow conspicuity tape to be installed on the rear doors. 6-inches wide reflective tape to cover both doors, installed at 45-degree angle meeting in the middle.</p>	<p><u>Describe:</u></p> <hr/> <hr/> <hr/> <hr/> <hr/> <hr/> <hr/> <hr/> <hr/> <hr/>
<p align="center">Hydraulic Hoist</p>	<p>Scissor type, dual cylinder with 16-ton capacity. Hoist to raise body minimum of 46-degree dump angle without touching the ground.</p>	<p><u>Describe:</u></p> <hr/> <hr/> <hr/> <hr/>



**Invitation For Bid IFB 20-822A  
Grapple Bulky Waste Truck  
Streets & Stormwater  
Issued: June 18, 2020**

**City of Tulsa,  
Oklahoma**  
Page 29 of 31

Light Reflectors	Meet federal lighting standards for highway travel. Red/white conspicuity tape to run down both sides of the bed from front to back.	Describe: _____ _____ _____
Tarp System	Electrical powered tarp system with hole to fit bucket. Electric Roll Rite Tarp system with arm assistance or acceptable equal.	Describe: _____ _____ _____
Paint	White to match loader and cab. One coat primer and two coats high grade enamel inside requires only one coat primer and one coat enamel.	Describe: _____ _____ _____
Grapple and Bed Warranty	Manufacturer's standard warranty for a minimum of 36 months.	Describe: _____ _____ _____

Bulky Waste Grapple Truck, Streets & Stormwater, FY 19-20

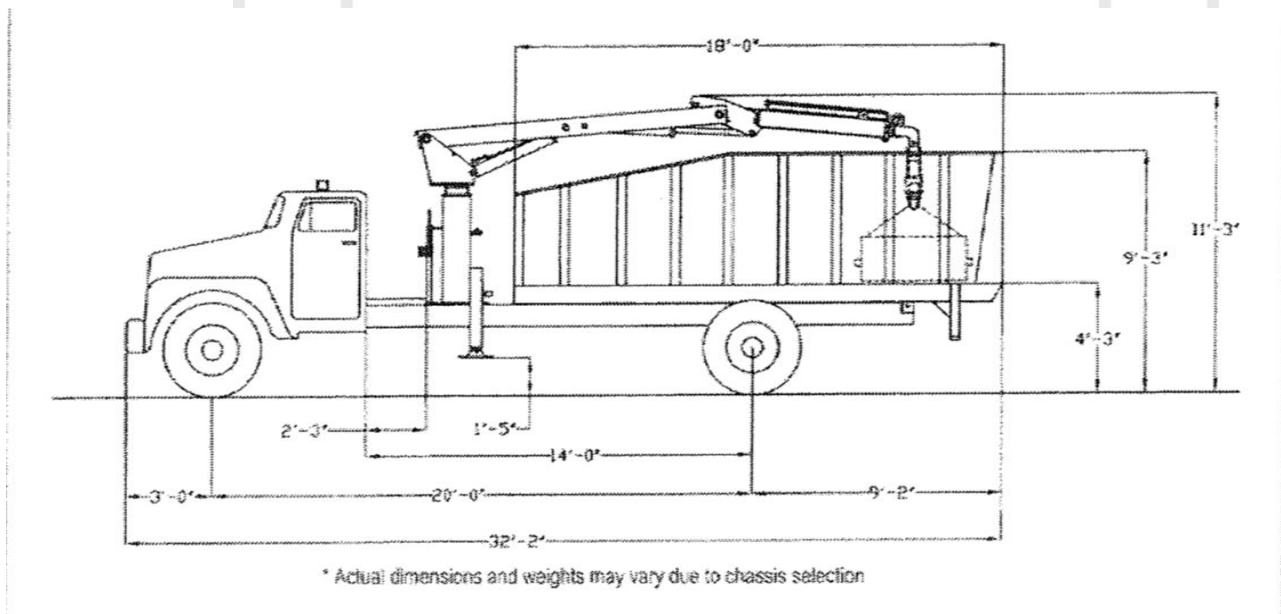

<p><b>These costs may be considered in the overall bid award:</b></p>	<p align="center"><b>Bidder's Response:</b> <b>(May attach additional pages for this section.)</b></p>
<p>Due to possible delays in equipment and body add-ons, warranty start dates shall be when the City of Tulsa can get the vehicle into service operation. In-service dates are estimated to be no more than 60 days after delivery of vehicle to the City of Tulsa inventory section. Please indicate whether you can provide this extension of warranty and if so, how many days after delivery date to the city will you extend the</p>	<p>Describe:</p>



**Tulsa**  
A New Kind of Energy.

**Invitation For Bid IFB 20-822A  
Grapple Bulky Waste Truck  
Streets & Stormwater  
Issued: June 18, 2020**

**City of Tulsa,  
Oklahoma**  
Page 30 of 31

warranty? Please provide any additional details for responding to this section.

**SPECIFICATION ATTACHMENT CHECKLIST**

In addition to the items required for the bid as listed on the checklist at the beginning of the bid package, use the following checklist to ensure you have provided all required attachments based on the technical specifications. Bids submitted by the Seller must include the following attachments, as required by the technical specifications:

- \_\_\_\_\_ Brochures and/or specification literature clearly describing the unit(s) and verifying that the unit(s) meet or exceed the requirements of this specification
- \_\_\_\_\_ Warranty documentation should be provided with the bid proposal

**THE REST OF THIS PAGE LEFT INTENTIONALLY BLANK**



**CITY OF  
Tulsa**  
A New Kind of Energy.

**Invitation For Bid IFB 20-822A  
Grapple Bulky Waste Truck  
Streets & Stormwater  
Issued: June 18, 2020**

**City of Tulsa,  
Oklahoma**  
Page 31 of 31

**EXHIBIT A  
BID FORM INCLUDING DELIVERY AND PRICING**

**1. Delivery.** If your Bid is accepted and a contract is executed, state the number of days you need to deliver the Goods and/or to begin providing Services:

\_\_\_\_\_

You must be able to deliver the Goods and/or Services as specified in your Bid. Failure to do so may result in City terminating your agreement or canceling the Purchase Order, pursuing collection under any performance bond, as well as seeking any other damages to which it may be entitled in law or in equity.

**2. Pricing**

**(ESTIMATED QUANTITIES FOR EVALUATION PURPOSES ONLY)**

Item	Description	Estimate Annual QTY	Unit Cost	Extended Cost
1	Bulky Waste Grapple Truck	1 or more	\$	\$
<b>TOTAL COST NOT TO EXCEED:</b> <b>(All costs must be included or your Bid will be disqualified)</b>			\$ _____	

Bidder's Company Name \_\_\_\_\_

**Authorized Signature Here** ► \_\_\_\_\_

Printed Name: \_\_\_\_\_

**RETURN THIS ENTIRE BID PACKET**