

PATH NAME: /E1/PARTS/STD/DGN/STDS/552-41010IN-DET-CK.DGN RMD 10/12/2021

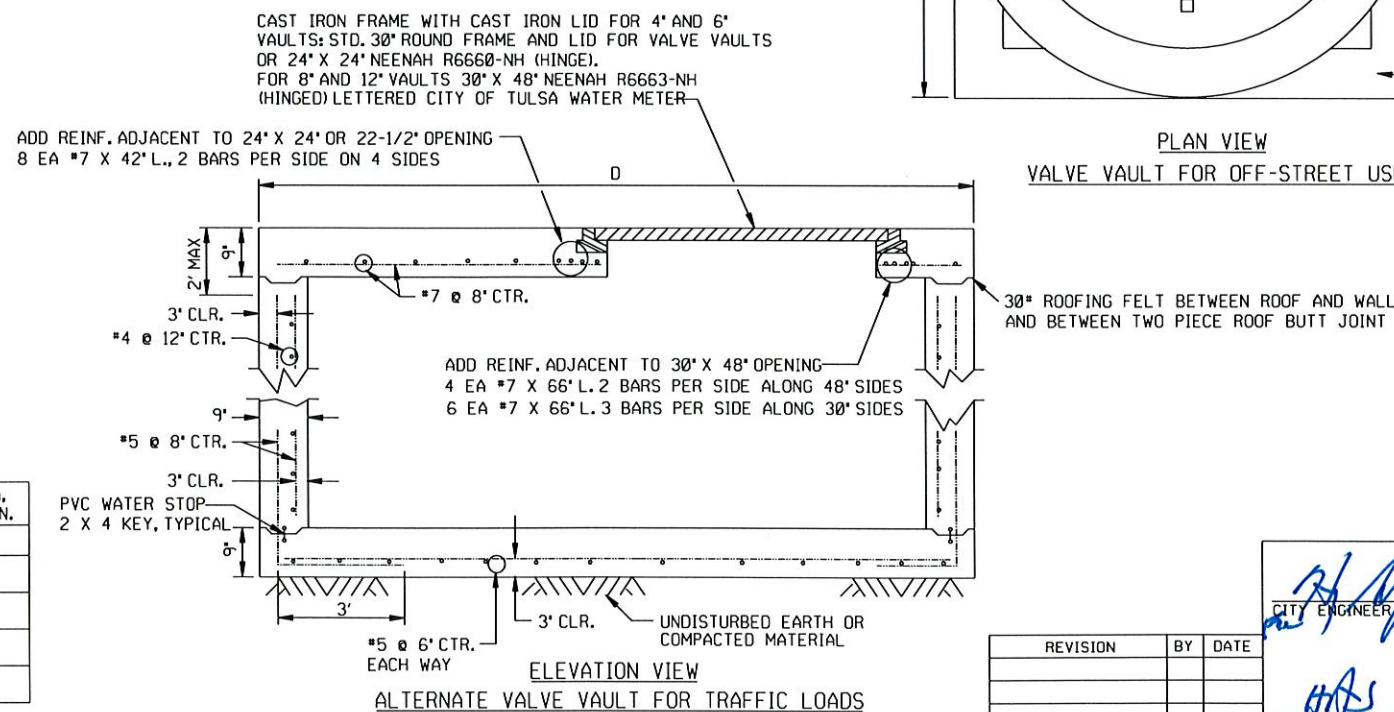
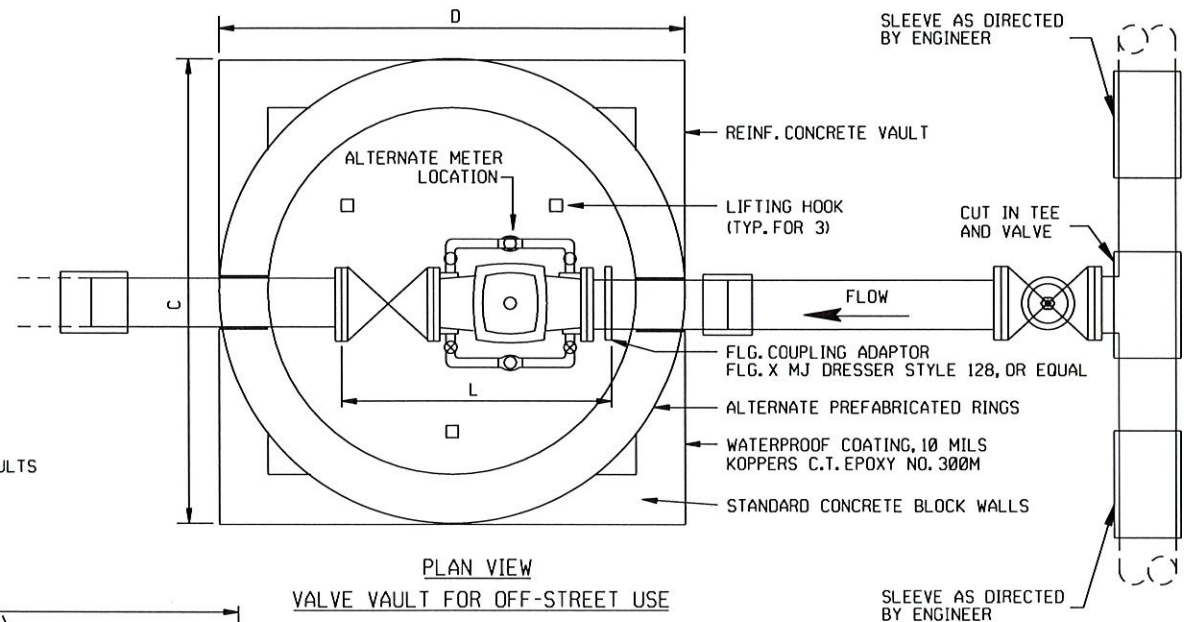
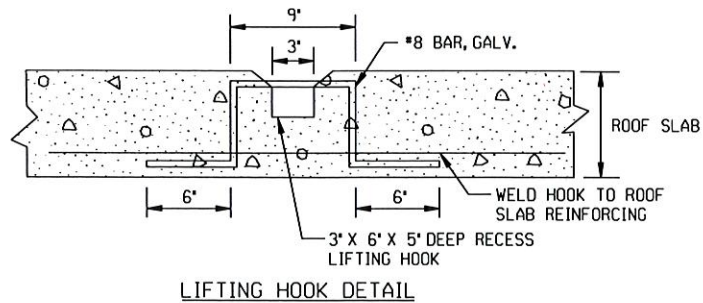
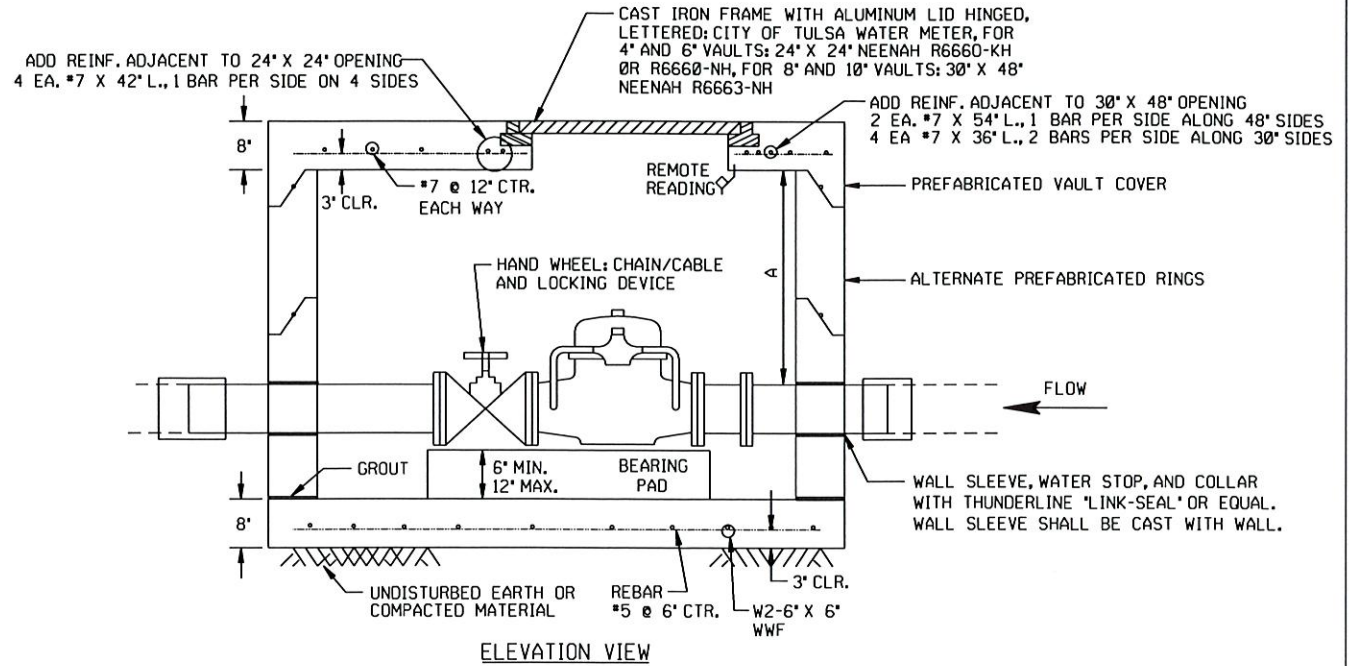
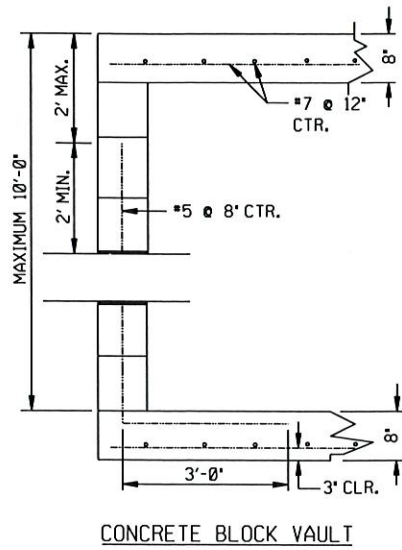
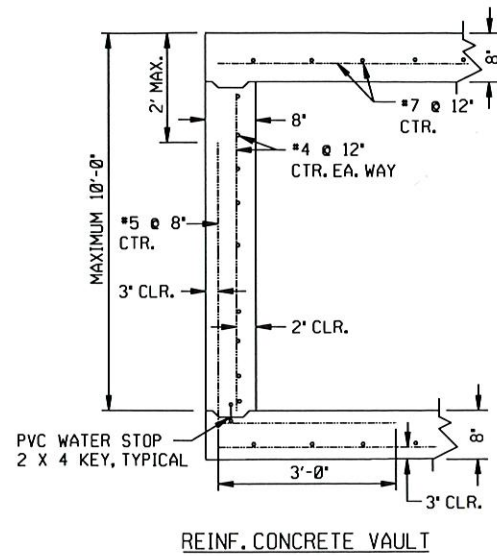

**NOTE:**

- CONTRACTOR SHALL FURNISH FITTINGS COMPATIBLE WITH THE TYPE OF PIPE FURNISHED.
- PRECAST CONCRETE VAULT SECTIONS SHALL CONFORM TO ANSI/ASTM C478.
- NOTICE SHALL BE GIVEN TO THE ENGINEERING SERVICES DEPARTMENT 48 HOURS IN ADVANCE SO THAT A REPRESENTATIVE OF THE DEPARTMENT MAY WITNESS THE POURING OF THE VAULT AND INSPECT THE MATERIALS. A REPORT SHALL BE FURNISHED ON THE 7 DAY AND 28 DAY STRENGTH OF THE CONCRETE WHICH SHALL BE AT LEAST 4000 PSI. REINFORCING STEEL SHALL BE GR. 60. BOLTS AND NUTS SHALL CONFORM TO ASTM A-307 GR. B, AND ASTM A-563 GR. A, RESPECTIVELY. STRUCTURAL STEEL SHALL BE ASTM A-36.
- WHERE RESTRAINED JOINTS ARE REQUIRED, THEY SHALL BE EBAA MEGALUG SERIES 1100 OR EQUAL.
- DOUBLE CHECK DETECTOR ASSEMBLY CONSISTS OF TWO SPRING LOADED ASSEMBLED IN A SHOP ENVIRONMENT APPROVED BY A REPRESENTATIVE OF TULSA ENGINEERING SERVICES DEPARTMENT METER AND FITTINGS SHALL BE DELIVERED TO THE JOB SITE WITH THE VALVES CLOSED IN ORDER TO PROTECT THE METER AND STRAINER.
- USE DUCTILE IRON PIPING AND DI/CI FITTINGS FROM THE MAIN LINE TAPPING SLEEVE TO DOWNSTREAM FROM THE METER CHECK VALVE AT THE CONNECTING SLEEVE. PIPE SHALL BE WRAPPED WITH POLYETHYLENE FILM AND TAPED.
- DRAWINGS NOT TO SCALE.

LINE AND DET. CHECK SIZE	REINF. CONCRETE OR CONCRETE BLK. MANHOLE		ALTERNATE PREFAB. RING MANHOLE		ALTERNATE TRAFFIC WAY MANHOLE		L TOTAL LAYING LENGTH	DIM. A, FT. MIN.
	C	D	INSIDE DIA.	WALL THICKNESS	C	D		
4'	5'	5'	5'	6"	5'	5'	34-1/4'	3'
6'	5'	5'	5'	6"	5'	5'	42-1/2'	3'
8'	5'	6'	6'	7"	6'	6'	47-5/8'	4'
10'	5'	8'	8'	9"	8'	8'	58-3/4'	5'

REVISION	BY	DATE

CITY OF TULSA, OKLAHOMA  
ENGINEERING SERVICES DEPARTMENT

4"-10" DETECTOR CHECK ASSEMBLY AND VAULT

DATE: OCTOBER 2021

STD. 552