

**TYPICAL MOUNTING DETAILS FOR PEDESTAL MOUNTED SLIP FITTER SIGNAL**

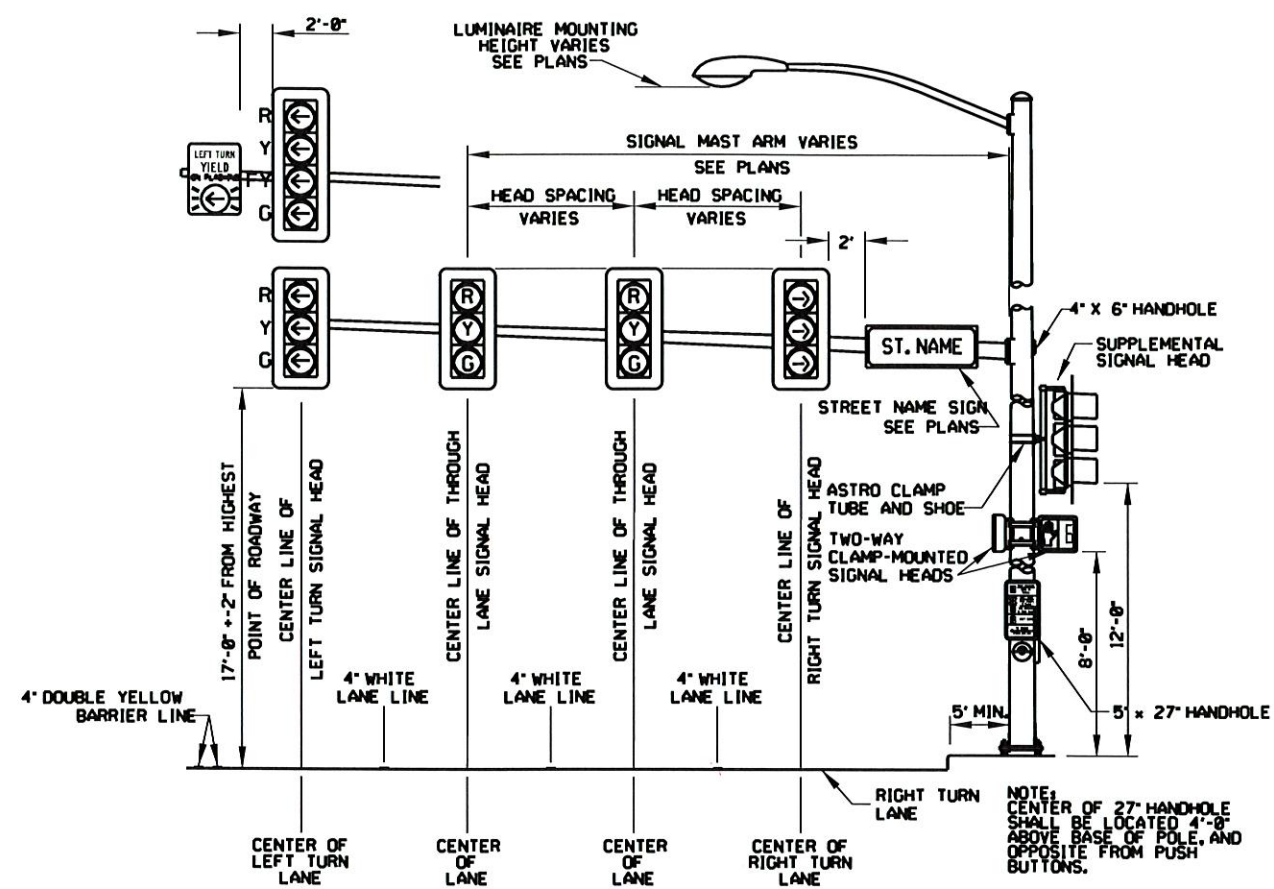

**TYPICAL SIGNAL EQUIPMENT PLACEMENT WITH PROTECTED ONLY HEADS**

**NOTE:**

1. PULL BOX LOCATIONS SHALL BE OUTSIDE OF WHEELCHAIR RAMP AND WHEEL DRAG PATH.
2. SIGNAL HEAD, PEDESTRIAN HEAD, AND PEDESTRIAN PUSH BUTTON PLACEMENT TO BE APPROVED BY THE TRAFFIC ENGINEER PRIOR TO INSTALLATION.
3. PUSH BUTTONS SHALL MEET MUTCD AND ADA REQUIREMENTS AND SHALL BE LOCATED WITHIN 18 INCHES OF A LEVEL, ALL-WEATHER SURFACE, AND NO CLOSER THAN 38 INCHES NOR MORE THAN 18 FEET FROM THE FACE OF CURB AT RAMP.

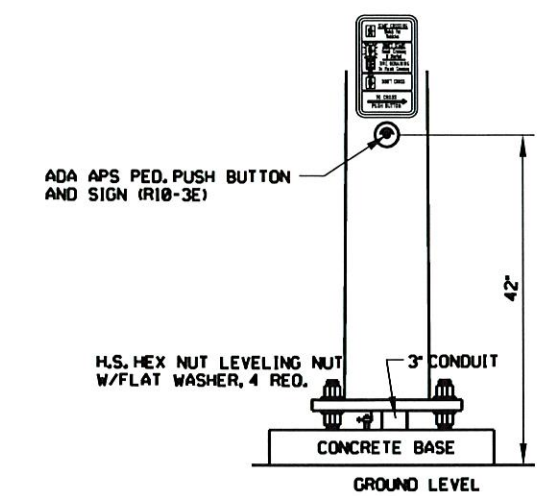

**TYPICAL MOUNTING DETAILS FOR PUSH BUTTONS AT MAST ARM POLE**

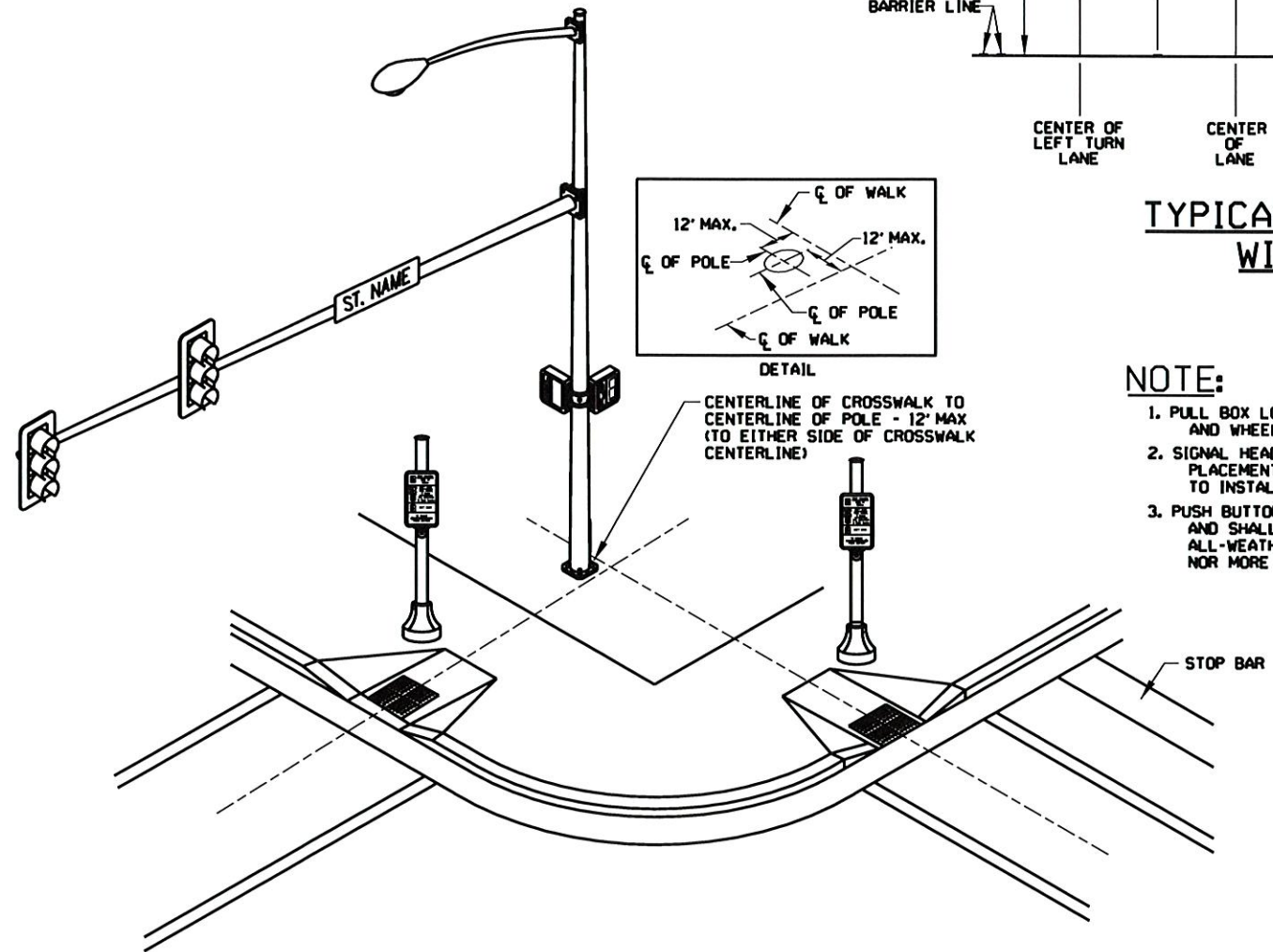

**TYPICAL SIGNAL POLE PLACEMENT FOR PEDESTRIAN CROSSWALKS**

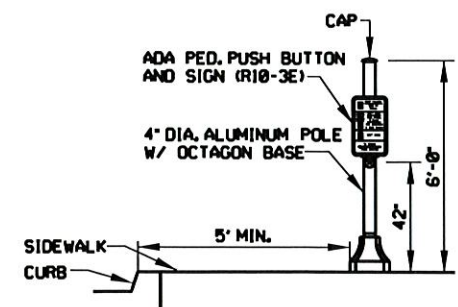

**TYPICAL MOUNTING DETAILS FOR PEDESTRIAN PUSH BUTTON POLE**

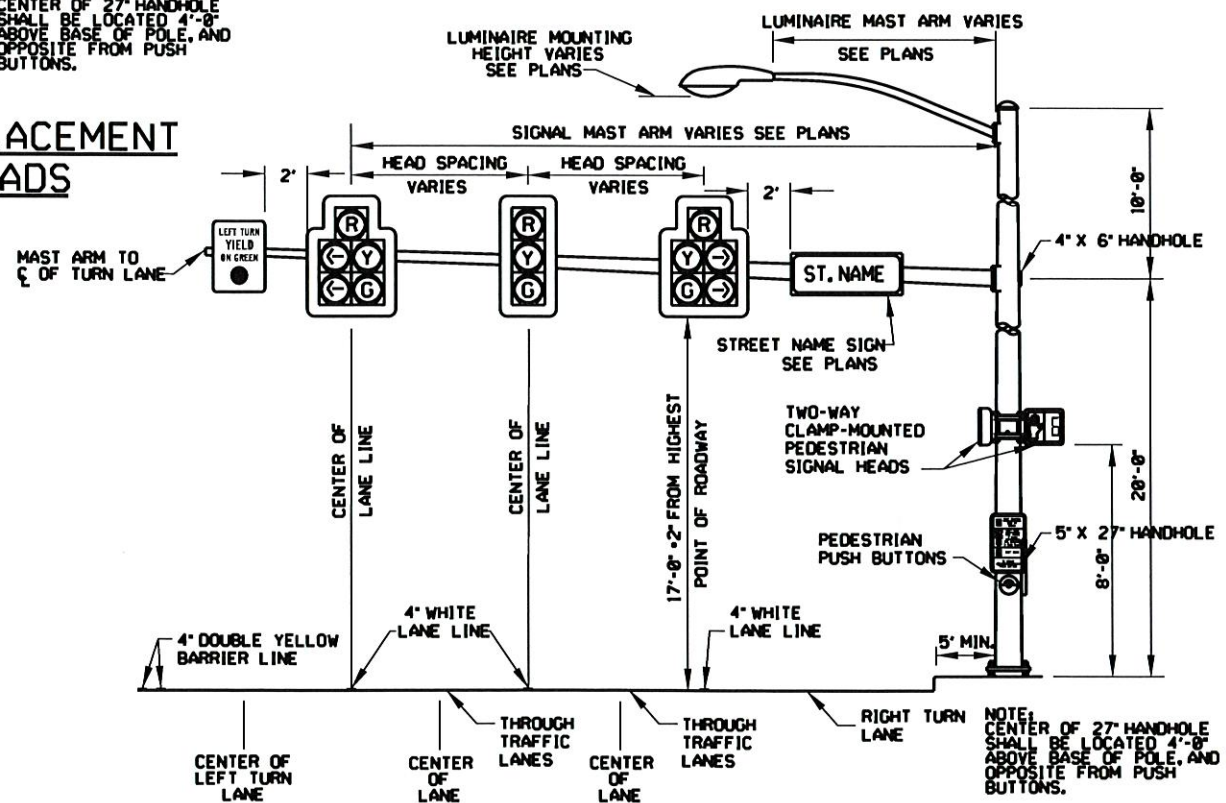

**TYPICAL SIGNAL EQUIPMENT PLACEMENT WITH PROTECTED/PERMISSIVE HEADS**

REVISION	BY	DATE

*[Signature]*  
CITY ENGINEER  
*[Signature]*  
CITY TRAFFIC ENGINEER

CITY OF TULSA, OKLAHOMA  
ENGINEERING SERVICES DEPARTMENT  
**PEDESTAL AND MAST ARM POLE DETAILS**  
DATE: AUGUST 2021  
STD. 613