

HORIZONTAL INJECTION POINT ALIGNMENT  
NOT TO SCALE

CHEMICAL PRESSURE GROUTING SYSTEM NOTES:  
SEE SPECIAL CONDITIONS FOR DETAILED CONSTRUCTION SPECS.

1. MANHOLE SHALL BE THOROUGHLY CLEANED PRIOR TO REHABILITATION.
2. ACTIVE INFLOW SHALL BE ELIMINATED PRIOR TO INJECTING GROUT.
3. URETHANE GEL GROUT SHALL BE UTILIZED FOR THE UPPER 5' OF THE MANHOLE. ACRYLAMIDE OR URETHANE GROUT SHALL BE USED FOR THE PORTION OF THE MANHOLE BELOW 5'. ALL GROUTING OPERATIONS SHALL BE IN STRICT ACCORDANCE WITH MANUFACTURER'S RECOMMENDATIONS AND SPECIFICATIONS.
4. PRIOR TO PRESSURE GROUTING, THE CONE SECTION INTERIOR OF THE MANHOLE SHALL BE COATED WITH A LAYER OF DRY POLYMER MORTAR. NO DRILLING OR PRESSURE GROUTING SHALL BE DONE UNTIL THE DRY POLYMER MORTAR HAS DRIED 24 HOURS.
5. INJECTION HOLES SHALL BE DRILLED AT 90° ANGLES FROM EACH OTHER AT THE SAME ELEVATION. TWO ROWS SHALL BE DRILLED FOR EACH JOINT, 6" ABOVE AND 6" BELOW THE JOINT. INJECTION HOLES SHALL BE PATCHED WITH A WATERPROOF QUICK-SETTING MORTAR.
6. ALL PRECAST MANHOLES WITH INTERIOR REHABILITATION SHALL HAVE JOINTS GROUTED.

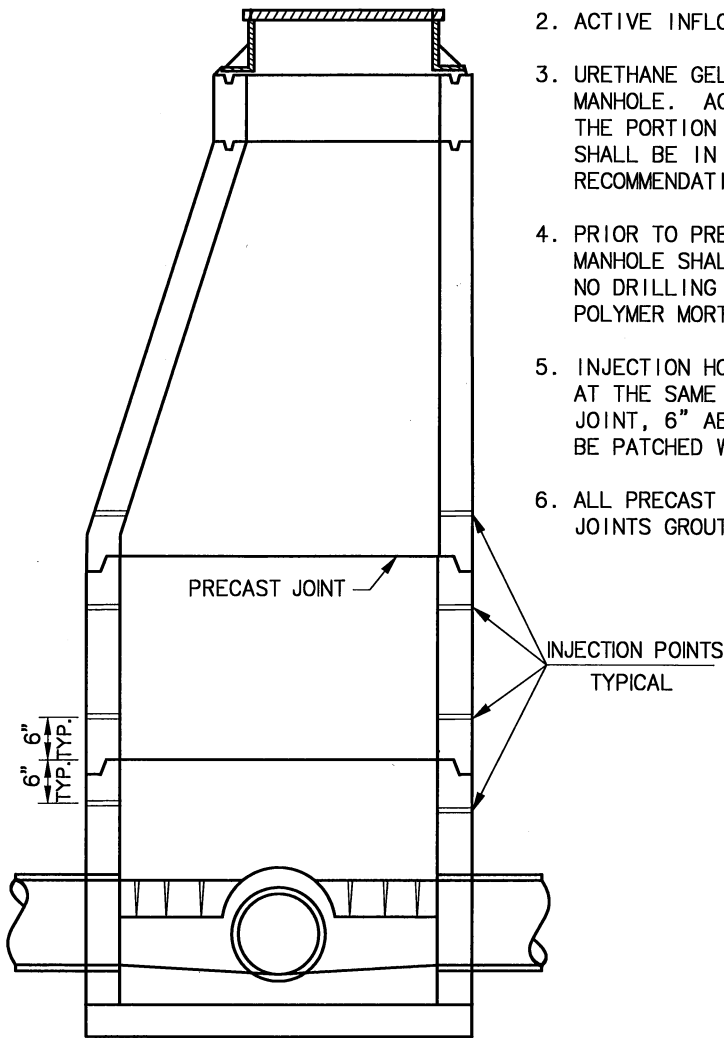

SECTION A-A

CHEMICAL PRESSURE GROUTING -  
PRECAST MANHOLE JOINTS  
NOT TO SCALE

CHEMICAL PRESSURE GROUTING PRECAST MANHOLE	
CITY OF TULSA, OKLAHOMA ENGINEERING SERVICES DEPARTMENT	
DRAWN BY: S.R.W.	APPROVED
CHECKED BY:	
DATE: OCTOBER 2013	
NOT TO SCALE	STANDARD NO. 411