

HORIZONTAL INJECTION POINT ALIGNMENT
NOT TO SCALE

CHEMICAL PRESSURE GROUTING SYSTEM NOTES:

SEE SPECIAL CONDITIONS FOR DETAILED CONSTRUCTION SPECS.

1. MANHOLE SHALL BE THOROUGHLY CLEANED TO MEET MANUFACTURER'S SPECIFICATIONS PRIOR TO REHABILITATION.
2. ACTIVE INFLOW SHALL BE ELIMINATED PRIOR TO INJECTING GROUT.
3. URETHANE GEL GROUT SHALL BE UTILIZED FOR THE ENTIRE MANHOLE. ALL GROUTING OPERATIONS SHALL BE IN STRICT ACCORDANCE WITH MANUFACTURER'S RECOMMENDATIONS AND SPECIFICATIONS.
4. ON BRICK MANHOLES OR SEVERELY DETERIORATED CONCRETE MANHOLES PRIOR TO PRESSURE GROUTING, THE ENTIRE INTERIOR SURFACE OF THE MANHOLE SHALL BE COATED WITH A LAYER OF DRY POLYMER MORTAR. NO DRILLING OR PRESSURE GROUTING SHALL BE DONE UNTIL THE DRY POLYMER MORTAR HAS DRIED 24 HOURS.
5. INJECTION HOLES SHALL BE DRILLED AT 90° ANGLES FROM EACH OTHER AT THE SAME PLANE OF ELEVATION. ADDITIONAL ROWS SHALL BE SEPARATED BY 18" AND STAGGERED WITH THE HOLES ABOVE AND BELOW. INJECTION HOLES SHALL BE PATCHED WITH A WATERPROOF QUICK SETTING MORTAR.

SURFACE GROUT AS NECESSARY, FULL CIRCUMFERENCE OF FRAME TO SEAL (8 INJECTION POINTS MINIMUM)

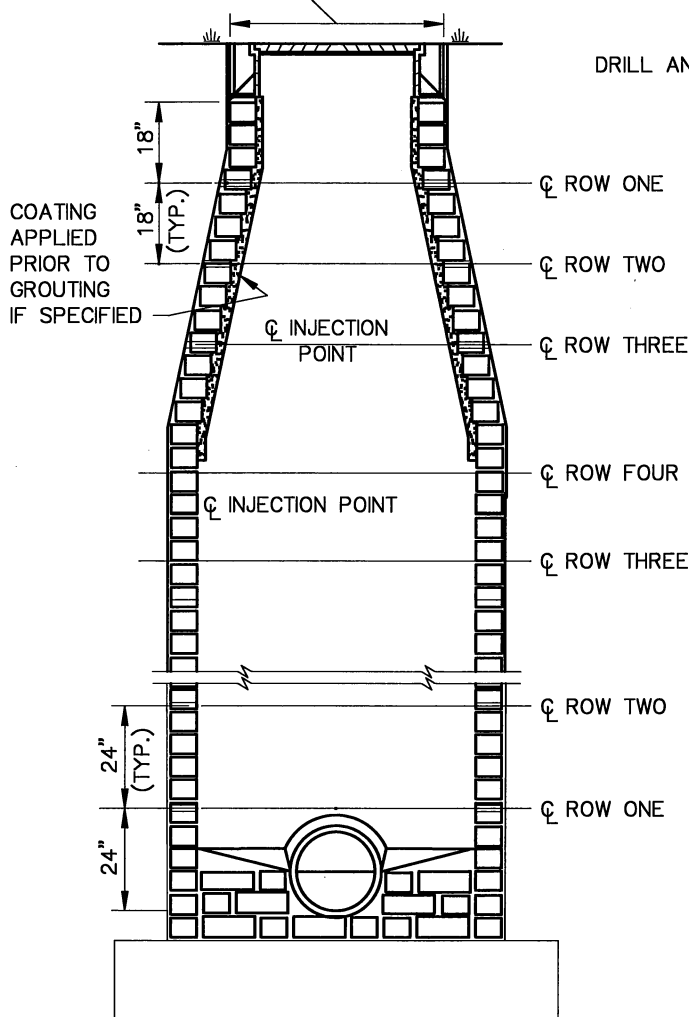

WALL/CORBEL CHEMICAL PRESSURE GROUTING DETAIL
NOT TO SCALE

COATED PIPE SEAL:
 DRILL AND GROUT PIPE SEAL:
 SURFACE GROUT:
 ① BONDING AGENT
 ② OCTOCRETE OR APPROVED EQUAL

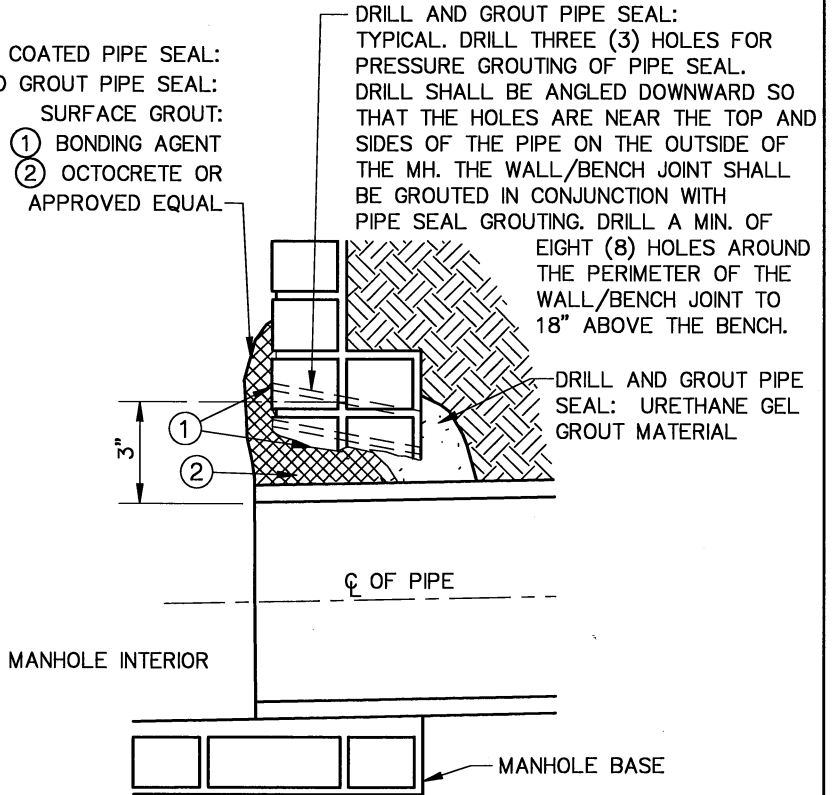

GROUTED AND COATED PIPE SEAL DETAIL
NOT TO SCALE

PATH NAME: /E1/PARTS/STD/DGN/STDS/412-CHEM-PRES-GRT.DGN LFM 05/25/2012

CHEMICAL PRESSURE GROUTING BRICK MANHOLE	
CITY OF TULSA, OKLAHOMA ENGINEERING SERVICES DEPARTMENT	
DRAWN BY: S.R.W. CHECKED BY: DATE: OCTOBER 2013	APPROVED
NOT TO SCALE	STANDARD NO. 412