

PATH NAME: /E1/PARTS/STD/DGN/STDS/725-STD-PAVE-PATCH.DGN SBW 07/19/2012

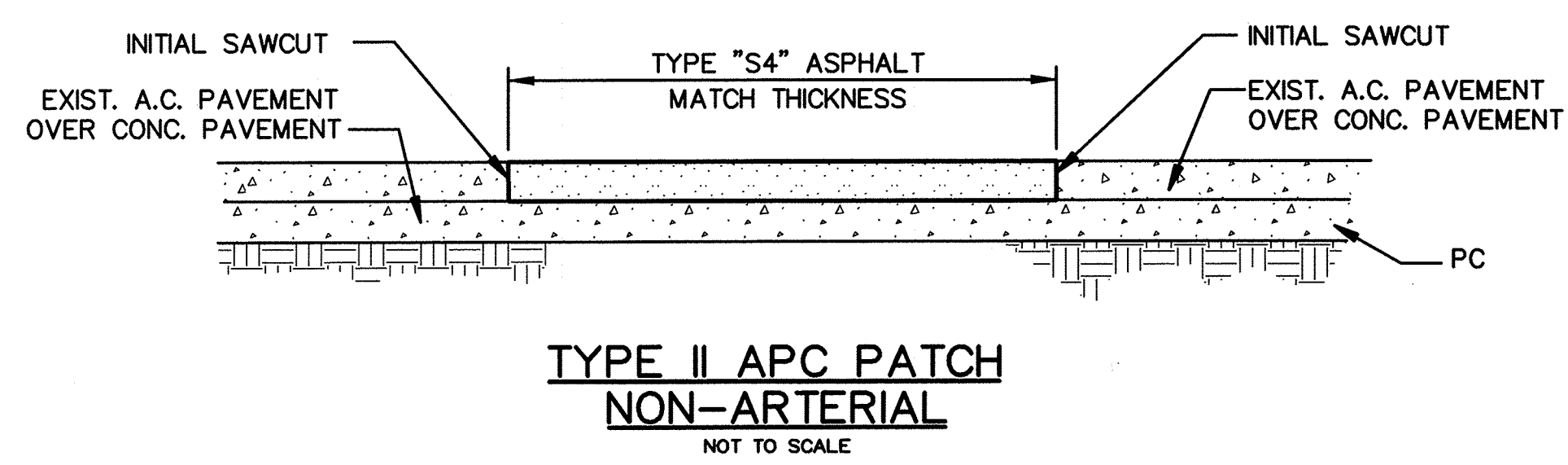
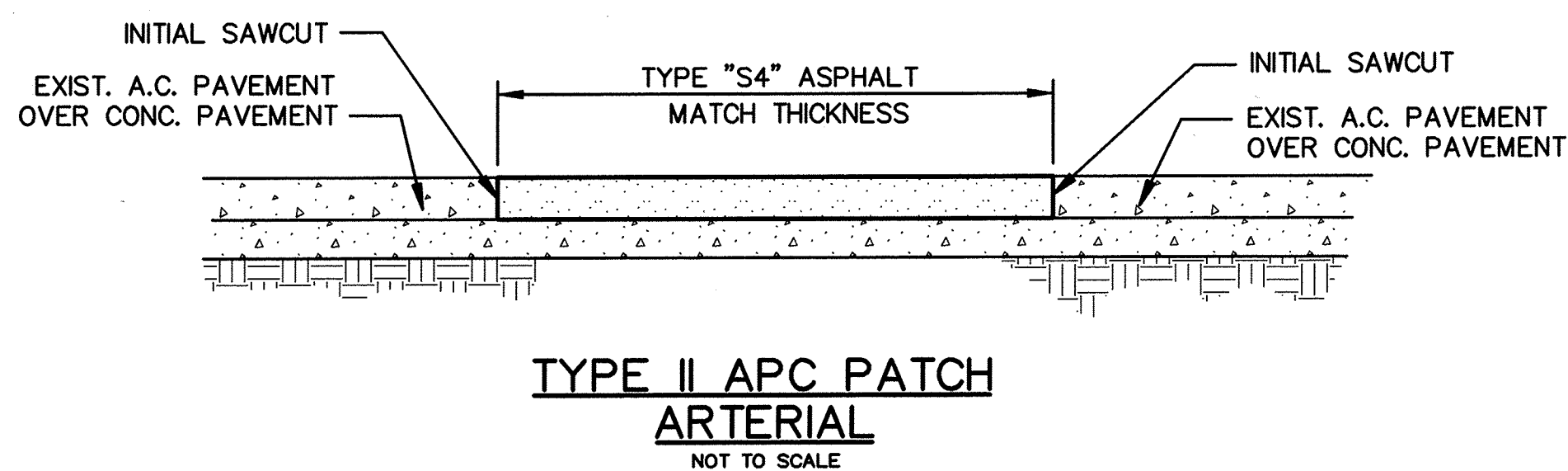
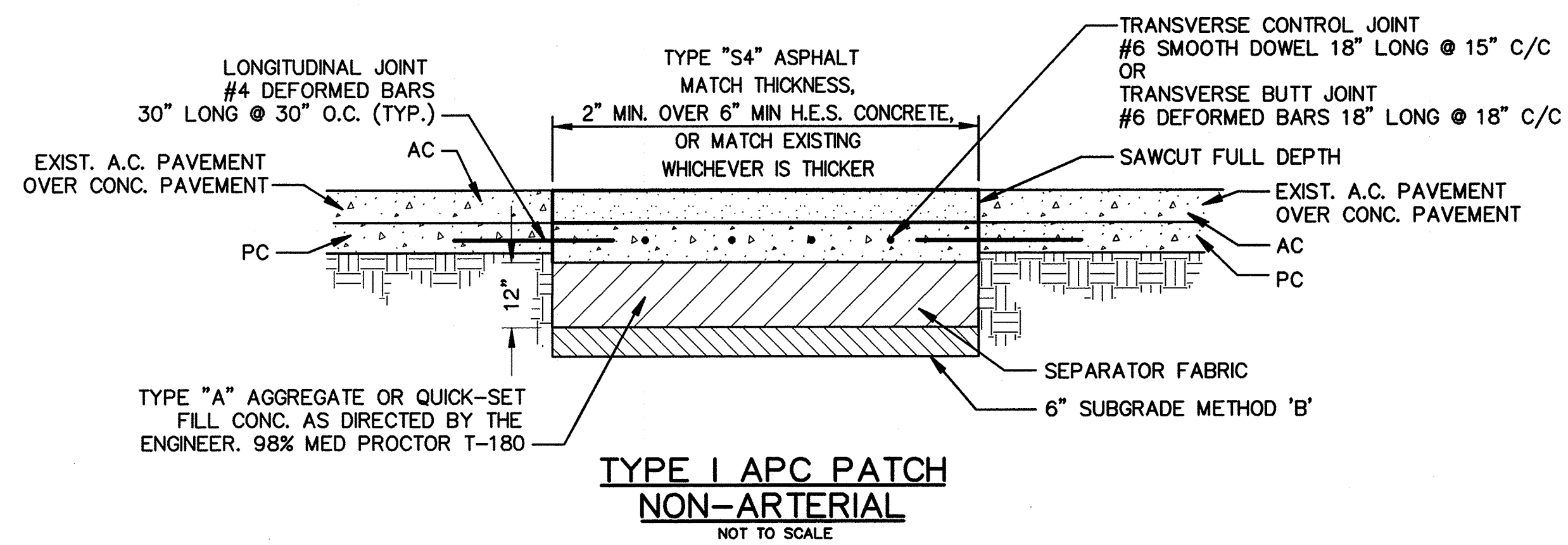
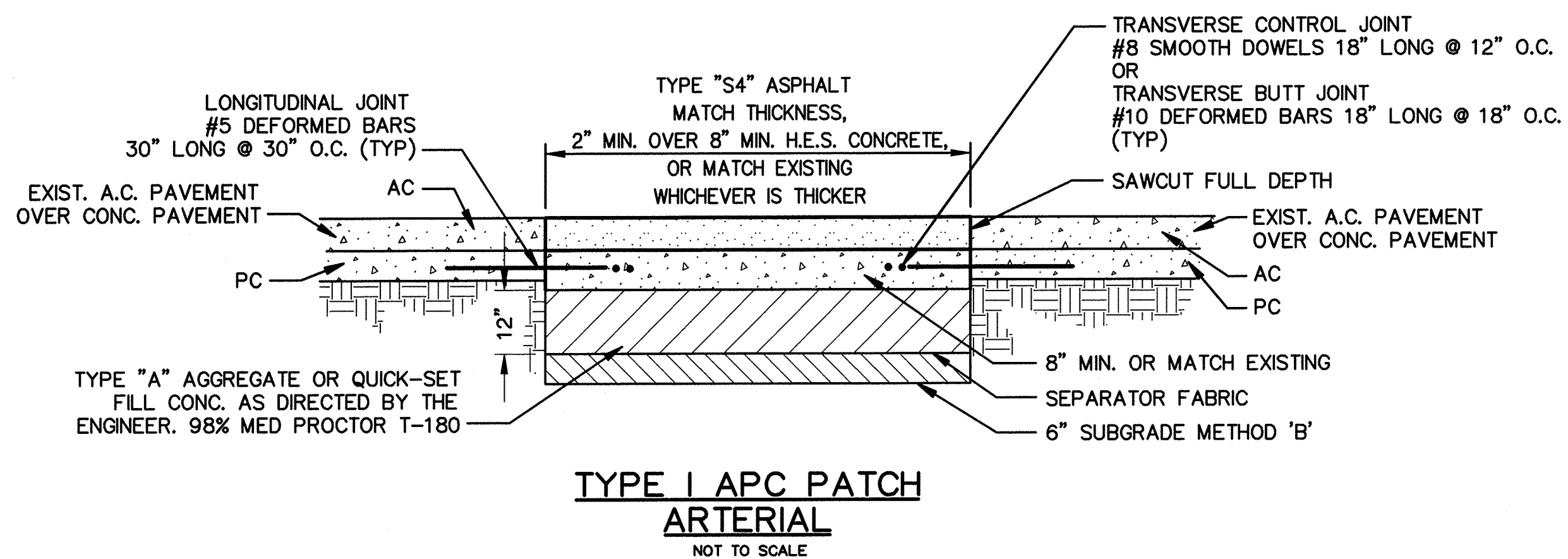
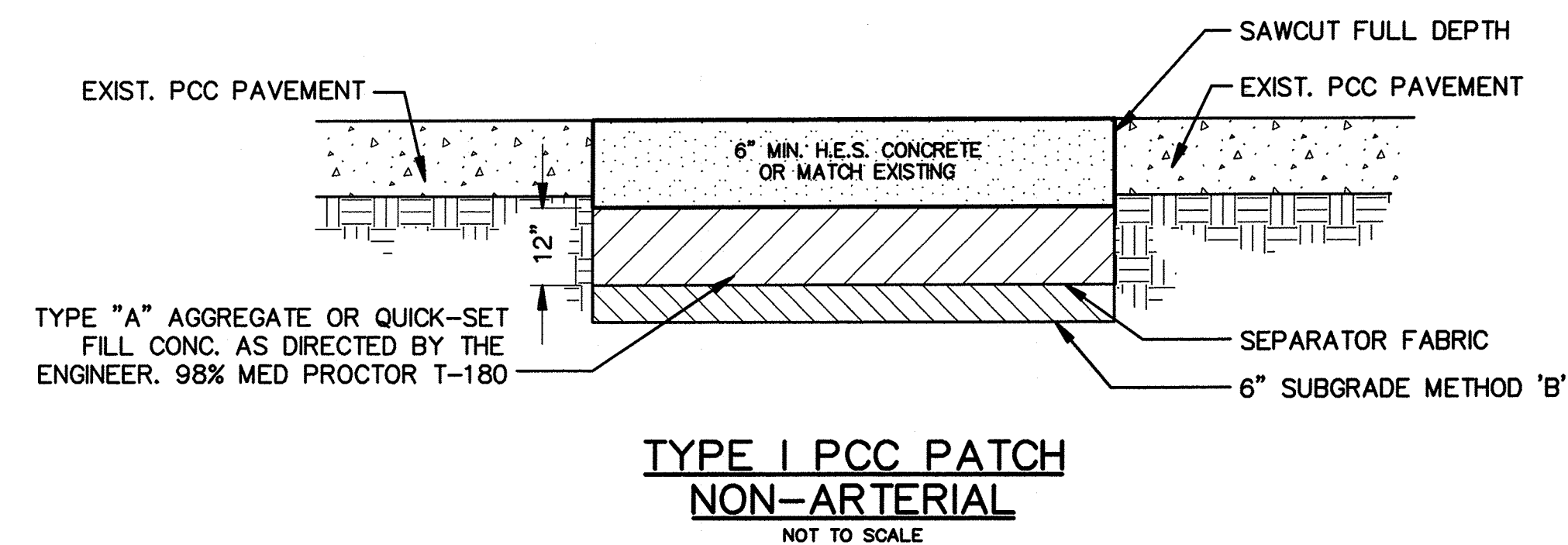
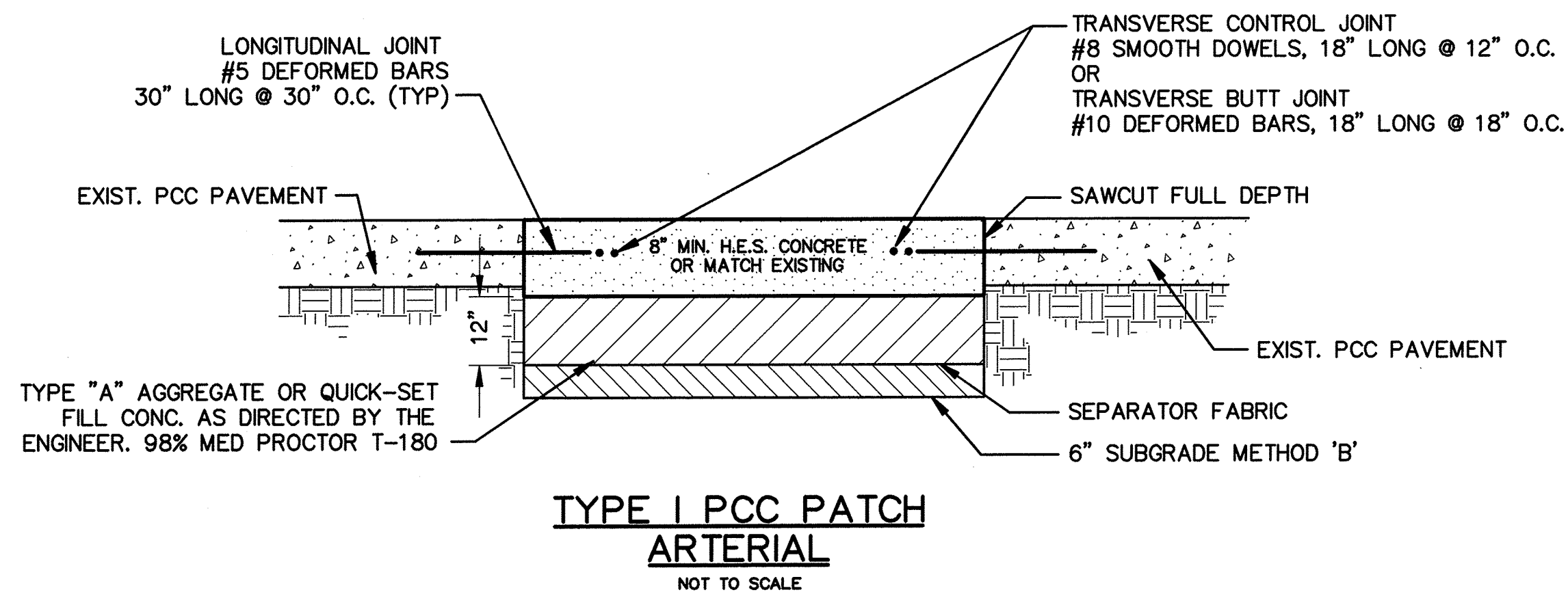
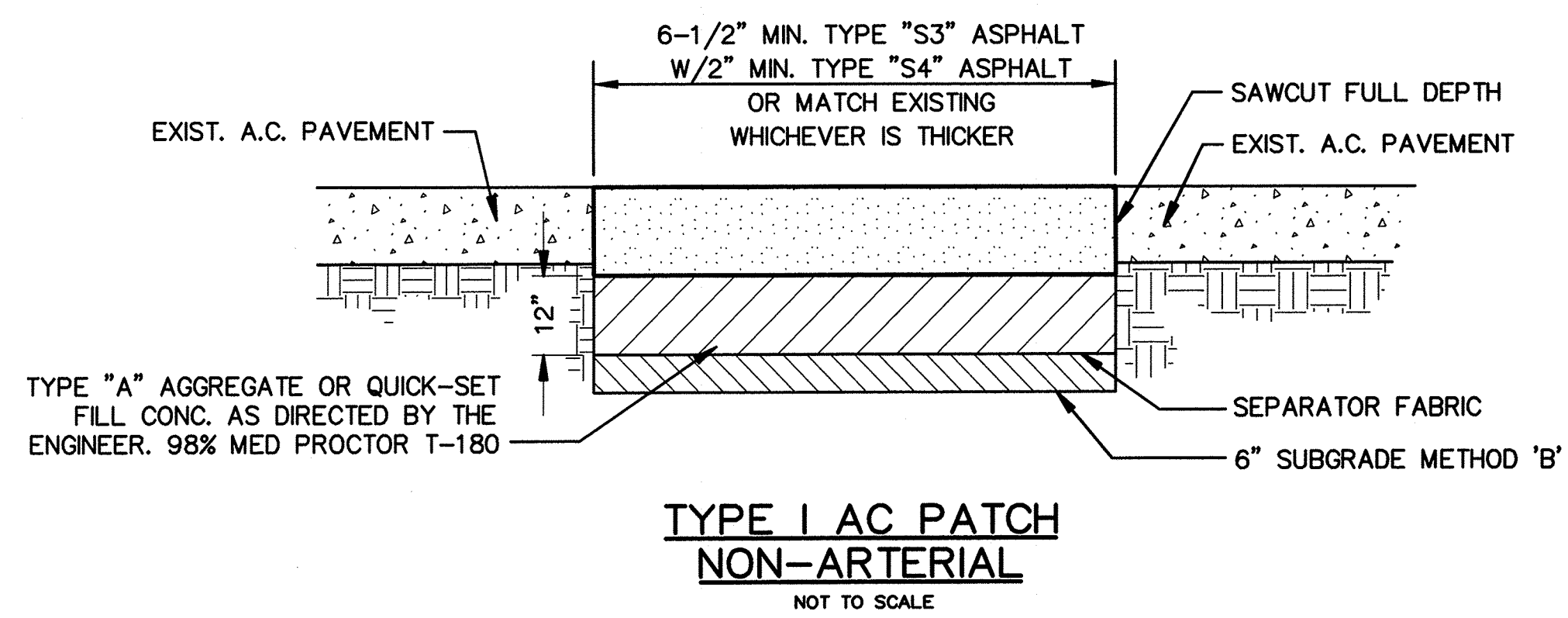
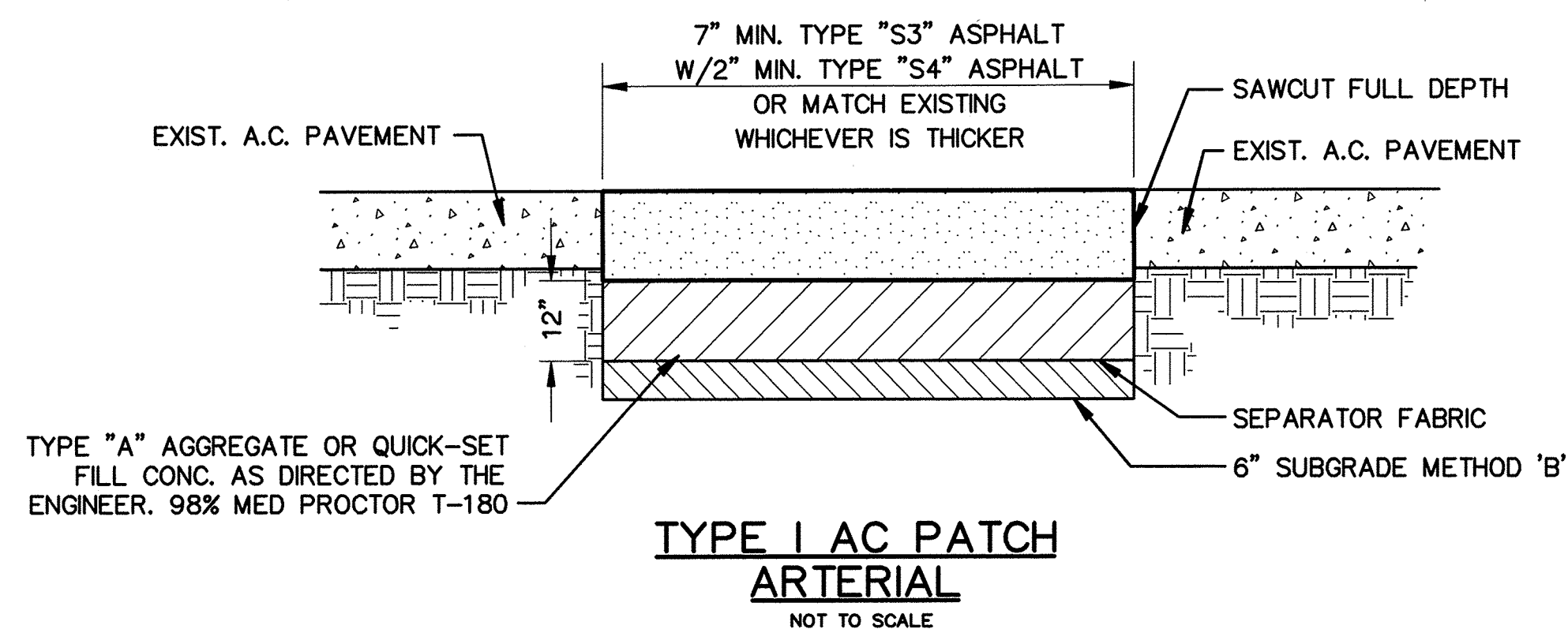

REVISION	BY	DATE

*[Signature]*  
CITY ENGINEER

*[Signature]*  
DESIGN MANAGER

CITY OF TULSA, OKLAHOMA  
ENGINEERING SERVICES DEPARTMENT

STANDARD PAVEMENT PATCH  
AND REPAIR

DATE: OCTOBER 2013

STD. NO. 725