

SECTION A-A
TYPE 'B' GRATE

MATERIAL:
CAST GRAY IRON ASTM A-48
CLASS 35-B 169 LBS.

LETTERED:
- PRODUCT NUMBER
- ASTM A48 CLASS 35B
- HEAT DATE AND NUMBER (OPTIONAL) *
- COMPANY LOGO (OPTIONAL)
* HEAT DATE AND NUMBER REQUIRED
IF NOT PART OF CAST DATE

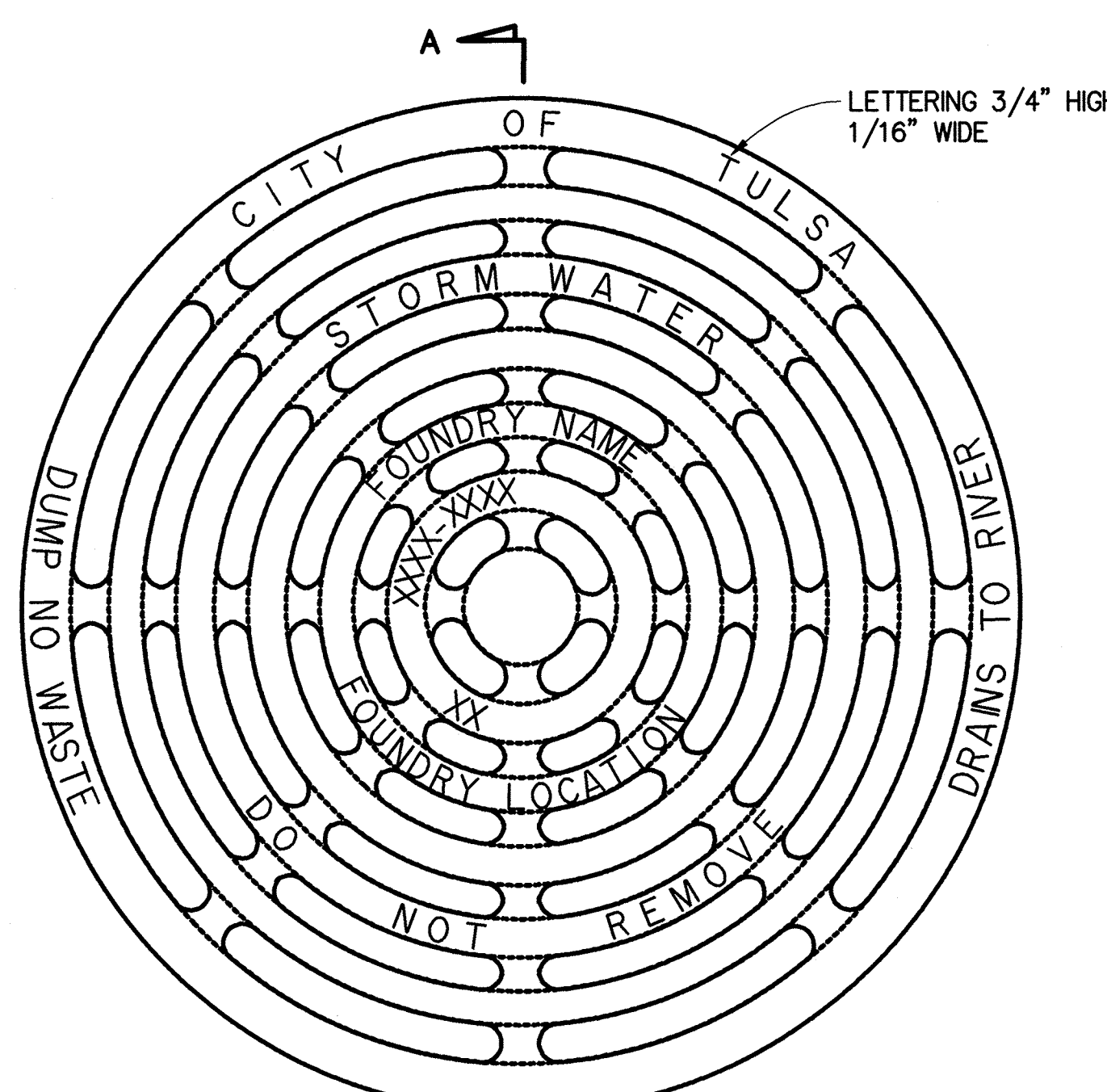

MATERIAL:
CAST GRAY IRON ASTM A-40
CLASS 35-B, 144 LBS.

INNER RING LETTERING
- CAST DATE
- ASTM A48 CLASS 35B
- HEAT DATE AND NUMBER (OPTIONAL) *
- COMPANY LOGO (OPTIONAL)
* HEAT DATE AND NUMBER REQUIRED
IF NOT PART OF CAST DATE

TYPE "D" GRATE

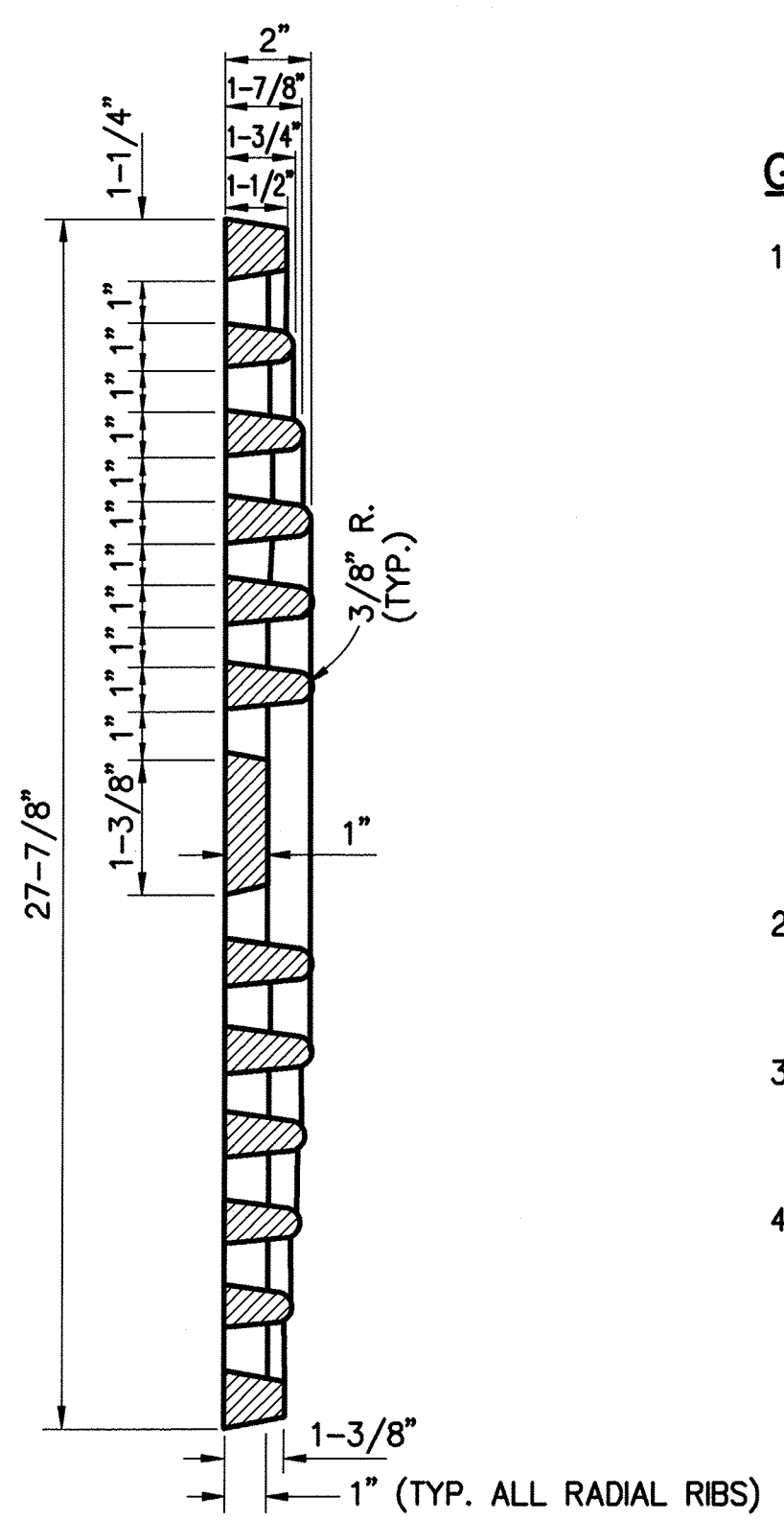

SECTION A-A

- GENERAL NOTES**
- CAST GRATING MAY BE OF GRAY IRON OR CAST STEEL OR DUCTILE IRON.

GRAY IRON GRATES SHALL CONFORM TO AND BE TESTED IN ACCORDANCE WITH THE STANDARD SPECIFICATION FOR GRAY IRON CASTINGS, ASTM A-48 AND DRAINAGE STRUCTURE CASTINGS, AASHTO DESIGNATION M306-89. GRAY IRON GRATES SHALL BE CLASS 35B OR BETTER.

CAST STEEL GRATES SHALL CONFORM TO THE REQUIREMENTS OF GRADE 65-35, FULL ANNEALED ACCORDING TO ASTM SPECIFICATION SERIAL DESIGNATION A-27.

DUCTILE IRON GRATES SHALL CONFORM TO THE REQUIREMENTS OF THE ASTM SPECIFICATION A-536 SPECIAL GRADE 60-45-10.
 - NO WORDING OR MARKING OF ANY KIND OTHER THAN THOSE SHOWN IN THE PLAN WILL BE PERMITTED ON THESE CASTINGS.
 - ALL TYPE "C" GRATES ARE TO BE BOLTED TO THE FRAME AS SHOWN. BOLTED FRAMES WILL BE FURNISHED IN MAXIMUM 36" LENGTHS.
 - "DUMP NO WASTE - DRAINS TO RIVER" LETTERING MAY BE PLACED ON THE TOP OF THE BARRIER CURB OR THE INLET GRATE.

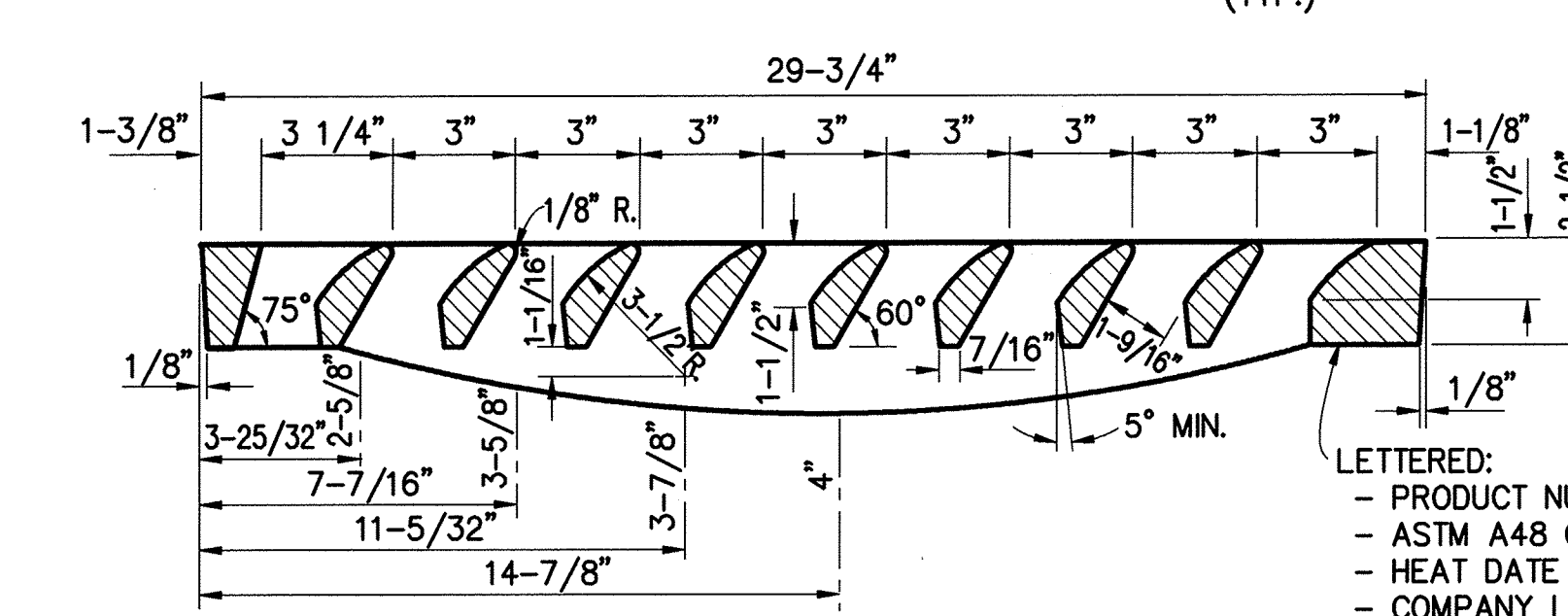
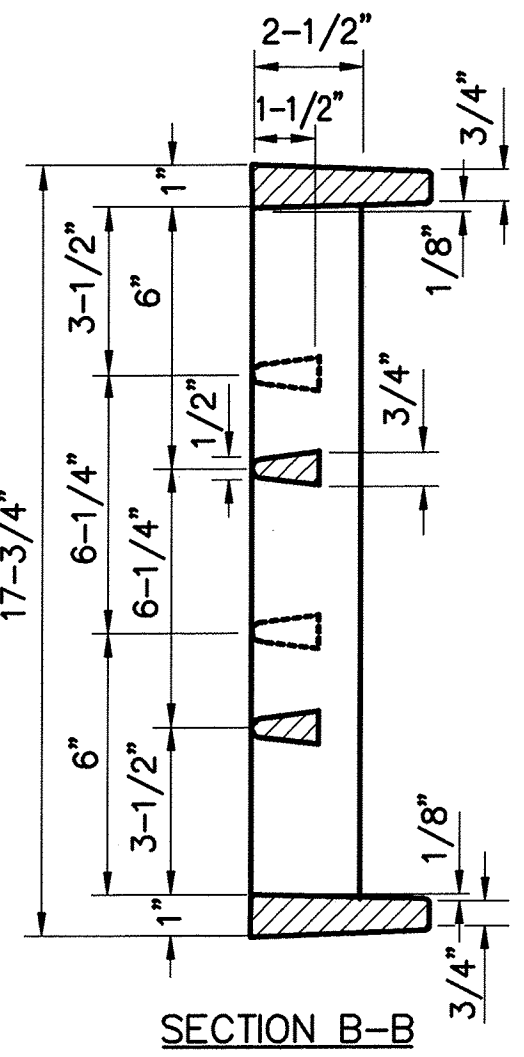
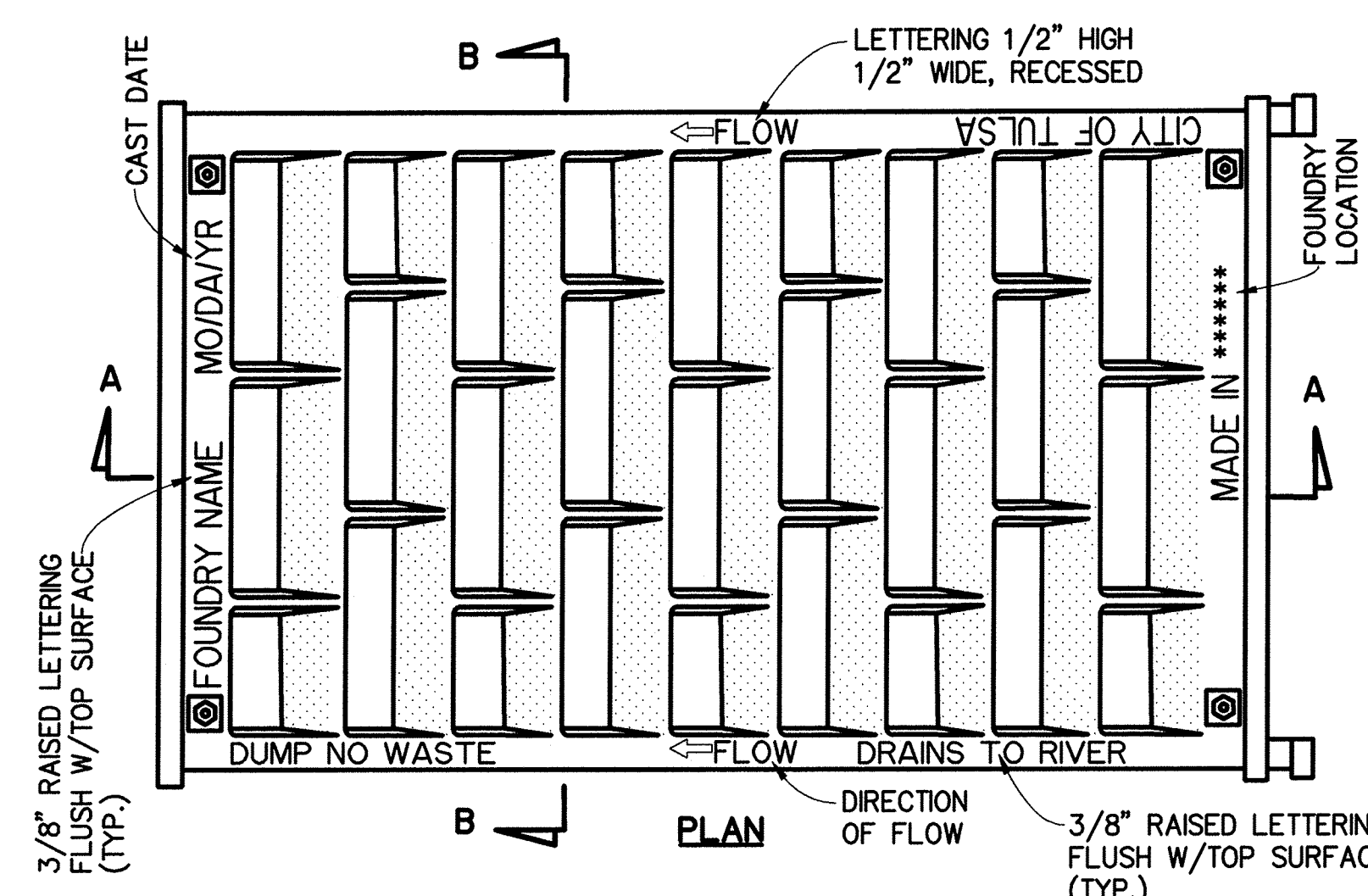

SECTION A-A
TYPE "C" GRATE

MATERIAL:
CAST GRAY IRON ASTM A-48
CLASS 35-B 160 LBS.

LETTERED:
- PRODUCT NUMBER
- ASTM A48 CLASS 35B
- HEAT DATE AND NUMBER (OPTIONAL) *
- COMPANY LOGO (OPTIONAL)
* HEAT DATE AND NUMBER REQUIRED
IF NOT PART OF CAST DATE

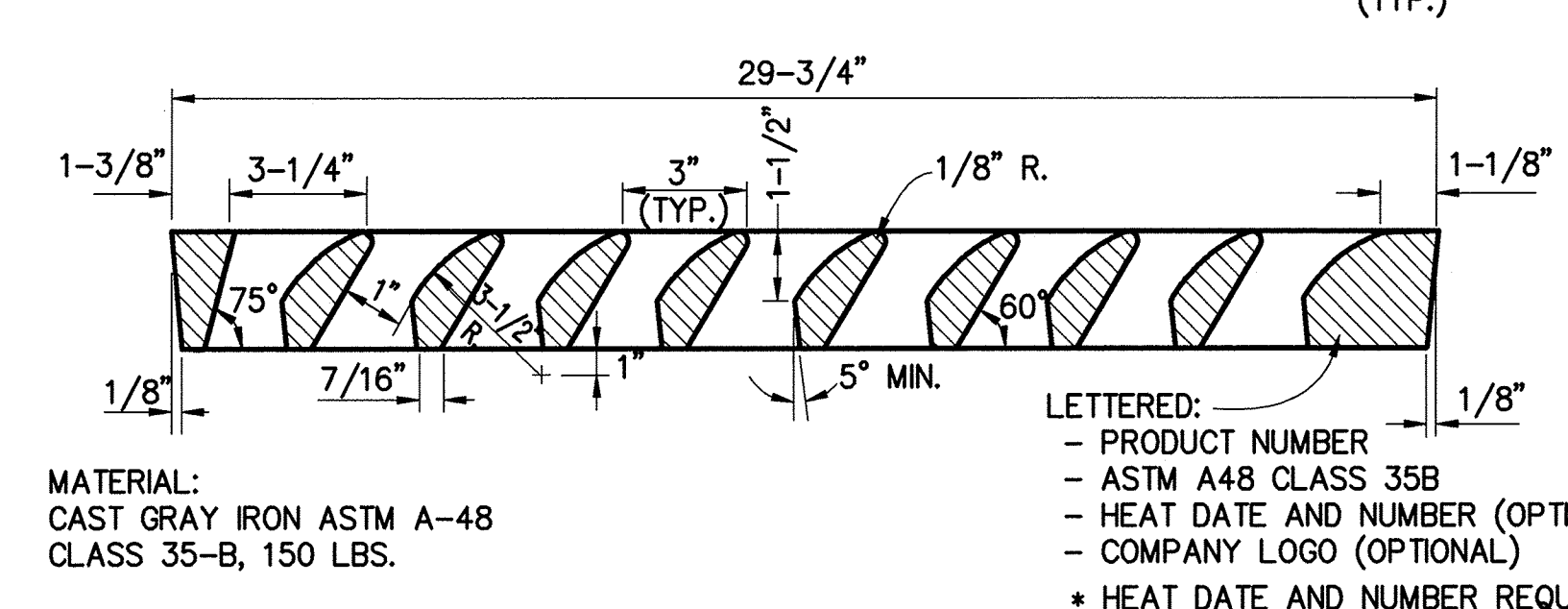
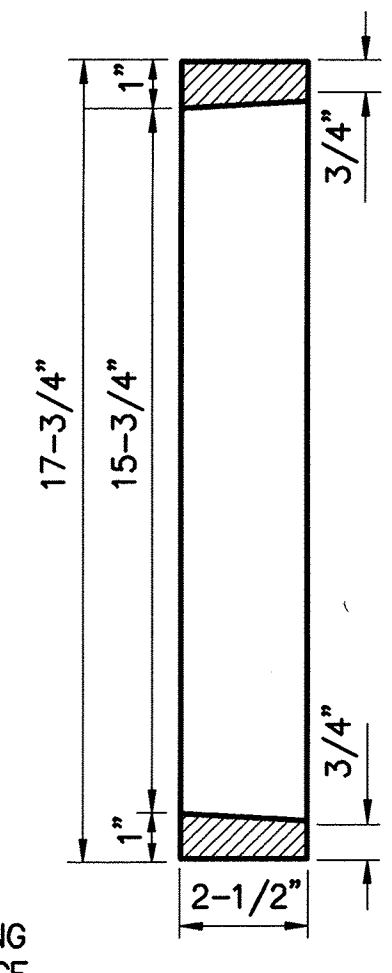
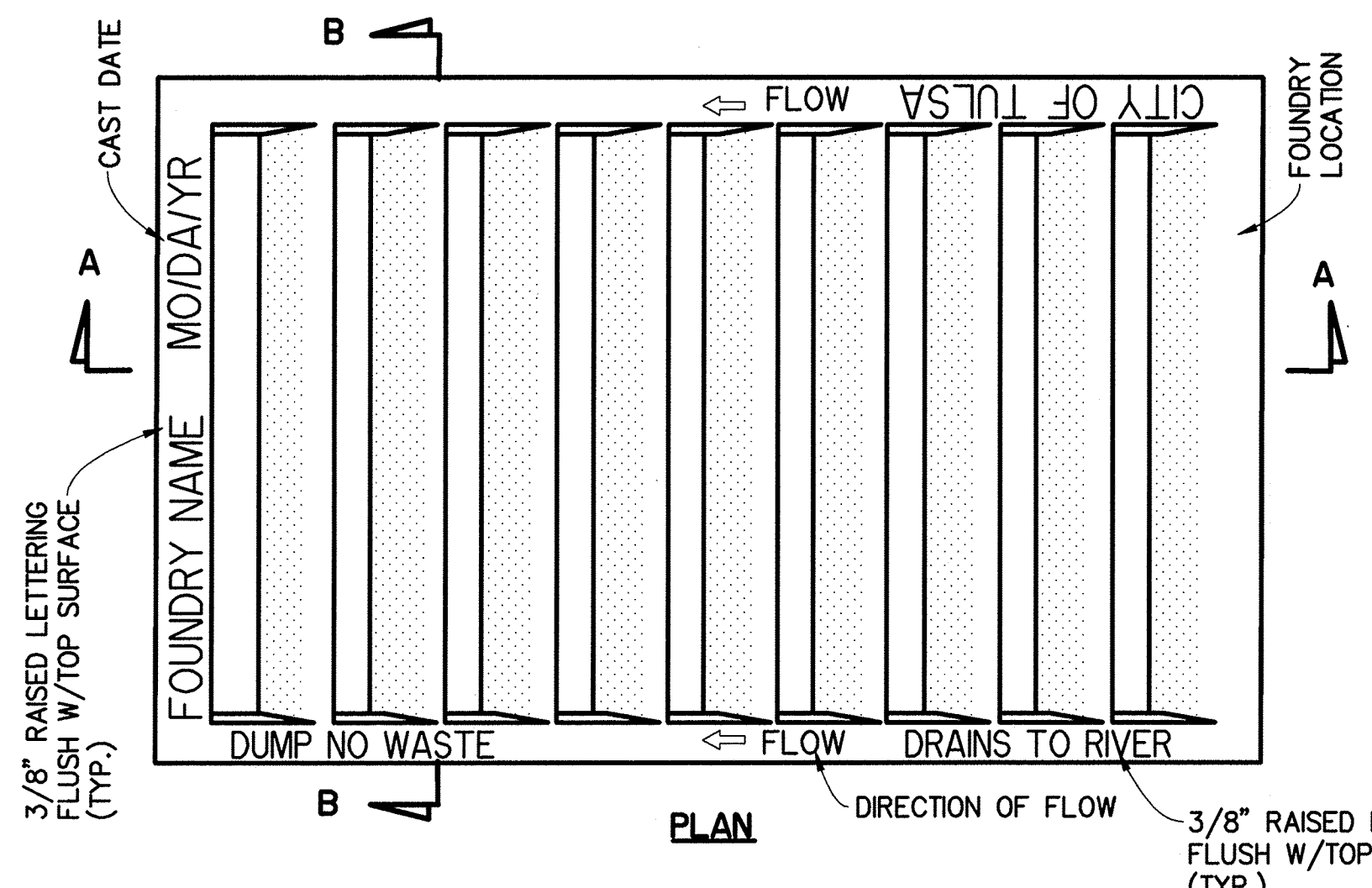

SECTION A-A
TYPE "A" GRATE

MATERIAL:
CAST GRAY IRON ASTM A-48
CLASS 35-B, 150 LBS.

LETTERED:
- PRODUCT NUMBER
- ASTM A48 CLASS 35B
- HEAT DATE AND NUMBER (OPTIONAL) *
- COMPANY LOGO (OPTIONAL)
* HEAT DATE AND NUMBER REQUIRED
IF NOT PART OF CAST DATE

TOLERANCES	INCHES	
	PLUS	MINUS
DIAMETER OF ROUND LIDS AND FRAME RECESS FOR ROUND LIDS	1/16	1/16
LENGTH AND WIDTH OF SQUARE OR RECTANGULAR LIDS	1/16	1/8
LENGTH AND WIDTH OF FRAME RECESS FOR SQUARE OR RECTANGULAR LIDS	1/8	1/16
METAL THICKNESS	1/16	1/16
ALL OTHER DIMENSIONS	1/8	1/8

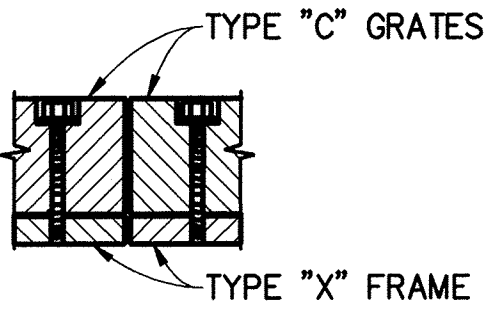

REVISION	BY	DATE

[Signature]
CITY ENGINEER

[Signature]
DESIGN MANAGER

CITY OF TULSA, OKLAHOMA
ENGINEERING SERVICES DEPARTMENT

STANDARD STORMWATER GRATES

DATE: OCTOBER 2013

STD. 766