

**CONTRACT DOCUMENTS  
AND  
SPECIFICATIONS  
FOR  
PROJECT NO. ES 2022-09 SPUNKY CREEK  
INTERCEPTOR MAIN STEM SOUTH PHASE 3**

---

**ATTENDANCE AT PRE-BID CONFERENCE IS MANDATORY**

---

PREPARED BY: RJNGROUP, INC  
4500 S Garnett Rd., Suite 110  
Tulsa, OK 74146  
Jacob Brumbaugh  
918-627-9737  
jbrumbaugh@rjnmail.com



**WATER AND SEWER**  
Engineering Design

ERIC LEE, DIRECTOR

---

Account Numbers: 2431S00011.SewerLines.Sewer.7500N.75003308.541101  
2531S00031.SewerLines.Sewer.7500N.75003308.541101  
2531S00031.SewerLines.Sewer.7524.75243300.541101

---

Public Works Department  
175 East 2<sup>nd</sup> Street, Suite 261  
Tulsa, Oklahoma 74103  
(918) 596-9637

CONTRACT DOCUMENTS

TULSA METROPOLITAN UTILITY AUTHORITY  
PROJECT NO. ES 2022-09  
SPUNKY CREEK INTERCEPTOR MAIN STEM SOUTH PHASE 3

WATER AND SEWER DEPARTMENT

INDEX TO BIDDING DOCUMENTS

	<u>PAGE</u>
NOTICE TO BIDDERS	NTB-1-3
INSTRUCTION TO BIDDERS	IB-1-6
RESOLUTION NO. 18145 PROVIDING FOR THE EMPLOYMENT OF RESIDENTS OF THE METROPOLITAN STATISTICAL AREA	R-1-3
RESOLUTION NO. 7404 AFFIDAVIT OF COMPLIANCE	RAC-1
AFFIDAVIT FOR 50% RESIDENT RESOLUTION	RRA-1
NONCOLLUSION AFFIDAVIT	NA-1
BUSINESS RELATIONSHIP AFFIDAVIT	BR-1
INTEREST AFFIDAVIT	IA-1
PROPOSAL	P-1-4
CERTIFICATE OF SECRETARY	CS-1
CONSENT OF MEMBERS	CM-1
SALES TAX EXEMPTION DOCUMENT	STED-1
EXTENSION OF TIME REQUEST	ETR-1
CONTRACT	C-1-4
ESCALATION PROCESS	EP-1
PERFORMANCE BOND	PB-1-2
STATUTORY BOND	SB-1-2
MAINTENANCE BOND	MB-1-2
AFFIDAVIT FOR CONTRACT/CLAIM	AC-1
GENERAL CONDITIONS	TMUAGC-1-20

SPECIAL PROVISIONS

SUPPLEMENTAL CONTRACT REQUIREMENTS	SCR-1
INSURANCE REQUIREMENTS	IR-1
OWNER ALLOWANCE	OA-1
COT PROJECT SIGN	PS-1
UTILITY RELOCATIONS AND DESIGN ISSUES	URDI-1

SPECIFICATIONS

CITY OF TULSA ENGINEERING SERVICES CONSTRUCTION  
SPECIFICATIONS – March 2022

TECHINCAL SPECIFICATIONS	1-38
--------------------------	------

Published in the Tulsa World:  
June 26, 30 & July 1, 2, 3 2026

**NOTICE TO BIDDERS  
SEALED BIDS FOR  
TULSA METROPOLITAN UTILITY AUTHORITY  
PROJECT NO. ES 2022-09**

Notice is hereby given that pursuant to an order by the Tulsa Metropolitan Utility Authority, a Public Trust, sealed bids will be received in Room 260 of the Office of the City Clerk, City of Tulsa, 175 E. 2<sup>nd</sup> Street, Tulsa, Oklahoma 74103 until **8:30 a.m., 31<sup>st</sup> day of July, 2026** for furnishing all tools, materials and labor and performing the work necessary to be done in the construction of the following:

**PROJECT NO. ES 2022-09 SPUNKY CREEK INTERCEPTOR  
MAIN STEM SOUTH PHASE 3**

The entire cost of the improvement shall be paid from Account No.

A **MANDATORY** Pre-Bid Conference is scheduled for **Tuesday, July 7<sup>th</sup>, 2026 at 9:00 a.m.** and will be held through video conferencing with Microsoft Teams, invitation presented on the City of Tulsa's website at this link:

<https://www.cityoftulsa.org/government/departments/engineering-services/construction-bids/>

**Attendance at the Pre-Bid Conference is MANDATORY. Bids will not be received from contractors who did not attend the Pre-Bid Conference.**

Bids will be accepted by the City Clerk from the holder of valid pre-qualification certificates from the City of Tulsa in one or more of the following classifications: **A or D**

Drawings, specifications and contract documents for construction of said public improvements of the said project have been adopted by the Mayor of said City. Copies of same may be obtained at the Office of Contract Administration, 175 E. 2<sup>nd</sup> St., 13<sup>th</sup> Floor, Tulsa, OK 74103 for a non-refundable fee in the amount of **\$50.00** made payable to the Tulsa Metropolitan Utility Authority by check or money order.

Contract requirements shall include compliance as required by law pertaining to the practice of non-discrimination in employment. Attention is called to Resolution No. 18145 of August 23, 1988, requiring bidders to commit to the goal of employing on the project at least fifty percent bona fide residents of the City of Tulsa and/or MSA in each employment classification.

Attention is called to Resolution 7404 of November 8, 2006, requiring bidders, their subcontractors and their lower-tier subcontractors to hire only citizens of the United States.

The Authority, acting on behalf of the City of Tulsa, is exempt from the payment of any sales or use taxes, and pursuant to Title 68 O.S. Section 1356(10), direct vendors to the Authority are also exempt from those taxes. A bidder may exclude from his bid appropriate sales taxes which he will not have to pay while acting for and on behalf of the Tulsa Metropolitan Utility Authority. See Contract Article IIB.

A Certified or Cashier's Check or Bidder's Surety Bond, in the sum of 5% of the amount of the bid will be required from each bidder to be retained as liquidated damages in the event the successful bidder fails, neglects or refuses to enter into said contract for the construction of said public improvements for said project and furnish the necessary bonds within thirty days from and after the date the award is made.

The bidder to whom a contract is awarded will be required to furnish public liability and workmen's compensation insurance; Performance, Statutory, and Maintenance bonds acceptable to the Authority, in conformity with the requirements of the proposed contract documents. The Performance, Statutory, and Maintenance bonds shall be for one hundred percent (100%) of the contract price.

The bidding for this project is subject to a local preference law as defined in Oklahoma Statutes, Title 61, Section 103. For purposes of Section 103 a "local bid" means a bid submitted by a business entity that is authorized to do business in the State of Oklahoma and maintains its primary office or principal place of business within the State of Oklahoma. If the conditions outlined in Title 61 are met, The City of Tulsa must select the second lowest bid if within 5% of the lowest bid and the second lowest bid is a local bid and the lowest bid is not a local bid (i.e. non-local/out of state). Accordingly, when the local bid is required to be selected under the State law, the local bidder must agree to do the work at the lowest bid price to be awarded the project.

All bids will be opened and considered by the Bid Committee of said City at a meeting of said Committee to be held in the City Council Room of City Hall, 175 E. 2<sup>nd</sup> Street, in said City at 9:00 a.m. on the 31<sup>st</sup> day of July, 2026.

Dated at Tulsa, Oklahoma, this 26<sup>th</sup> day of June, 2026.

(SEAL)

Lou Reynolds  
Tulsa Metropolitan Utility Authority

## INSTRUCTIONS TO BIDDERS

### **B-1. BIDS**

Each bid Proposal shall be completed, signed, and submitted. No alterations, additions, or erasures shall be made on the Proposal. Erroneous entries shall be lined out, initialed by the bidder, and the correct entry inserted. The unit price bid must cover all expense for furnishing the labor, materials, tools, equipment, and apparatus of every description to construct, erect, and furnish all work required by and in conformance with the Drawings and Specifications.

Each bid shall be enclosed in a sealed envelope addressed to the Tulsa Metropolitan Utility Authority, 175 E. 2<sup>nd</sup> Street, Room 260, City Hall, Tulsa, Oklahoma, identified on the outside with the words:

### **PROJECT NO. ES 2022-09 SPUNKY CREEK INTERCEPTOR MAIN STEM SOUTH PHASE 3**

Pre-qualification Certificate Number \_\_\_\_\_.

And shall be filed with the City Clerk in Room 260, City Hall.

All addenda to the contract documents should be denoted on the last page of the Proposal in the space provided.

### **B-2. BID SECURITY**

Each bid shall be accompanied by a cashier's check, a certified check, or bidder's bond, in the amount of five percent (5%) of the total amount bid.

The bid security shall be made payable, without condition, to the Tulsa Metropolitan Utility Authority, Oklahoma. The bid security may be retained by and shall be forfeited to the Authority as liquidated damages if the bid is accepted, a contract based thereon is awarded, and the bidder fails to enter into a contract in the form prescribed, with legally responsible sureties, within thirty (30) days after such award is made by the Authority.

### **B-3 RETURN OF BID SECURITY**

The bid security of each unsuccessful bidder will be returned when his bid is rejected. The bid security of the bidder to whom the contract is awarded will be returned when he executes a contract and files satisfactory bonds. The bid security of the second lowest responsible bidder may be retained for a period of time not to exceed sixty (60) days pending the execution of the contract and bonds by the successful bidder.

**B-4 WITHDRAWAL OF BIDS**

No bidder may withdraw his bid for sixty (60) days after the date and hour set for the opening. A bidder may withdraw his bid any time prior to expiration of the period during which bids may be submitted by making a written request signed in the same manner and by the same person who signed the Proposal.

**B-5 REJECTION OF BIDS**

Bids received more than ninety-six (96) hours before the time set for opening bids, excluding Saturdays, Sundays, and holidays, as well as bids received after the time set for opening bids, will not be considered and will be returned unopened.

The Tulsa Metropolitan Utility Authority reserves the right to reject any and all bids when such rejection is in the best interest of the Tulsa Metropolitan Utility Authority. All bids are received subject to this stipulation and the Authority reserves the right to decide which bidder shall be deemed lowest responsible bidder.

A violation of any of the following provisions by a bidder shall be sufficient reason for rejecting bidder's bid, or shall make any contract between the Tulsa Metropolitan Utility Authority and the Contractor that is based on bidder's bid, null and void: divulging the information in said bid before the bids have been opened; submission of a bid which is incomplete, unbalanced, obscure, incorrect, or which has conditional clauses, additions, or irregularities of any kind not in the original proposal form, or which is not in compliance with the Instruction to Bidders and published Notice to Bidders, or which is made in collusion with another bidder. The Authority shall have the right to waive any immaterial defects or irregularities in any bid received.

**B-6 DISQUALIFICATION OF BIDDERS**

No contract will be awarded to any person or persons, firm, partnership, company, or corporation which is in arrears to the Authority upon any debt of contract, or in default as surety or otherwise upon any obligation to the Authority.

**B-7 SIGNATURE OF BIDDERS**

Each bid shall be properly signed with the full name of the company or individual submitting the bid, the bidder's address, and the name and title of all persons signing printed below their signature lines. Bids by partnerships shall be signed with the partnership name followed by the signature and title of one of the partners. Bids by corporations shall be signed with the name of the corporation followed by the signature and title of the president, vice president, chairman, or vice chairman of the Board of Directors with attestation by the corporate secretary or assistant corporate secretary. Bids by joint ventures shall be signed by each participant in the joint venture. Bids by limited liability companies shall be signed with the name of the limited liability company followed by the signature

and title of the Manager or Managing Member. Bid by limited partnerships shall be signed with the name of the limited partnership followed by the signature of the general partner. Note: The signature requirements listed above are for Oklahoma entities; entities organized in other states must follow the law of the state in which they are organized.

A bid by a person who affixes to his signature the word "President", "Manager", "General Partner", "Agent", or other title, without disclosing the name of the company for which he is signing, may be held to be the bid of the individual signing.

#### **B-8 INTERPRETATION OF CONTRACT DOCUMENTS**

If any bidder who contemplates submitting a bid is in doubt as to the true meaning of any part of the drawing, specifications, or other proposed contract documents, bidder may submit to Contract Administration and the Engineer a written request for interpretation thereof. The person submitting the request shall be responsible for its prompt delivery. Interpretation of the proposed contract documents will be made only by addendum. The addendum will be posted on the Tulsa Metropolitan Utility Authority website and emailed to all the pre-bid attendees. The Authority will not be responsible for any other explanations or interpretations of the proposed contract documents.

#### **B-9 LOCAL CONDITIONS AFFECTING WORK**

Each bidder shall visit the site of the work and shall completely inform himself relative to construction hazards and procedure, labor, and all other conditions and factors, local and otherwise, which would affect prosecution and completion of the work and its cost. Such considerations shall include the arrangement and condition of existing structures and facilities, the procedure necessary for maintenance of uninterrupted operation of existing structures and facilities, the availability and cost for labor, and facilities for transportation, handling, and storage of materials and equipment. All such factors shall be properly investigated and considered in the preparation of the bid. There will be no subsequent financial adjustment for lack of such prior information.

#### **B-10 TIME OF COMPLETION**

The time of completion is an essential part of the contract and it will be necessary for each bidder to satisfy the Authority of his ability to complete the work within the allowable time set forth in the Bid Form. For all projects that will impact the public, a public meeting is required before any work is done. In this connection, attention is directed to the provisions of the General Conditions and Special Conditions relative to delays, extension of time, and liquidated damages.

#### **B-11 QUALIFICATION OF BIDDERS**

No bid will be received and filed by the City Clerk of the Tulsa Metropolitan Utility Authority unless the person submitting the bid has been pre-qualified as provided

by ordinance, and is the holder of a current certificate of Pre-qualification in force and effect on the date such bid is to be submitted and filed.

## **B-12 TAXES AND PERMITS**

Attention is directed to the requirements of the General Conditions regarding payment of taxes and obtaining permits. Contractor shall comply with all zoning ordinances of the City, as provided in the Tulsa Zoning Code, Title 42 Tulsa Revised Ordinances and conform with all zoning requirements established by the Tulsa Metropolitan Area Planning Commission and the Board of Adjustment. Contractor can call the Indian Nations Council of Governments (INCOG) at (918) 584-7526, to determine if any zoning requirements must be met.

## **B-13 OKLAHOMA LEGAL REQUIREMENTS**

The Contractor must comply with the Oklahoma Scaffolding Law, 40 Oklahoma Statutes, Sections 174 - 177, which cover erection and use of scaffolds, hoists, cranes, stays, ladders, supports, or other mechanical contrivances.

In accordance with Oklahoma Statutes, Title 68, Section 1701-1707, before commencing any work pursuant to this contract, any nonresident contractor shall give written notice by certified mail, return receipt requested, to the Oklahoma Tax Commission, the Oklahoma Employment Security Commission, the Workers Compensation Court, and the county assessor of each county in which work will be performed. The notices shall comply with the requirements set forth in said statute.

## **B-14 BONDS**

The bidder to whom a contract is awarded will be required to furnish bonds as follows:

- a. Performance Bond – A Performance Bond to the Authority in an amount equal to one hundred percent (100%) of the Contract price.
- b. Statutory Bond – A Statutory Bond to the State of Oklahoma in an amount equal to one hundred percent (100%) of the contract price.
- c. Maintenance Bond – A Maintenance Bond to the Authority in an amount equal to one hundred percent (100%) of the contract price.

The bonds shall be executed on the forms included in the contract documents by a surety company authorized to do business in the State of Oklahoma and acceptable as Surety to the Tulsa Metropolitan Utility Authority.

Accompanying the bonds shall be a "Power-of-Attorney" authorizing the attorney-in-fact to bind the Surety Company and certified to include the dates of the bonds.

**B-15 BOUND COPY OF CONTRACT DOCUMENTS**

Bound contract documents are no longer required.

**B-16 EQUAL EMPLOYMENT OPPORTUNITY REQUIREMENTS**

Each bidder agrees to comply with the terms of Title 5, Chapter 1, Section 111, of the Tulsa Revised Ordinances relating to Non-Discrimination.

**B-17 BASIS FOR AWARD OF CONTRACT**

The basis for award of a contract shall be the total base bid submitted by the lowest responsible bidder unless otherwise directed in the form of proposal. The Tulsa Metropolitan Utility Authority reserves the right to withhold the awarding of a contract for a reasonable period of time from the date of opening of bids. The awarding of a contract upon a successful bid shall give the bidder no right or action or claim against the Tulsa Metropolitan Utility Authority upon such contract until the same shall have been reduced to writing and duly signed by the contracting parties. The award of a contract will not be completed until the contract is duly executed and the necessary bonds and insurance approved.

**B-18 TIME FOR AWARDING OF CONTRACT**

The awarding of a contract to the lowest responsible bidder will be made within thirty (30) days after the opening of bids unless the Tulsa Metropolitan Utility Authority by formal recorded action and for good cause shown, provides for a reasonable extension to that period, which extension period shall not in any event exceed fifteen (15) days where only state or local funds are involved, or not to exceed ninety (90) days on any award of contract for the construction of public improvements where funds are utilized which are furnished by an agency of the federal government.

**B-19 SAFETY AND HEALTH REGULATIONS**

Bidders should note that they are subject to "Safety and Health Regulations for Construction", Chapter XVII of Title 29, CFR, Part 1926 and that compliance, review and enforcement are the responsibility of the U.S. Department of Labor.

The Contractor is fully responsible for the safety of the work site and is expected to train their employees in all applicable safety issues. This should include but not be limited to: trench safety, confined space entry, head protection, etc. In accordance with construction contracts with the City, Authority, Board, or Commission, all applicable Labor and OSHA safety regulations must be followed.

Work sites must be monitored by the Contractor and safety provisions enforced. Contractors are asked to ensure that all employees are properly informed and trained in construction, work site safety.

**B-20 VENDORS AND SUBCONTRACTOR IDENTIFICATION**

Where Vendor and Subcontractor Identification Questionnaires are included in the bid documents, each bidder shall submit the Questionnaire directly to the Engineer no later than 5:00 p.m. on the first working day following the bid opening. Failure to submit the questionnaire may render the bid unresponsive and not eligible for award. The award of the Contract will be subject to the acceptability of the vendors and subcontractors listed. If an award is made, the vendors and subcontractors listed on the questionnaire shall be used on the project. No changes in the vendor and subcontractor list will be permitted unless prior consent is obtained from the Engineer.

**B-21 U.S. ENVIRONMENTAL PROTECTION AGENCY NPDES REQUIREMENTS FOR STORMWATER DISCHARGES**

The bidder's attention is directed to U.S. Environmental Protection Agency (EPA) NPDES requirements for stormwater discharges. The Contractor shall be responsible for filing a Notice of Intent and development and implementation of a Stormwater Pollution Prevention Plan (PPP).

**B-22 AMERICANS WITH DISABILITIES ACT**

The Contractor shall take the necessary actions to ensure its facilities are in compliance with the requirements of the Americans with Disabilities Act (ADA). It is understood that the program of the Contractor is not a program or activity of the Tulsa Metropolitan Utility Authority. The Contractor agrees that its program or activity will comply with the requirements of the ADA. Any costs of such compliance will be the responsibility of the Contractor. Under no circumstances will the Contractor conduct any activity, which it deems non-compliant with the ADA.

## RESOLUTION NO. 18145

A RESOLUTION REQUIRING THE INCLUSION IN PLANS AND SPECIFICATIONS FOR PUBLIC IMPROVEMENT CONTRACTS OF PROVISIONS PROVIDING FOR THE EMPLOYMENT OF BONA FIDE RESIDENTS OF THE CITY OF TULSA; AND/OR THE MSA; ALSO PROVIDING THAT AT LEAST OF FIFTY PERCENT (50%) OF EACH CLASS OF EMPLOYEES USED ON A PROJECT BE BONA FIDE RESIDENTS OF THE CITY OF TULSA AND/OR THE MSA; THAT THE DIRECTOR OF THE DEPARTMENT OF HUMAN RIGHTS IS CHARGED WITH ENSURING THAT ALL BIDS FOR PUBLIC CONSTRUCTION CONTRACTS COMPLY WITH THIS RESOLUTION; AND DECLARING AN EMERGENCY.

WHEREAS, City of Tulsa, Oklahoma, desires to achieve a goal of full employment.

WHEREAS, it is necessary for the protection of the health, safety and welfare of all residents of the City of Tulsa, Oklahoma, to accomplish this goal.

NOW, THEREFORE, BE IT RESOLVED BY THE BOARD OF COMMISSIONERS OF THE CITY OF TULSA, OKLAHOMA:

SECTION 1. The City of Tulsa is committed to the policy of achieving full employment of its citizens by encouraging the employment of bona fide Tulsa and MSA residents in public improvement contracts.

SECTION 2. Definitions. The definitions of certain terms used in this resolution are as follows:

a. "Bidding Documents" or "Bid" means the bid notice, plans and specifications, bidding form, bidding instructions, special provisions and all other written instruments prepared by or on behalf of an awarding public agency for use by prospective bidders on a public construction contract.

b. (i) "Bona Fide Residents" shall include only those persons who are either registered to vote in the City of Tulsa or who have resided within the city limits for at least six months, or who have purchased a permanent residence within the city limits or who have leased a residence for at least a six month term. Residency may be further determined by a valid Oklahoma driver's license, a current Oklahoma license tag, and a valid Oklahoma automobile inspection sticker. (ii) Bona fide residents of MSA shall include only those persons who are registered to vote in outlying MSA areas or who have resided within the outlying MSA area for at least six months, or who have purchased a permanent residence within the outlying MSA areas or who have leased a residence for at least a six month term. Residency may be further determined by a valid Oklahoma driver's license, a current Oklahoma license tag, and a valid Oklahoma automobile inspection sticker.

c. "Public Construction Contract" or "Contract" means any contract exceeding Seven Thousand Five Hundred Dollars (\$7,500.00) in amount, awarded by the City of Tulsa for the purpose of making any public improvements or constructing any public building or making repairs to the same.

d. "Public Improvement" means any beneficial or valuable change or addition, betterment, enhancement or amelioration of or upon any real property, or interest therein, belonging to the City of Tulsa, intended to enhance its value, beauty or utility or to adapt it to new or further purposes. The term does not include the direct purchase of materials, equipment or supplies by the City of Tulsa.

CITY OF TULSA  
FILED

AUG 23 1988

Office Of City Auditor

e. "MSA". All of the land areas composed of Creek County, Osage County, Rogers County, Tulsa County and Wagoner County.

SECTION 3. Residency Requirements of Contractor's Employees. Every employee and/or agent of the City of Tulsa, Oklahoma, charged or involved with the preparation of plans and specifications for any public impvment funded in whole or in part with funds of the City of Tulsa, is hereby charged to include in said plans and specifications the following provisions which shall be binding upon the successful bidders:

- a. Each bid shall be accompanied by a sworn statement that the bidder is committed to the goal of employing at least 50% bona fide residents of the City of Tulsa and/or the MSA in each classification as determined by the Oklahoma Commissioner of Labor.
- b. The successful bidder will be responsible for having like requirements placed upon any subcontractor.
- c. The successful bidder will submit to the Director or his designated representative of the Department of Human Rights any compliance reports involving the bidder and its subcontractors required by Title 31, Chapter 1, Section 9, of the Tulsa Revised Ordinances. The reports shall include information about the residence of each employee in each laboring and trade class applicable to any City project.

SECTION 4. Unresponsive Bids. The failure to submit the documents required by Section 3 shall render a bid unresponsive. Said documents must be submitted prior to the opening of the bids. The Director of the Department of Human Rights Section of City Development is charged with ensuring that all bids comply with Section 3 prior to the bid opening date.

SECTION 5. Duty of Employees and/or Agents of the City of Tulsa. Any employee and/or agent of the City of Tulsa who fails to include the goals for residency requirements found in Section 3 in the plans and specifications for any public improvement may be subject to disciplinary action, including dismissal.

SECTION 6. Severability. The invalidity of any section, subsection, provision or clause or portion of this chapter, or the invalidity of the application thereof to any person or circumstance shall not affect the validity of the remainder of this chapter or the validity of its application to other persons or circumstances.

SECTION 7. Effect Date. This resolution shall take effect as of July 1, 1988.

SECTION 8. Emergency Clause. That an emergency exists for the preservation of the public peace, health and safety, by reason whereof this resolution shall take effect immediately upon its passage, approval and publication.

PASSED, with the emergency clause ruled upon separately and approved this 23<sup>rd</sup> day of August, 1988.

APPROVED, this 23<sup>rd</sup> day of August, 1988.

Rodger Randle

*[Handwritten signature]*

Mayor

ATTEST: Philip W. Wood

*[Handwritten signature: Philip W. Wood]*

City Auditor

APPROVED: Neal E. McNeil

*[Handwritten signature: Neal E. McNeil]*

City Attorney

PASSED, with the emergency clause ruled upon separately and approved this 23 day of August, 1988.

- APPROVED, this 23 day of August, 1988.

*[Handwritten signature]*

Mayor

ATTEST:

*[Handwritten signature: Philip W. Wood]*

City Auditor

APPROVED:

*[Handwritten signature: Neal E. McNeil]*

City Attorney

CITY OF TOLEDO  
FILED

AUG 23 1988

A.M. P.M.  
Office Of City Auditor  
By \_\_\_\_\_

(Must be submitted at time of Bid)  
CITY OF TULSA  
RESOLUTION NO. 7404  
AFFIDAVIT OF COMPLIANCE

\_\_\_\_\_, of lawful age, being first duly sworn, states that s(he) is the authorized agent of the Company set forth below.

Affiant further states that the Company, in compliance with City of Tulsa Resolution No. 7404, shall not hire or knowingly allow any of its subcontractors or lower tier subcontractors to hire anyone who is not a United States citizen or legal immigrant or anyone who does not have legal status as a temporary worker to perform work on any project which is the subject of a contract between the Company and the City of Tulsa.

Affiant further states that the Company shall not fail to comply with and shall not knowingly allow any of its subcontractors or lower tier subcontractors to fail to comply with all applicable laws including, but not limited to, labor, employment and taxation laws, in the performance of any work on any project which is the subject of a contract between the Company and the City of Tulsa.

Affiant further states that the Company shall make available to the City of Tulsa, at the City's request, sufficient information and/or affirmations to allow the City to confirm Company's compliance with Resolution No. 7404 relating to the performance of any contract between the Company and the City of Tulsa.

Company: \_\_\_\_\_

Signed: \_\_\_\_\_

\_\_\_\_\_  
Title

SUBSCRIBED and SWORN to before me, this \_\_\_\_ day of \_\_\_\_\_, 20\_\_.

\_\_\_\_\_  
NOTARY PUBLIC

MY COMMISSION EXPIRES:

\_\_\_\_\_

COMMISSION NO.:

\_\_\_\_\_

Resolution No. 7404  
RAC-1

(Must be submitted at time of Bid)  
CITY OF TULSA  
50% RESIDENT RESOLUTION  
AFFIDAVIT FOR BID

STATE OF \_\_\_\_\_ )  
 ) ss:  
COUNTY OF \_\_\_\_\_ )

\_\_\_\_\_, of lawful age, being first duly sworn, states that s(he) is the agent authorized by the bidder to submit the attached bid. Affiant further states that the bidder, in compliance with City of Tulsa Resolution No. 18145, is committed to the goal of employing at least 50% bona fide residents of the City of Tulsa and/or the Metropolitan Statistical Area (composed of Creek, Okmulgee, Osage, Pawnee, Rogers, Tulsa, and Wagoner counties).

Affiant further states that bidder is responsible for having like requirements placed upon any of its subcontractors.

\_\_\_\_\_  
**BIDDER (Company Name)**

\_\_\_\_\_  
**SIGNED**  
\_\_\_\_\_  
**Title**

SUBSCRIBED and SWORN to before me this \_\_\_\_ day of \_\_\_\_\_, 20\_\_\_\_.

\_\_\_\_\_  
**NOTARY PUBLIC**

MY COMISSION EXPIRES:

\_\_\_\_\_

COMMISSION NO.:

\_\_\_\_\_

(Must be submitted at time of bid)  
**NON-COLLUSION AFFIDAVIT**

STATE OF \_\_\_\_\_ )  
 ) ss:  
COUNTY OF \_\_\_\_\_ )

\_\_\_\_\_, of lawful age, being first duly sworn, says that:

1. I am the duly authorized agent of the bidder submitting the competitive bid associated with this sworn statement for the purpose of certifying facts pertaining to the existence of collusion among bidders and between bidders and municipal officers or employees, as well as facts pertaining to the giving or offering of things of value to governmental personnel in return for special consideration in the letting of any contract pursuant to the bid;
2. I am fully aware of the facts and circumstances surrounding the making of the bid and have been personally and directly involved in the proceedings leading to the submission of such bid;
3. Neither the bidder nor anyone subject to the bidder's direction or control has been a party:
  - a. to any collusion among bidders in restraint of freedom of competition by agreement to bid at a fixed price or to refrain from bidding;
  - b. to any collusion with any municipal official or employee as to quantity, quality or price in the prospective contract, or as to any other terms of such prospective contract; nor
  - c. in any discussions between bidders and any municipal official concerning exchange of money or other things of value for special consideration in the letting of a contract.
4. If awarded the contract, neither the bidder nor anyone subject to the bidder's direction or control has paid, given or donated or agreed to pay, give or donate to any officer or employee of the City of Tulsa or of any public trust where the City of Tulsa is a beneficiary, any money or other thing of value, either directly or indirectly, in procuring the contract for which the bid is submitted.

\_\_\_\_\_  
BIDDER (Company Name)

\_\_\_\_\_  
Signed

\_\_\_\_\_  
Title

SUBSCRIBED and SWORN to before me this \_\_\_\_\_ day of \_\_\_\_\_, 20\_\_.

\_\_\_\_\_  
NOTARY PUBLIC

MY COMMISSION EXPIRES:

\_\_\_\_\_, \_\_\_\_\_.  
COMMISSION NO.:

(Must be submitted at time of bid)  
**BUSINESS RELATIONSHIP AFFIDAVIT**

STATE OF )  
 ) ss:  
COUNTY OF )

\_\_\_\_\_, of lawful age, being first duly sworn, says that s(he) is the agent authorized by the bidder to submit the attached bid. Affiant further states that the nature of any partnership, joint venture or other business relationship presently in effect or which existed within one (1) year prior to the date of this statement with the architect, engineer, or other party to the project is as follows:

\_\_\_\_\_  
\_\_\_\_\_  
\_\_\_\_\_

Affiant further states that any such business relationship presently in effect or which existed within one (1) year prior to the date of this statement between any officer or director of the bidding company and any officer or director of the architectural or engineering firm or other party to the project is as follows:

\_\_\_\_\_  
\_\_\_\_\_  
\_\_\_\_\_

Affiant further states that the names of all persons having any such business relationships and the positions they hold with their respective companies or firms are as follows:

\_\_\_\_\_  
\_\_\_\_\_  
\_\_\_\_\_

(If none of the business relationships herein above mentioned exist, affiant should so state.)

Signed: \_\_\_\_\_

\_\_\_\_\_  
BIDDER (Company Name)

\_\_\_\_\_  
Title:

SUBSCRIBED and SWORN to before me this \_\_\_\_\_ day of \_\_\_\_\_, 20\_\_.

\_\_\_\_\_  
NOTARY PUBLIC

MY COMMISSION EXPIRES:

\_\_\_\_\_, \_\_\_\_\_  
COMMISSION NO.:

\_\_\_\_\_



## ELECTRONIC BID PROPOSAL INSTRUCTIONS - EXCEL SPREADSHEET

PROJECT NO. ES 2022-09

SPUNKY CREEK INTERCEPTOR MAIN STEM SOUTH, PHASE 3

### Please read the following instructions carefully.

1. After opening this file re-save it as your company's name.
2. Open the BID FORM Sheet from the tabs below.
3. Input the unit price of the appropriate pay item in the cells highlighted in blue.
4. Review all data input and check calculations to ensure accuracy of Bid.
5. Print 1hardcopy of the "PROPOSAL" tab, BID FORM and the "SIGNATURE PAGE" tab.
6. Complete and sign the "Signature Page" document.
6. Submit hardcopy and electronic disk with Contract Documents and Specifications for Bid opening date.

### LEGEND

- \$ 1.00 Cells Requiring Data Input.
- \$ 1.00 Internal Data Transfer.
- \$ 2.00 Calculated Results.

### AGREEMENT FOR USING ELECTRONIC BID PROPOSAL

By and Between: RJN Group, Inc., (ENGINEER) and RECIPIENT. The enclosed electronic media is provided pursuant to your request and is for your limited use in connection with your submittal of Bid Proposal for TMUA Project No. ES 2022-09. In no event shall the information be used for any other purpose or be released to third parties without the written consent of the ENGINEER. In the event of a discrepancy between the hard copy and this electronic media at delivery or in the future, the hard copy shall govern. ENGINEER hereby disclaims any and all liability for the consequences from use of the electronic media and makes no warranty or guarantee of accuracy. RECIPIENT shall assume full responsibility for the uses and consequences of the electronic media. It is agreed that ENGINEER has and retains ownership of the electronic media. ENGINEER does not warrant or guarantee that the electronic data is compatible with RECIPIENT'S computer hardware or software, and ENGINEER'S responsibility for the electronic media is limited to replacement of defective media for a period of thirty (30) days after delivery to RECIPIENT. !!! By opening and using this FILE, You AGREE to these TERMS AND CONDITIONS!!!

**PROPOSAL FOR  
SPUNKY CREEK INTERCEPTOR MAIN STEM SOUTH, PHASE 3  
TMUA PROJECT NO. ES 2022-09**

TO: TULSA METROPOLITAN UTILITY AUTHORITY  
CITY OF TULSA, OKLAHOMA

THE UNDERSIGNED BIDDER, having carefully examined the drawings, specifications, and other Contract Documents of the above project presently on file in the City Clerk, City of Tulsa Oklahoma:

CERTIFIES THAT he has inspected the site of the proposed work and has full knowledge of the extent and character of the work involved, construction difficulties that may be encountered, and materials necessary for construction, class and type of excavation, and all other factors affecting or which may be affected by the specified work; and

CERTIFIES THAT he has not entered into collusion with any other bidder or prospective bidder relative to the project and/or bid: and

HEREBY PROPOSES: to enter into a contract to provide all necessary labor, materials, equipment and tools to completely construct and finish all the work required by the Contract Documents hereto attached and other documents referred to therein: to complete said work within **365** calendar days after the work order is issued; and to accept in full payment therefore the amount set forth below for all work actually performed as computed by the Engineer as set forth in the Contract.

**Basis of Award**

IT SHOULD BE NOTED THAT THE LOWEST RESPONSIVE BID SHALL BE DETERMINED BY THE TOTAL BASE BID PLUS ADDITIVE ALTERNATES NO. 1. THE ITEMS IN ADDITIVE ALTERNATES NO. 1 MAY OR MAY NOT BE INCLUDED IN THE CONTRACT AWARD AT THE SOLE DISCRETION OF THE CITY OF TULSA. ANY PROPOSAL SUBMITTED WITH THE ADDITIVE ALTERNATE NO. 1 INCOMPLETE SHALL BE CONSIDERED NON-RESPONSIVE

**Note:** - Item numbers omitted are not a part of the Contract.

PROPOSAL FOR  
SPUNKY CREEK INTERCEPTOR MAIN STEM SOUTH, PHASE 3  
TMUA ES 2022-09

BASE BID						
BID ITEM	SPEC NO.	DESCRIPTION	UNIT	QTY	DATA INPUT UNIT PRICE	TOTAL EACH ITEM
1	102	PROJECT SIGN (CITY OF TULSA)	EA	2		
2	301, SP-8	RIGHT-OF-WAY CLEARING AND RESTORING	SY	33,120		
3	302	UNCLASSIFIED EXCAVATION AND BACKFILL	CY	16,250		
4	303	MOBILIZATION	EA	1		
5	304	CONTRACTOR CONSTRUCTION STAKING	EA	1		
6	309	8-INCH DIAMETER CLASS 51 DIP (RJ) BY OPEN CUT	LF	15		
7	309	12-INCH DIAMETER CLASS 51 DIP BY OPEN CUT	LF	199		
8	309	12-INCH DIAMETER CLASS 51 DIP (RJ) BY OPEN CUT	LF	229		
9	309	12-INCH DIAMETER CLASS 51 DIP (RJ) IN 24-INCH DIAMETER STEEL CASING	LF	175		
10	312	8-INCH DIAMETER DIP 22.5 DEGREE BEND (RJ)	EA	2		
11	312	12-INCH DIAMETER DIP 22.5 DEGREE BEND (RJ)	EA	4		
12	312	12-INCH X 12-INCH X 6-INCH DIP TEE FITTING (RJ)	EA	1		
13	312	12-INCH X 12-INCH X 8-INCH DIP TEE FITTING (RJ)	EA	1		
14	313, SP-1,2,7	18-INCH DIAMETER PS 75 ASTM D3034 PVC OR SN 72 FRP SEWER BY OPEN CUT	LF	1,543		
15	313, SP-1,2,7	18-INCH DIAMETER PS 75 ASTM D3034 OR SN 72 FRP (RJ) SEWER IN 36-INCH DIAMETER STEEL CASING	LF	110		
16	313, SP-1,2,7	24-INCH DIAMETER PS 75 ASTM D3034 PVC OR SN 72 FRP SEWER BY OPEN CUT	LF	4,307		
17	314, SP-3,4,5,6	CONSTRUCT STANDARD 5-FOOT DIAMETER MANHOLE OR TEE BASE MANHOLE (0-6 FEET)	EA	3		
18	314, SP-3,4,5,6	EXTRA DEPTH OVER 6 FEET FOR STANDARD 5-FOOT DIAMETER MANHOLE OR TEE BASE MANHOLE	VF	31.3		
19	314, SP-3,4,5,6	CONSTRUCT STANDARD 6-FOOT DIAMETER MANHOLE OR TEE BASE MANHOLE (0-6 FEET)	EA	10		
20	314, SP-3,4,5,6	EXTRA DEPTH OVER 6 FEET FOR STANDARD 6-FOOT DIAMETER MANHOLE OR TEE BASE MANHOLE	VF	142.9		
21	314, SP-3,4,5,6	CONSTRUCT STANDARD 6-FOOT DIAMETER DROP MANHOLE OR TEE BASE MANHOLE (0-6 FEET)	EA	2		
22	314, SP-3,4,5,6	EXTRA DEPTH OVER 6 FEET FOR STANDARD 6-FOOT DIAMETER DROP MANHOLE OR TEE BASE MANHOLE	VF	34.7		
23	315	CONNECT TO EXISTING MANHOLE	EA	2		
24	315	CONNECT TO EXISTING WATERLINE	EA	3		
25	317	8-INCH DIAMETER GATE VALVE (RJ)	EA	1		
26	317	12-INCH DIAMETER GATE VALVE (RJ)	EA	2		
27	319	INSTALL FLOWABLE FILL	CY	20		
28	322	24-INCH DIAMETER STEEL CASING INSTALLED BY BORE AND JACK	LF	175		
29	322	36-INCH DIAMETER STEEL CASING INSTALLED BY BORE AND JACK	LF	110		
30	325	HYDROMULCH SEEDING	SY	5,500		
31	327	SAFETY FENCE	LF	400		
32	329	REMOVE AND REPLACE CONCRETE SIDEWALK	SY	187		
33	329	REMOVE AND REPLACE ASPHALT DRIVEWAY	SY	36		
34	329	REMOVE AND REPLACE ASPHALT PAVEMENT	SY	374		
35	331	WATER TABLE CRADLE FOR 18-INCH DIAMETER PIPE	LF	250		
36	331	WATER TABLE CRADLE FOR 24-INCH DIAMETER PIPE	LF	500		
37	333	CUT AND PLUG EX. SANITARY SEWER	EA	2		
38	333	ABANDON EXISTING 12-INCH SANITARY SEWER FORCE MAIN	LF	5,717		
39	333	ABANDON EXISTING SANITARY SEWER ARV MANHOLES	EA	3		
40	333, SP-15	STONE CREEK FARMS LIFT STATION DEMOLITION AND ABANDONMENT	LS	1		
41	334	CONSTRUCTION AS-BUILTS	LS	1		
42	335	ACCEPTANCE SAMPLING/TESTING REQUIREMENTS	LS	1		
43	418	REPLACEMENT OF COVER, FRAME, FRAME SEAL - TYPE A REPAIR	EA	1		
44	SP-13	STEEL FRAME GATE	EA	8		
45	ODOT 202 (H)	EARTHWORK	LS	1		
46	ODOT 220, SP-17	SWPPP DOCUMENTATION AND MANAGEMENT	LS	1		
47	ODOT 880 (J)	CONSTRUCTION TRAFFIC CONTROL	CD	365		
48	SPECIAL	OWNERS ALLOWANCE	ALLOW	100,000	\$1 00	\$100,000.00
					BASE BID TOTAL	\$100,000.00
ADDITIVE ALTERNATE NO. 1						
BID ITEM	SPEC NO.	DESCRIPTION	UNIT	QTY	DATA INPUT UNIT PRICE	TOTAL EACH ITEM
49	ODOT 209	MACHINE GRADING FOR GRAVEL ACCESS ROAD	LF	5,510		\$ -
50	ODOT 213	GRADED ROCK (SIZE #1)	CY	1,910		\$ -
51	ODOT 213	CRUSHED STONE (SIZE #7)	CY	890		\$ -
52	ODOT 712, SP-14	CLASS IV GEOTEXTILE	SY	9,600		\$ -
53	ODOT 613 (EE), SP-12	18-INCH DIAMETER CORRUGATED POLYPROPYLENE STORM PIPE	LF	300		\$ -
54	ODOT 613 (M), SP-12	CULVERT END TREATMENT SINGLE PIPE	EA	4		\$ -
55	ODOT 613 (M), SP-12	CULVERT END TREATMENT DOUBLE PIPE	EA	12		\$ -
56	SP-16	CABLE REINFORCED CONCRETE BLOCK MAT	SY	306		\$ -
					ADDITIVE ALTERNATE NO. 1 TOTAL	\$ -
					BASE BID + ADDITIVE ALTERNATE NO. 1 TOTAL	\$ 100,000.00

BASE BID (ITEMS 1-48)  
ADDITIVE ALTERNATE NO. 1 (ITEMS 49-56)  
BASE BID PLUS ADDITIVE ALTERNATE

\$100,000.00  
\$0.00  
\$100,000.00

Enclosed is a ( ) Bidder's Surety Bond, ( ) Certified Check, ( ) Cashier's Check for \_\_\_\_\_ %

which the City of Tulsa may retain or recover as liquidated damages in the event that the undersigned fails to enter into contract for the work covered by this proposal., provided the Contract is awarded to the undersigned within thirty (30) days, or within ninety (90) days if Federal funds are utilized, from the date fixed for opening of bids and the undersigned fails to execute said Contract and furnish the required bonds and other requirements as called for in these Contract Documents within thirty (30) days after award of Contract.

Dated at Tulsa, Oklahoma, this \_\_\_\_\_ day of \_\_\_\_\_, 20\_\_.

Respectfully submitted,

\_\_\_\_\_  
(Complete legal name of company)

\_\_\_\_\_  
(State of Organization)

By: \_\_\_\_\_  
Title: \_\_\_\_\_  
Printed Name: \_\_\_\_\_

ATTEST: \_\_\_\_\_  
Title: Corporate Secretary  
Printed Name: \_\_\_\_\_

(SEAL)

Address: \_\_\_\_\_  
\_\_\_\_\_  
\_\_\_\_\_  
\_\_\_\_\_

Telephone Number: \_\_\_\_\_

Fax Number: \_\_\_\_\_

By signing above the bidder acknowledges receipt of the following Addenda (give number and date of each):

\_\_\_\_\_  
\_\_\_\_\_  
\_\_\_\_\_  
\_\_\_\_\_

This form is made available for example purposes only and is not intended to be legal advice nor intended to be relied upon in lieu of consultation with an attorney.

### Certificate of Secretary

The undersigned \_\_\_\_\_ (Assistant) Secretary of \_\_\_\_\_, a \_\_\_\_\_ corporation, (the "Corporation") hereby certifies that the following is a true and correct copy of a Resolution duly adopted by the Board of Directors of the Corporation on the \_\_\_\_ day of \_\_\_\_\_, 20\_\_.

RESOLVED, that \_\_\_\_\_ is authorized to execute and enter into bids, contracts, bonds, affidavits and any ancillary documents, on behalf of the Corporation.

The undersigned further certifies that this Resolution is in full force and effect as of the date of this Certificate and has not been amended, modified, revoked or rescinded.

IN WITNESS WHEREOF, I have executed this Certificate this \_\_\_\_ day of \_\_\_\_\_, 20\_\_.

\_\_\_\_\_  
(Signature)

\_\_\_\_\_  
Printed Name

\_\_\_\_\_  
(Assistant) Secretary

This form is made available for example purposes only and is not intended to be legal advice nor intended to be relied upon in lieu of consultation with an attorney.

### Consent of Members

The undersigned, being all of the Members of [Name of Company], LLC, an Oklahoma Limited Liability Company, hereby authorize, consent to, approve and ratify the execution by \_\_\_\_\_ on behalf of [Name of Company], LLC of bid proposals, contracts, affidavits and related documents in connection with [Name of Project] of the City of Tulsa.

DATED, this \_\_\_\_ day of \_\_\_\_\_, 20\_\_.

\_\_\_\_\_

Name printed: \_\_\_\_\_

\_\_\_\_\_

Name Printed: \_\_\_\_\_

[ADD ADDITIONAL LINES FOR ADDITIONAL MEMBERS]



**TMUA: Tulsa Metropolitan  
Utility Authority**

---

(DATE)

(Company Name)

(Address)

(City, State, Zip Code)

RE: Tulsa Metropolitan Utility Authority Project No.

TO WHOM IT MAY CONCERN:

The vendor of materials and supplies under the above referenced contract is hereby authorized to invoice the Tulsa Metropolitan Utility Authority (TMUA), 175 E. 2<sup>nd</sup> Street, Suite 1300, Tulsa, Oklahoma 74107, for all materials and supplies purchased under the above contract, noting any contract discount and omitting all sales taxes. All invoices shall include the contract number and the name of the contractor ordering the materials or supplies.

Upon receipt the Tulsa Metropolitan Utility Authority will pay the invoice, in accordance with its terms and conditions, as money is due the Contractor per referenced contract.

This letter of authorization expires Date.

Sincerely,

Eric Lee,  
Director of Water and Sewer

MV:cc

**EXTENSION OF TIME REQUEST**  
(to be submitted with each partial payment application)

DATE: \_\_\_\_\_

CONTRACTOR: \_\_\_\_\_

ADDRESS: \_\_\_\_\_

\_\_\_\_\_

CONTRACT NO.: \_\_\_\_\_

PROJECT NO.: \_\_\_\_\_

DESCRIPTION: \_\_\_\_\_

ARE THERE ANY CHANGES TO YOUR SBE UTILIZATION?     YES                       NO

IF YES, GIVE REASON AND ATTACH CHANGE REQUEST FORM (SBE-4): \_\_\_\_\_

\_\_\_\_\_

EXTENSION OF CONTRACT TIME REQUIRED:  YES                       NO

TOTAL OF EXTENSION TIME REQUESTED: \_\_\_\_\_

IF YES GIVE REASON: \_\_\_\_\_

\_\_\_\_\_

\_\_\_\_\_

\_\_\_\_\_  
SIGNATURE - CONTRACTOR

\_\_\_\_\_  
CONSULTING ENGINEER OR DEPARTMENT OF PUBLIC WORKS STAFF RECOMMENDATIONS

APPROVED: \_\_\_\_\_

REJECTED: \_\_\_\_\_

REASON: \_\_\_\_\_

\_\_\_\_\_

\_\_\_\_\_

\_\_\_\_\_

\_\_\_\_\_  
SIGNATURE

\_\_\_\_\_  
DATE

ACTION WILL BE TAKEN WITHIN 30 DAYS FROM RECEIPT OF REQUEST

ETR-1

## CONTRACT FOR CONSTRUCTION OF PUBLIC IMPROVEMENTS

### TULSA, OKLAHOMA

**THIS CONTRACT** made and entered into this \_\_\_\_\_ day of \_\_\_\_\_, 2026, by and between \_\_, an (list state)\_\_\_\_\_ (Corporation or Limited Liability Company) of \_\_, Oklahoma hereinafter called the "CONTRACTOR", and the TULSA METROPOLITAN UTILITY AUTHORITY, Tulsa, Oklahoma, a Public Trust, herein called the "Authority".

#### **WITNESSETH:**

**WHEREAS**, the Authority has caused to be prepared the necessary Drawings, Specifications, and other Contract Documents for the public improvements herein described, and has invited bids for the construction thereof in accordance with the terms of the Contract, all of which is hereby designated as:

#### **PROJECT NO. ES 2022-09 SPUNKY CREEK INTERCEPTOR MAIN STEM SOUTH PHASE 3**

**WHEREAS**, the Contractor, in response to the Advertisement, has submitted to the Authority, in the manner and at the time specified, a sealed bid in accordance with the terms of this Contract; and,

**WHEREAS**, the Authority, in the manner prescribed by law, has publicly opened, examined, and canvassed the bids submitted, and has determined the above named Contractor to be the lowest responsible bidder for the work and has duly awarded to the said Contractor therefore, for the sum or sums named in the Contractor's bid, a copy of the Bid Form being attached to and made a part of this Contract;

**NOW, THEREFORE**, in consideration of the compensation to be paid to the Contractor and of the mutual agreements and covenants herein contained, the parties to this Contract have agreed and hereby agree, as follows:

**ARTICLE I.** That the contractor shall (a) furnish all tools, equipment, supplies, superintendence, transportation, and other construction accessories, services, and facilities; (b) furnish all materials, supplies, and equipment specified and required to be incorporated in and form a permanent part of the completed work; (c) provide and perform all necessary labor; and (d) in a good, substantial, and workmanlike manner and in accordance with the requirements, stipulations, provisions and conditions of the Contract as defined in the attached General Conditions, said documents forming the Contract and being as fully a part thereof as if repeated verbatim herein, perform, execute, construct, and complete all work included in and covered by the Authority's official award of this Contract to the said Contractor, such award being based on the acceptance by the Authority of the Contractor's bid, or part thereof, as follows:

**PROJECT NO. ES 2022-09 SPUNKY CREEK INTERCEPTOR MAIN STEM SOUTH PHASE 3**

**ARTICLE II.** That the Authority shall pay to the Contractor for performance of the work embraced in this Contract, and the Contractor will accept as full compensation therefor, the sum (subject to adjustment as provided by the Contract) of AND /100 Dollars (\$\_\_\_\_\_ ) for all work covered by and included in the Contract award and designated in the foregoing Article I; payments therefore to be made in cash or its equivalent, in the manner provided in the General Conditions.

**ARTICLE IIA.** All materials and supplies to be purchased under the terms of this contract shall be ordered by the Contractor from the vendor or supplier who shall be directed to invoice the Tulsa Metropolitan Utility Authority direct. The invoice shall reflect any contractor discount and no sales tax shall be added. The invoice will be paid direct by the Tulsa Metropolitan Utility Authority in accordance with the terms and conditions of the invoice (Oklahoma Tax Commission Rules Part 27 Trust Authority 710:65-13-140). The monies paid direct by Tulsa Metropolitan Utility Authority to the vendor or supplier shall be deducted from the total contract price. The Contractor shall accept delivery and be responsible for and shall warrant and hold the Authority harmless for the safety and security of all of the materials and supplies furnished for the project under this contract.

**ARTICLE III.** That the Contractor shall start work within ten (10) days following the date stipulated in a written order from the Authority to proceed with the work to be performed hereunder, and shall complete the work within the number of consecutive calendar days after the authorized starting date, as stipulated below:

All Work Completed: **365** calendar days

**ARTICLE IV.** The sworn, notarized statement below shall be signed and notarized before this Contract will become effective.

**ARTICLE V.** Prior to submitting a final payment request, the Contractor shall furnish a lien waiver certifying that all subcontractors and suppliers have been paid.

**ARTICLE VI.** If the Contractor has 10 or more full-time employees, and this contract exceeds \$100,000 in total value, Contractor acknowledges and agrees that, in accordance with and pursuant to 21 O.S. 1289.31, Contractor verifies to Authority that: (i) it does not have a practice, policy, guidance, or directive that discriminates against a firearm entity or firearm trade association, and (ii) will not discriminate against a firearm entity or firearm trade association during the term of this Contract.

**IN WITNESS WHEREOF,** the Authority and the Contractor hereto have set their hands and





## City of Tulsa Construction Escalation Process

Step	Contractor Representative(s)	City of Tulsa Representative(s)	Process	Communication / Documentation	Resolution (**)	No Resolution	Typical Time Frame (***)
1.0	Superintendent	Construction Inspector	Field Meeting Request for Information (RFI) may apply	Phone, Text, Email, or RFI / Daily Report	Within Construction Documents	If not resolved within Construction Documents, escalate to 2.0	Same day to 3 days
2.0	Superintendent	Construction Inspector Manager / Construction Inspector	Field Meeting Request for Information (RFI) may apply	Phone, Text, Email, or RFI / Daily Report	Within Construction Documents	If not resolved within Construction Documents, escalate to 3.0	1 day to 3 days
3.0	Project Manager / Superintendent	Construction Manager / Construction Inspector Manager / Construction Inspector Lead Engineer / Project Manager Design Consultant	Contractor submit RFI	Phone, Email, RFI / Daily Report, RFI Log, Progress Mtg	Additional information provided. Potential Allowance Authorization, Extension of Quantities, Change Order, or Other	If not resolved by additional information and within terms of contract, escalate to 4.0	Within 10 calendar days (as ODOT 104.06.B)
4.0	Project Manager / Superintendent	Field Engineering Manager / Construction Manager Lead Engineer / Project Manager Design Consultant	Appeal Construction Manager's Decision	Email, RFI / Daily Report, RFI Log, Progress Mtg	Field Engineering Manager makes determination on appeal. Potential Allowance Authorization, Extension of Quantities, Change Order, or Other	If not resolved by additional information and within terms of contract, escalate to 5.0	Within 10 calendar days (as ODOT 104.06.B)
5.0	Owner / Project Manager / Superintendent	PW Deputy Director and/or other Dept Design Manager / Field Engineering Manager / Construction Manager Lead Engineer / Project Manager Design Consultant	Appeal Field Engineering Manager's Decision	Email, RFI / Daily Report, RFI Log, Progress Mtg	PW Deputy Director and/or other Dept. Design Manager makes determination on appeal. Potential Allowance Authorization, Extension of Quantities, Change Order, or Other	If appeal is not resolved, escalate to 6.0	Within 10 calendar days (as ODOT 104.06.B)
6.0	Owner / Project Manager / Superintendent	Director (*) / PW Deputy Director and/or other Dept Design Manager / Field Engineering Manager / Construction Manager Lead Engineer / Project Manager Design Consultant	Appeal PW Deputy Director's and/or other Dept. Design Manager's Decision	Email, RFI / Daily Report, RFI Log, Progress Mtg	Director makes determination on appeal. Potential Allowance Authorization, Extension of Quantities, Change Order, or Other		Within 10 calendar days (as ODOT 104.06.B)

(\*) Director of the Department under whose authority construction is managed by Public Works Field Engineering. Public Works Deputy Director will notify Director of Public Works.

(\*\*) Resolution - Complete information will assist in the most timely resolution. Each escalation step should address any information deficiencies and proposed resolutions, if any, that were unsatisfactory.

(\*\*\*) Time frames - It is understood that special issues will require a more rapid response and escalation.

PERFORMANCE BOND

KNOW ALL MEN BY THESE PRESENTS: That we, the undersigned, \_\_\_\_\_, (hereinafter called the "Contractor"), duly authorized by law to do business as a construction contractor in the State of Oklahoma, and \_\_\_\_\_ (hereinafter called the "Surety"), a corporation organized under the laws of the State of \_\_\_\_\_, and authorized to transact business in the State of Oklahoma, as Surety, are hereby held and firmly bound unto the Tulsa Metropolitan Utility Authority, Tulsa, Oklahoma (hereinafter called the "Authority"), in the penal sum of Dollars **(full amount of the Contract), (\$00)** lawful money of the United States, for the payment of which, well and truly to be made unto the said Authority, we bind ourselves, our heirs, executors, administrators, successors, and assigns, jointly and severally, firmly by these presents, as follows:

THE CONDITION OF THE FOREGOING OBLIGATION IS SUCH THAT, WHEREAS, the Contractor has on the \_\_\_\_\_ day of \_\_\_\_\_, 20\_\_\_\_, entered into a written contract with the Tulsa Metropolitan Utility Authority, Tulsa, Oklahoma, for furnishing all materials, labor, tools, equipment, and transportation necessary for:

**PROJECT NO. ES 2022-09 SPUNKY CREEK INTERCEPTOR MAIN STEM SOUTH PHASE 3**

NOW, THEREFORE, if said Contractor shall well and truly perform and complete said project in accordance with said Contract, Advertisement for Bids, General Conditions, Instructions to Bidders, Bid Form, Plans and Specifications, and related documents, shall comply with all the requirements of the laws of the State of Oklahoma; shall pay as they become due all just claims for work or labor performed and materials furnished in connection with said contract, and shall defend, indemnify and save harmless said Authority against any and all liens, encumbrances, damages, claims, demands, expenses, costs and charges of every kind, including patent infringement claims except as otherwise provided in said specifications and other contract documents, arising out of or in relation to the performance of said work and the provisions of said Contract, then these presents shall be void; otherwise, they shall remain in full force and effect.

This obligation is made for the use of said Authority and also for the use and benefit of all persons who may perform work or labor, or furnish any material in the execution of said Contract, and may be sued on thereby in the name of the Authority.

The Surety, for value received, hereby stipulates and agrees that no change, extension of time, alteration or addition to the terms of the Contract, or to the work to be performed thereunder, or the specifications accompanying same, shall in any way affect its obligation on this bond; and it does hereby waive notice of any such change, extension of time, alteration or addition of the terms of the Contract, or to the work or to the specifications.

IN WITNESS WHEREOF, the said Principal has caused these presents to be executed in its name and its corporate seal to be hereunto affixed by its duly authorized officers, and the said Surety has caused these presents to be executed in its name and its corporate seal to be hereunto affixed by its attorney-in-fact, duly authorized so to do, the day and year first above written.

\_\_\_\_\_  
CONTRACTOR (Principal)

BY: \_\_\_\_\_ ATTEST: ( S E A L )  
\_\_\_\_\_  
Date: \_\_\_\_\_ Date: \_\_\_\_\_  
Title: \_\_\_\_\_ Title: \_\_\_\_\_

\_\_\_\_\_  
Date: \_\_\_\_\_ Date: \_\_\_\_\_  
Attorney-In-Fact Surety ( S E A L )

\*\* This date shall match the date of the notarized certificate on the Power of Attorney  
(Accompany this Bond with Power-Of-Attorney)

APPROVED AS TO FORM:

\_\_\_\_\_  
Date: \_\_\_\_\_  
Attorney for the Tulsa Metropolitan  
Utility Authority

APPROVED AS TO FORM:

\_\_\_\_\_  
Date: \_\_\_\_\_  
City Attorney

\_\_\_\_\_  
Date: \_\_\_\_\_  
City Clerk

STATUTORY BOND

WHEREAS, the undersigned \_\_\_\_\_  
has entered into a certain contract dated the \_\_\_\_\_ day of \_\_\_\_\_, 20\_\_\_\_,  
designated as **Project No. ES 2022-09**, for the construction of certain public  
improvements consisting of **Spunky Creek Interceptor Main Stem South Phase 3**  
to be situated and constructed on and through the property described in said  
Contract, including all of the work mentioned and described in said Contract, and to  
be performed by the undersigned strictly and punctually in accordance with the terms,  
conditions, drawings and specifications thereof, on file in the office of the Tulsa  
Metropolitan Utility Authority.

NOW, THEREFORE, KNOW ALL MEN BY THESE PRESENTS: That  
\_\_\_\_\_, as Principal, and  
\_\_\_\_\_, a Corporation  
organized under the laws of the State of \_\_\_\_\_, and authorized to  
transact business in the State of Oklahoma, as Surety, are held and firmly bound  
unto the State of Oklahoma in the penal sum of  
\_\_\_\_\_

Dollars (Full Amount of Contract) (\$\_\_\_\_\_), lawful money of the United  
States, for the payment of which sum well and truly to be made, we bind ourselves,  
our successors, and assigns, jointly and severally firmly by these presents.

NOW, THEREFORE, if the said Principal shall fail or neglect to pay all indebtedness  
incurred by Principal or sub-contractors of said principal who perform work in the  
performance of such contract, for labor and materials and repairs to and parts for  
equipment used and consumed in the performance of said contract within thirty (30)  
days after the same becomes due and payable, the person, firm or corporation  
entitled thereto may sue and recover on this bond the amount so due and unpaid.

The Surety, for value received, hereby stipulates and agrees that no change,  
extension of time, alteration, or addition to the terms of the contract or to the work to  
be performed thereunder, or the specifications accompanying the same, shall in any  
way affect its obligation on this bond, and it does hereby waive notice of any such  
change, extension of time, alteration, or addition to the terms of the contract or to the  
specifications.

5/30/06

IN WITNESS WHEREOF, the said Principal has caused these presents to be executed in its name and its corporate seal to be hereunto affixed by its duly authorized officers, and the said Surety has caused these presents to be executed in its name and its corporate seal to be hereunto affixed by its attorney-in-fact, duly authorized so to do, the day and year first above written.

\_\_\_\_\_  
CONTRACTOR(Principal)

BY:

ATTEST: ( S E A L )

\_\_\_\_\_  
Date: \_\_\_\_\_  
Title: \_\_\_\_\_

\_\_\_\_\_  
Date: \_\_\_\_\_  
Title: \_\_\_\_\_

\_\_\_\_\_  
Date: \_\_\_\_\_  
Attorney-In-Fact

\_\_\_\_\_  
Date: \_\_\_\_\_  
Surety ( S E A L )

\*\* This date shall match the date of the notarized certificate on the Power of Attorney

(Accompany this Bond with Power-Of-Attorney)

APPROVED AS TO FORM:

\_\_\_\_\_  
Date: \_\_\_\_\_  
Attorney for the Tulsa Metropolitan  
Utility Authority

APPROVED AS TO FORM:

\_\_\_\_\_  
Date: \_\_\_\_\_  
City Attorney

\_\_\_\_\_  
Date: \_\_\_\_\_  
City Clerk

11/18/05

MAINTENANCE BOND

KNOW ALL MEN BY THESE PRESENTS:

That \_\_\_\_\_, as Principal, and \_\_\_\_\_, a corporation organized under the laws of the State of \_\_\_\_\_ and authorized to transact business in the State of Oklahoma, as Surety, are held and firmly bound unto the Tulsa Metropolitan Utility Authority in the Penal Sum of \_\_\_\_\_

\_\_\_\_\_ Dollars (full amount of Contract) ( \$ \_\_\_\_\_ ) in lawful money of the United States of America for the payment of which, well and truly to be made, we bind ourselves and each of us, our heirs executors, administrators, trustees, successors, and assigns, jointly and severally, firmly by these presents.

The condition of this obligation is such that:

WHEREAS, said Principal entered into a written contract with the Tulsa Metropolitan Utility Authority dated \_\_\_\_\_, 20\_\_\_\_, for

**PROJECT NO. ES 2022-09 SPUNKY CREEK INTERCEPTOR MAIN STEM SOUTH PHASE 3**

all in compliance with the drawings and specifications therefore, made a part of said Contract and on file in the office of the Authority, Tulsa, Oklahoma.

NOW, THEREFORE, if said Principal shall pay or cause to be paid to the Tulsa Metropolitan Utility Authority, all damage, loss, and expense which may result by reason of defective materials and/or workmanship in connection with said work, occurring within a period of one (1) year for all projects, from and after acceptance of said project by the Tulsa Metropolitan Utility Authority and if Principal shall pay or cause to be paid all labor and materials, including the prime contractor and all subcontractors; and if principal shall save and hold the Tulsa Metropolitan Utility Authority harmless from all damages, loss, and expense occasioned by or resulting from any failure whatsoever of said Principal, then this obligation shall be null and void, otherwise to be and remain in full force and effect.

It is further expressly agreed and understood by the parties hereto that no changes or alterations in said Contract and no deviations from the plan or mode of procedure herein fixed shall have the effect of releasing the sureties, or any of them, from the obligation of this Bond.

MB-1

TMUA

11/18/05

IN WITNESS WHEREOF, the said Principal has caused these presents to be executed in its name and its corporate seal to be hereunto affixed by its duly authorized officers, and the said Surety has caused these presents to be executed in its name and its corporate seal to be hereunto affixed by its attorney-in-fact, duly authorized so to do, the day and year first above written.

\_\_\_\_\_  
CONTRACTOR(Principal)

BY:	ATTEST: ( S E A L )
_____ Date: _____	_____ Date: _____
Title: _____	Title: _____
_____ Date: _____	_____ Date: _____
Attorney-In-Fact **	Surety ( S E A L )

\*\* This date shall match the date of the notarized certificate on the Power of Attorney  
(Accompany this Bond with Power-Of-Attorney)

APPROVED AS TO FORM:

\_\_\_\_\_ Date: \_\_\_\_\_  
Attorney for the Tulsa Metropolitan  
Utility Authority

APPROVED AS TO FORM:

\_\_\_\_\_ Date: \_\_\_\_\_  
City Attorney

\_\_\_\_\_ Date: \_\_\_\_\_  
City Clerk

**AFFIDAVIT OF CLAIMANT**

STATE OF \_\_\_\_\_

COUNTY OF \_\_\_\_\_

The undersigned, of lawful age, being first duly sworn, on oath says that this contract is true and correct. Affiant further states that the work, services or materials will be completed or supplied in accordance with the contract, plans, specifications, orders or requests furnished the affiant. Affiant further states that (s)he has made no payment directly or indirectly of money or any other thing of value to any elected official, officer or employee of the City of Tulsa or any public trust of which the City is a beneficiary to obtain or procure the contract or purchase order.

By: \_\_\_\_\_

Signature

Name: \_\_\_\_\_

Company: \_\_\_\_\_

Title: \_\_\_\_\_

Subscribed and sworn to before me this \_\_\_\_\_ day of \_\_\_\_\_, 20\_\_\_\_.

\_\_\_\_\_  
Notary Public

My Commission Expires: \_\_\_\_\_

Notary Commission Number: \_\_\_\_\_

GENERAL  
CONDITIONS

## GENERAL CONDITIONS OF CONTRACT

### GC-1. SCOPE:

The Contract stipulations which follow are general in scope and may refer to conditions which will not be encountered in the performance of the work included in this Contract, and which are not applicable thereto. Any requirements, provisions, or other stipulations of these General Conditions which pertain to a nonexistent condition and are not applicable to the work to be performed hereunder, shall have no meaning in the Contract.

The specifications and drawings are intended to supplement, but not necessarily duplicate each other. Together they constitute one (1) complete set of specifications and drawings, so that any work exhibited in the one and not in the other shall be executed just as if it had been set forth in both, in order that the work shall be completed according to the complete design or designs as decided and determined by the Engineer.

Should anything be omitted from the specifications and drawings which is necessary to a clear understanding of the work, or should it appear various instructions are in conflict, then the Contractor shall request written clarification from the Engineer before proceeding with the construction affected by such omissions or discrepancies.

### GC-2. CONTRACT DOCUMENTS:

It is understood and agreed that the Notice to Bidders, Instructions to Bidders, Proposal, Contract, Statutory Bond, Performance Bond, Maintenance Bond, Power of Attorney, Certificates of Insurance, General Conditions, Specifications, Drawings, Addenda and duly authorized Change Orders, together with any and all supplementary drawings furnished by the Engineer as and when required to make clear and to define in greater detail the intent of the contract, drawings, and specifications, other drawings, specifications, and engineering data furnished by the Contractor (when accepted by the Engineer), and instructions furnished by manufacturers of equipment for the installation thereof, are each and all included in this Contract, and the work shall be done in full compliance and accord therewith.

### GC-3. DEFINITIONS:

Any word, phrase, or other expression defined in this paragraph and used in these Contract Documents shall have the meaning herein given:

1. "Contract" or "Contract Documents" shall include all of the documents and drawings mentioned in Paragraph GC-2.
2. "Authority" shall mean the Tulsa Metropolitan Utility Authority, Tulsa County, Oklahoma, a Public Trust.

3. "Contractor" shall mean the entity named and designated in the Contract who has entered into this Contract to perform the work covered thereby, and its, his, or their duly authorized agents and other legal representatives.
4. "Engineer" shall mean the Superintendent of Water Plant or Sewer Plant, or the Architect or Engineers who have been designated, appointed, or employed by the Authority and Superintendent of Water Plant or Sewer Plant for this project, or their duly authorized agents; such agents acting within the scope of the particular duties entrusted to them in each case.
5. "Inspector" shall mean the engineering or technical inspector or inspectors duly authorized by the Engineer, limited in each case to the particular duties entrusted to him or them.
6. "Surety" shall mean any entity that executes, as surety, the Contractor's performance bond, maintenance bond, and statutory bond securing the performance of this Contract.
7. "Drawings" shall mean and include all drawings prepared by the Authority as a basis for proposals; all drawings submitted by the successful bidder with his proposal and by the Contractor to the Authority, when and as accepted by the Engineer, and all drawings submitted by the Authority to the Contractor during the progress of the work as provided herein.
8. "Subcontractor" shall mean a person, firm or corporation to whom any portion of this work has been sublet by the Contractor.
9. "Work" shall mean the task to be performed, necessary for the fulfillment of this Contract.
10. "Unit Price" shall mean the cost per specified unit of measurement of work and/or material.
11. "Lump Sum" shall mean the price of an item of work including all things necessary to complete the item as shown on the drawings and specifications. Such an item is not measured in units but is defined by description.

**GC-4. MODIFICATIONS AND ALTERATIONS:**

In executing the Contract, the Contractor agrees that the Authority shall have the right to make such modifications, changes, and alterations as the Authority may see fit, in the extent or plan of the Work agreed to be done or any part thereof, or in the materials to be used therein, either before or after the beginning of construction thereof, without affecting the validity of the Contract or the liability of the Sureties upon the performance of this Contract or the Statutory Bond.

Where any modification, change, or alteration increases the quantity of Work to be performed and is within the scope of a fair interpretation thereof, such increase shall be paid for according to the quantity of work actually done, either at Unit Prices included in

the Contract, or in the absence of such unit, as extra Work. Modifications and alterations which reduce the quantity of Work to be done shall not constitute a claim for damages or for anticipated profits on Work involved in such reduction.

The Engineer shall determine, on an equitable basis, the amount of credit due the Authority for Work not performed as a result of modifications or alterations authorized hereunder; where the value of the omitted Work is not fixed by Unit Prices in the Contract; allowance to the Contractor for any actual loss incurred in connection with the purchase, delivery, and subsequent disposal of materials and equipment required for use on the Work as actually built; and any other adjustment of the Contract amount where the method to be used in making such adjustment is not clearly defined in the Contract Documents. In this respect, such determination shall be final and binding only when approved by the Superintendent of Water Plant or Sewer Plant.

**GC-5. CPM SCHEDULE AND DRAWINGS TO BE FURNISHED BY CONTRACTOR:**  
**The successful contractor shall furnish a CPM schedule per ODOT 108.03B.** If at any time, in the opinion of the Engineer, proper progress is not being maintained, such changes shall be made in the schedule of operations, which will satisfy the Engineer that the work will be completed within the period stated in the Proposal. Monthly progress meeting will be conducted to maintain coordination between all project entities.

The Contractor shall furnish all shop, fabrication, assembly, foundation, and other drawings required by the specifications; drawings of equipment and devices, offered by the Contractor for review by the Engineer shall be in sufficient detail to show adequately the construction and operation thereof; drawings of essential details of any change in design or construction proposed for consideration of the Engineer, by the Contractor in lieu of the design or arrangement required by the Contract or any item of extra work thereunder. The Contractor shall submit to the Engineer, the required number of each copy of such drawing for the Engineer's review. After review by the Engineer, all such drawings shall become a part of the Contract Documents and the work or equipment shown thereby shall be in conformity therewith unless otherwise required by the Authority.

The Engineer's check and acceptance of drawings submitted by the Contractor will be for, and will cover, only general conformity to the plans and specifications and will not constitute a blanket acceptance of all dimensions, quantities, and details of the material or equipment shown; nor shall such acceptance relieve the Contractor of his responsibility for errors contained in such drawings.

**GC-6. CONTRACTOR'S BUSINESS ADDRESS:**

The business address of the Contractor given in the bid or proposal upon which this Contract is founded is hereby designated as the place to which all notices, letters, and other communications to the Contractor may be mailed or delivered. The delivery at the above named address or depositing in any mailbox regularly maintained by the Post Office, of any notice, letter, or other communication to the Contractor, shall be deemed sufficient service thereof upon the Contractor and the date of said service shall be the date of such delivery or mailing. Such address may be changed at any time by a written

instrument, executed by the Contractor and delivered to the Engineer. Nothing contained herein shall be deemed to preclude or render inoperative the service of any notice, letter, or communication upon the Contractor personally.

**GC-7. CONTRACTOR'S RISK AND RESPONSIBILITY:**

The performance of the Contract and the Work is at the risk of the Contractor until the final acceptance thereof and payment therefor. The Contractor shall take all responsibility of the Work, and shall bear all losses resulting because of the amount or character of the Work, or because the nature of the land in or on which the Work is done is different from what is assumed or expected, or on account of the weather, floods, fire, windstorm, or other actions of the elements, or any cause or causes, whatsoever, for which the Authority is not responsible. If the Work or any part or parts thereof is destroyed or damaged from any of the aforesaid causes, the Contractor, at his own cost or expense, shall restore the same or remedy the damage.

The Contractor shall, in a good and workmanlike manner, perform all Work and furnish all supplies and materials, machinery, equipment, facilities, and means, except as otherwise expressly specified, necessary or proper to perform and complete all Work required by the Contract within the time herein specified, in accordance with the provisions of these Contract Documents and Drawings of the Work covered by this Contract, and any and all supplemental Drawings. The Contractor shall observe, comply with, and be subject to all terms, conditions, requirements and limitations of the Contract, and shall complete the entire Work to the satisfaction of the Engineer and of the Authority.

**GC-8. ASSIGNMENT AND SUBLETTING OF CONTRACT:**

The Contractor shall give his personal attention to the fulfillment of this Contract, and shall not let, assign or transfer it or his right, title, or interest in any part thereof, by attorney or otherwise, or sublet any part of the Work to any other person without the prior consent of the Authority in writing.

Should any Subcontractor fail to perform his Work in a satisfactory manner, his subcontract shall be immediately terminated by the Contractor upon notice from the Authority. The Contractor shall be fully responsible to the Authority for the acts and omissions of his Subcontractor and of persons either directly or indirectly employed by his Subcontractor. Nothing contained in these Contract Documents shall create any contractual relation between any Subcontractor and the Authority.

**GC-9. CONTRACTOR'S REPRESENTATIVES:**

The Contractor shall designate a person on the Work to represent him when absent from the Work site.

**GC-10. CONTRACTOR AND HIS EMPLOYEES:**

The Contractor shall employ competent foremen, experienced mechanics, and others skilled in the several parts of the Work in this Contract and shall promptly discharge any and all incompetent or otherwise unsatisfactory employees. Contractor's employees directly employed to perform the Work shall not be paid less than the prevailing

minimum wage scale.

Necessary sanitary conveniences for the use of employees on the job site, properly secluded from public observation, shall be provided and maintained by the Contractor. The construction and location of the facility and disposal of the contents shall comply with all laws of the City and State, relating to health and sanitation regulations.

**GC-11. CONTRACTOR'S RIGHT OF PROTEST:**

If the Contractor considers any work demanded of him to be outside the requirements of the Contract, or considers any record or ruling of the Engineers to be unfair, he shall, immediately upon such Work being demanded or such record or ruling being made, ask for written instructions or decisions, whereupon he shall proceed without delay to perform the Work or to conform to the record or ruling, and within ten (10) days after the date of receipt of written instructions or decision, he shall file a written protest with the Engineer, stating clearly and in detail the basis of his objections. Except for such protests and objections made of record in the manner herein specified and within the time stated, the records, rulings, or decisions of the Engineer shall be final and conclusive.

**GC-12. INSURANCE AND BONDS:**

The Contractor (and any subcontractors) shall carry and keep in force during this Contract, policies of insurance issued by an insurer authorized to transact business in Oklahoma in minimum amounts as set forth below or as required by the laws of the State of Oklahoma. The Contractor shall also furnish an Owner's Protective Policy in the same amounts naming the Tulsa Metropolitan Utility Authority as the assured, issued by the same insurance company as the Contractor's liability coverage and indemnifying the Authority against any and all actions, claims, judgments or demands arising from injuries of any kind and character sustained by any person or persons because of work performed by the Contractor.

General Liability Insurance with a bodily injury and property damage combined single limit of not less than \$1,000,000.00 for each occurrence.

Employer's Liability and Workmen's Compensation in the amounts as required by law.

The Contractor shall provide proof of such coverage:

- (a) By providing Certificate(s) of Insurance prior to the execution of this contract; and
- (b) By submitting updated Certificate(s) of Insurance with each and every subsequent request for payment. The Certificate(s) should show that the policies are current and should be dated within 30 days of the payment request.

The Contractor shall not cause any required insurance policy to be cancelled or permit it

to lapse. If the Contractor cancels, allows to lapse, fails to renew or in any way fails to keep any required insurance policy in effect, the Authority will suspend all progress and/or final payments for the project until the required insurance is obtained. Further, a Contractor who fails to keep required insurance policies in effect may be deemed by the Authority to be in breach of contract, ineligible to bid on future projects, and/or ineligible to engage in any new contracts.

The Contractor shall execute and furnish a Statutory Bond for the protection of laborers, mechanics, and material men in a sum equal to one hundred percent (100%) of the contract price.

The Contractor shall execute and furnish a Performance Bond in a sum equal to one hundred percent (100%) of the contract price.

The Contractor shall execute and furnish a Maintenance Bond in a sum equal to one hundred percent (100%) of the contract price.

Prior to doing blasting, the Contractor shall furnish a Certificate of Insurance, which shall certify that any damage caused by blasting is within the coverage of the Contractor's liability insurance to the full limits thereof.

All bonds and insurance must be executed by a company licensed to do business in the State of Oklahoma and must be acceptable to the Authority.

#### GC-13. TIME FOR COMPLETION:

For all projects that will impact the public, a public meeting is required before any work is started. The City of Tulsa requires a minimum of 25 days' notice to get the public meeting scheduled and invitations mailed out.

The Work shall commence within ten (10) days from and after the date of a written order from the Authority. The Contractor agrees that the Work shall be performed regularly, diligently, and uninterruptedly at a uniform rate of progress so as to insure completion within the number of days after the day on which the work order is issued. If the Contractor fails to complete all Work within the time specified, then the Contractor agrees to pay the Authority, not as a penalty, but as liquidated damages for such breach of contract, the sum of **Two Thousand Five Hundred Dollars (\$2,500.00)** for each and every calendar day beyond the date on which the work was to be completed. The said amount is fixed and agreed upon because of the impracticability and extreme difficulty of fixing and ascertaining the actual damages the Authority would sustain in such event. It is expressly understood and agreed that the said time for the completion of the Work described herein is a reasonable time for the completion of the same.

The Contractor shall commence work within twenty-four (24) hours of traffic control devices being established at the project location. If the Contractor fails to commence work within twenty-four (24) hours of traffic control devices being established at the

project location, then the Contractor agrees to pay the Authority, not as a penalty, but as liquidated damages the sum of **One Thousand Dollars (\$1,000.00)** per lane for each day of failure to commence work after the specified time set forth. The amount is fixed and agreed upon because of the impracticability and extreme difficulty of fixing and ascertaining the actual damage the Authority would sustain in such event.

The Contractor will be required to provide a full-time, onsite English-speaking superintendent for this Work for direct contact with Authority and coordination of Subcontractors. A working foreman is not acceptable as a work superintendent. The superintendent shall be required to be present at the Work site whenever the Contractor or Subcontractors are performing Work. The superintendent shall be a representative of the Contractor with the authority to make decisions. If the Contractor fails to provide a non-working superintendent on a day when Work is being performed the Contractor agrees to pay the Authority, not as a penalty, but as liquidated damages for such breach of contract, the sum of **One Thousand Dollars (\$1,000.00)** for each and every calendar day it fails to provide a non-working superintendent at the Work site. This amount is fixed and agreed upon because of the impracticability and extreme difficulty of fixing and ascertaining the actual damages the Authority would sustain in such event.

It is further agreed that time is of the essence as to each and every portion of this Contract and the specifications wherein a definite and certain time is fixed for the performance of any act whatsoever; and where under the Contract an allowance of additional time for completion of any Work is made, the new time fixed by such extension shall be of the essence of this Contract.

Failure to complete the Work within the specified time, as set forth in the Contract, may be grounds for disqualification for future consideration for contracts with the Authority.

Final acceptance of the Work is defined as the completion of the Work and the Contractor moving off the project site. No defined or additional Work is needed.

Contract Evaluation forms will be compiled by Authority staff upon completion of Work to provide a record of the Contractor's performance for use in subsequent projects.

#### GC-14. EXTENSIONS OF TIME:

Should the Contractor be delayed in the final completion of the Work by any act or neglect of the Authority or Engineer, or any employee of either, or strikes, injunctions, fire, or other causes outside of and beyond the control of the Contractor and which, in the opinion of the Engineer, could have been neither anticipated nor avoided, then an extension of time sufficient to compensate for the delay, as determined by the Engineer, shall be granted by the Authority, provided, however, that the Contractor shall give the Authority and the Engineer notice in writing of the cause of each delay on the "Extension of Time Request" form enclosed in these documents, and agrees that any such claim shall be fully compensated for by an extension of time to complete performance of the Work.

The Contractor shall submit the "Extension of Time Request" form with each partial

payment application. Failure to submit the Extension of Time Request with a partial payment application shall constitute a complete waiver of any claim for time extension for the period covered by the partial payment.

Extensions of time will not be granted for delays caused by unsuitable ground conditions, inadequate construction force, or the failure of the Contractor to place orders for equipment or materials a sufficient time in advance to ensure delivery when needed. Any extension of time granted by the Authority shall not release the Contractor and Surety herein from the payment of liquidated damages as provided in the General Conditions of this Contract, for a period of time not included in the original Contract or the time extension, as herein provided.

In no event shall the Authority be liable or responsible to the Contractor, Surety, or any person for or on account of any stoppage or delay of Work herein provided for by injunction or any other kind of legal, equitable proceedings, or from or by or on account of any delay from any other cause whatsoever.

**GC-15. ENGINEER'S POWERS AND DUTIES:**

The Engineer will provide general administration of the Contract, including performance of the functions hereinafter described.

The Engineer will be the Authority's representative during construction and until final payment. The Engineer will have authority to act on behalf of the Authority to the extent provided herein unless otherwise modified by written instrument, which will be shown to the Contractor. The Engineer will advise and consult with the Authority, and all of the Authority's instructions to the Contractor shall be issued through the Engineer. Nothing contained in the Contract documents shall create any contractual relationship between the Engineer and the Contractor.

The Engineer shall at all times have access to the Work as provided elsewhere herein. The Engineer will make periodic visits to the Work site to familiarize himself generally with the progress and quality of the Work and to determine in general whether the Work is proceeding in accordance with the Contract. On the basis of his on-site observations as Engineer, he will keep the Authority informed of the progress of the Work and will endeavor to guard the Authority against defects and deficiencies in the Work caused by the Contractor. The Engineer will not be responsible for construction means, methods, techniques, sequences, or procedures, or for safety precautions and programs in connection with the Work, and will not be responsible for the Contractor's failure to carry out the Work in accordance with the Contract. Based on such observations and the Contractor's applications for payment, the Engineer will determine the amounts owing to the Contractor and will issue certificates for payment in amounts as provided elsewhere herein.

The Engineer may provide one or more full-time project representatives to assist the Engineer in carrying out his responsibilities at the Work site. The duties, responsibilities and limitations of authority of the Engineer as the Authority's representative during construction as set forth herein will not be modified or extended without written consent

of the Authority, the Contractor and the Engineer.

The Engineer will not be responsible for the acts or omissions of the Contractor, any Subcontractors, or any of their agents or employees, or any other persons performing any of the Work.

The Engineer shall decide the meaning and intent of any portion of the specifications, and of any plans or Drawings, where the same are found to be obscure or be in dispute; he shall have the right to correct any errors or omissions therein when such corrections are necessary to further the intent of said specifications, plans or Drawings; the action of such correction shall be effective from the date that the Engineer gives due notice thereof.

Any differences or conflicts which may arise between the Contractor and other contractors with the Authority in regard to their work shall be adjusted as determined by the Engineer.

Neither the Engineer's authority to act under this article or elsewhere in the Contract nor any decision made by the Engineer in good faith either to exercise or not to exercise such authority shall give rise to any duty or responsibility of the Engineer to the Contractor, any Subcontractor, any manufacturer, fabricator, supplier or distributor, or any of their agents or employees or any other person performing any of the Work.

Whenever in the Contract the terms "as ordered", "as directed", "as required", "as allowed", or terms of like effect or import are used, or the adjectives "reasonable", "suitable", "acceptable", "proper", or "satisfactory" or adjectives of like effect or import are used, to describe requirements, direction, review or judgement of the Engineer as to the Work, it is intended that such requirement, direction, review, or judgement will be solely to evaluate the Work for compliance with the Contract (unless there is a specific statement indicating otherwise). The use of any such term or adjective never indicates that the Engineer shall have authority to supervise or direct performance of the Work or authority to undertake responsibility contrary to the provisions of this General Condition.

**GC-16. AUTHORITY'S RIGHT OF INSPECTION:**

The Authority shall appoint or employ such engineers or inspectors as the Authority may deem proper to inspect the materials furnished and the work performed, and to determine whether said materials are furnished and work is performed in accordance with the Drawings and specifications therefor. The Contractor shall furnish all reasonable aid and assistance required by the Engineer, or by the Inspectors, for the proper inspection and examination of the Work and all parts thereof, even to the extent of uncovering or taking out portions of finished Work. Should the Work thus exposed or examined prove satisfactory, the uncovering or removing and the replacing of the covering or the making good of the parts removed shall be paid for by the Authority; however, should the Work exposed or examined prove unsatisfactory, the uncovering, taking out, replacing, and making good shall be at the expense of the Contractor.

Such inspection shall not relieve the Contractor of any obligation to perform said Work

strictly in accordance with the Drawings and specifications or any modifications thereto as herein provided, and the Work not so constructed shall be removed and made good by the Contractor at his own expense, and free of all expense to the Authority, whenever so ordered by the Engineer, without reference to any previous oversight or error in inspection.

**GC-17. SUSPENSION OF WORK ON NOTICE:**

The Contractor shall delay or suspend the progress of the Work or any part thereof whenever he shall be so required by written order of the Authority or Engineer, and for such period of time as it or he shall require. Any such order of the Authority or Engineer shall not modify or invalidate in any way the provisions of this Contract.

**GC-18. QUALITY OF WORKMANSHIP:**

All workmanship shall be the best possible, both as to material and labor, that could be demanded by these Contract Documents, or if no specific description is given, it is understood that the best quality is required.

**GC-19. SATURDAY, SUNDAY, HOLIDAY, AND NIGHT WORK:**

No work shall be done between the hours of 7:00 p.m. and 7:00 a.m., nor on Saturday, Sunday, or legal holidays without the written approval or permission of the Engineer in each case, except such work as may be necessary for the proper care, maintenance, and protection of work already done, or of equipment, or in the case of an emergency. Allowable working times within secured facilities may be adjusted by Engineer as necessary to facilitate established operational shift schedules.

**GC-20. LAWS AND ORDINANCES:**

The Contractor shall keep himself fully informed of all existing and current regulations of the City, county, state and national laws which in any way limit or control the actions or operations of those engaged upon the Work, or affecting the materials supplied to or by them. The Contractor shall at all times observe and comply with all applicable ordinances, laws, and regulations, and shall protect and indemnify the Authority and the Authority's employee's officers and agents against any claims or liability arising from or based on any violations of the same.

The contractor certifies that it and all of its Subcontractors to be used in the performance of the Contract are in compliance with 25 O.S. Sec. 1313 and participate in the Status Verification System. The Status Verification System is defined in 25 O. S. Sec. 1312 and includes but is not limited to the free Employee Verification Program (E-Verify) available at [www.dhs.gov/E-Verify](http://www.dhs.gov/E-Verify).

The Contractor shall take the necessary actions to ensure its facilities are in compliance with the requirements of the Americans with Disabilities Act (ADA). It is understood that the program of the Contractor is not a program or activity of the City of Tulsa. The Contractor agrees that its program or activity will comply with the requirements of the ADA. Any costs of such compliance will be the responsibility of the Contractor. Under no circumstances will Contractor conduct any activity, which it deems to not be in compliance with the ADA.

**GC-21. TAXES AND PERMITS:**

Unless otherwise specified in these Contract Documents, the Contractor shall pay all sales, use, and other taxes that are lawfully assessed against the Authority or Contractor in connection with the Work included in this Contract and shall obtain all licenses, permits, and inspections required for the Work. Contractor shall comply with all zoning ordinances of the City, as provided in the Tulsa Zoning Code, Title 42 Tulsa Revised Ordinances and conform with all zoning requirements established by the Tulsa Metropolitan Area Planning Commission and the Board of Adjustment. Contractor can call the Indian Nations Council of Governments (INCOG) at (918) 584-7526, to determine if any zoning requirements must be met.

**GC-22. PROTECTION OF PROPERTY:**

The protection of City, state, and government monuments, street signs, and other City property is of prime importance, and if the same be damaged, destroyed, or removed, they shall be repaired, replaced, or paid for by the Contractor.

Work occurring within secured facilities will require the Contractor to obtain City of Tulsa issued ID badges for all employees and subcontractors requiring facility gate access. The Contractor will be responsible for all coordination with City Security as necessary to process background checks and issue badges. The City of Tulsa has the right to deny access to any individual based on evaluation of background check.

**GC-23. PATENT RIGHTS:**

All fees for any patented invention, article, or arrangement that is based upon, or in any manner connected with the construction, erection, or maintenance of the Work or any part thereof embraced in the Contract and these specifications, shall be included in the price stipulated in the Contract for said Work. The Contractor shall protect and hold harmless the Tulsa Metropolitan Utility Authority, against any and all demands of such fees or claims.

**GC-24. DEFENSE OF SUITS:**

In case any action at law or suit in equity is brought against the Authority or any employee, officer or agent thereof, for or on account of the failure, omission or neglect of the Contractor to do and perform any of the covenants, acts, matters, or things required by this Contract to be done or performed, or for injury or damage caused by negligence or willful act of the Contractor or his Subcontractors or his or their agents, or in connection with any claim or claims based on the lawful demands of Subcontractors, workmen, materialmen, or suppliers of machinery and parts thereof, equipment, power tools, and supplies incurred in the fulfillment of this Contract, the Contractor shall indemnify and save harmless the Authority and its employees, officers and agents, and the Engineer and any employees, officers and agents thereof, of and from all losses, damages, costs, expenses, judgements, or decrees whatsoever arising out of such action or suit that may be brought, without requiring said parties to give any notice thereof.

The Authority may suspend payments of any sum due or to become due for work done

on this Contract until such claims, suits, actions, or proceedings are final and liability has been determined. The amount of such damages or liability shall be deducted from sums due or to become due on this Contract. The sums mentioned above will be retained by the Authority until the Contractor furnishes evidence that satisfactory settlement has been made. Any action taken by the Authority shall not excuse the Contractor for failure to perform this Contract or bar the Authority from legal action to recover from the Contractor the amount of damages or liability suffered in excess of the amount retained.

The Contractor shall furnish the Authority with satisfactory evidence, upon demand, that all persons who have done work on the Contract or furnished materials for the Contract have been paid in full. If such evidence is not furnished, the amount necessary to pay the lawful claims may be retained until such evidence is furnished, or if such evidence is not furnished, the Authority may apply any sums retained to valid claims and charge the amounts disbursed, including the costs of any action that may be necessary to prove or disprove the claims against the Contractor.

**GC-25. REMOVAL OF CONDEMNED MATERIALS AND STRUCTURES:**

The Contractor shall remove from the site of the Work, without delay, all rejected and condemned materials or structures of any kind brought to or incorporated in the Work, and upon his failure to do so, or to make satisfactory progress in so doing, within forty-eight (48) hours after the service of a written notice from the Engineer ordering such removal, the condemned material or structures may be removed by the Authority and the cost of such removal be taken out of the money that may be due or may become due the Contractor by virtue of this Contract. No such rejected or condemned material shall again be offered for use by the Contractor under this or any other Contract under this project.

**GC-26. EXTRA WORK:**

If a modification increases the amount of the Work, and the added Work or any part thereof is of a type and character which can properly and fairly be classified under one or more Unit Price items of the Bid Form, then the added Work or part thereof shall be paid for according to the amount actually done and at the applicable Unit Price. Otherwise, such work shall be paid for as hereafter provided.

Claims for extra work will not be paid unless the Work covered by such claims was authorized in writing by the Authority. The Contractor shall not have the right to take action in court to recover for extra work unless the claim is based upon a written order from the Authority. Payments for extra Work will be based on agreed lump sums or on agreed Unit Prices whenever the Authority and the Contractor agree upon such prices before the extra Work is started.

For the purpose of determining whether proposed extra work will be authorized, or for determining the payment method for extra work, the Contractor shall submit to the Engineer, upon request, a detailed cost estimate for proposed extra work. The estimate shall show itemized quantities and charges for all elements of direct cost.

The cost shall include only those extra costs for labor and materials expended in direct performance of the extra work and may include:

- (a) **Labor.** For all labor and foremen in direct charge of the specific operations, the Contractor shall receive the rate of wage (or scale) agreed upon in writing before beginning work for each and every hour that said labor and foremen are actually engaged in such work. An amount equal to fifteen (15) percent of the sum of the above items will also be paid the Contractor.
- (b) **Bond, Insurance, and Tax.** For property damage, liability, and workmen's compensation insurance premiums, unemployment insurance contributions and social security taxes on the force account work, the Contractor shall receive the actual cost, to which cost no percentage will be added. The Contractor shall furnish satisfactory evidence of the rate or rates paid for such bond, insurance, and tax.
- (c) **Materials.** For materials accepted by the Engineer and used, the Contractor shall receive the actual cost of such materials delivered on the Work site, including transportation charges paid by him (exclusive of machinery rentals as hereinafter set forth), to which cost ten (10) percent will be added.
- (d) **Equipment.** For any machinery or special equipment (other than small tools) including fuel, lubricants and transportation costs, the use of which has been authorized by the Engineer, the Contractor shall receive the rental rates agreed upon in writing before such work is begun for the actual time that such equipment is in operations on the Work, as provided in Subsection 109.04(b3), to which rental sum no percentage will be added.
- (e) **Miscellaneous.** No additional allowance will be made for general superintendence, the use of small tools, or other costs for which no specific allowance is herein provided.

The form on which field cost records are kept, the construction methods and the type and quantity of equipment used shall be submitted to the Engineer for approval.

Construction equipment which the Contractor has on the Work site and which is of a type and size suitable for use in performing the extra Work shall be used. The hourly rental charges for equipment, including all insurance, taxes, fuel, and operating costs, shall not exceed twelve (12) percent of the latest applicable Associated Equipment Distributors published monthly rental rates and shall apply to only the actual time the equipment is used in performing the extra Work.

When extra Work requires the use of equipment, which the Contractor does not have on the work site, the Contractor shall obtain the approval of the Engineer before renting or otherwise acquiring additional equipment. The rental charges for the additional equipment shall not exceed the latest applicable Associated Equipment Distributors published rental rates.

The Contractor shall file with the Engineer, certified lists in duplicate, of any equipment and the schedule of pay rates for common and semi-skilled labor and operators of various classes which are intended to be used in performing the Work covered by this Contract. These rates shall be subject to the review of the Engineer. This information will be used by the Engineer for computation of extra work as mentioned above, however, if the Contractor fails to file these lists with the Engineer prior to starting any Work covered by this Contract, then the Engineer's computation shall be based on average wages and rates paid on Authority work.

GC-27. PAYMENT FOR CONTRACTOR'S PLANT AND MISCELLANEOUS TEMPORARY WORK:

For providing plant, tools, and equipment, and for furnishing, erecting, maintaining, and removing scaffolding and construction plant, construction roads, camps, sanitary conveniences, temporary water supply, trestles, dewatering and other temporary works, the Contractor shall receive no direct payment, but compensation for them shall be considered as having been included in the prices stipulated for the appropriate items.

GC-28. BASIS OF PAYMENT FOR ITEMS OF WORK:

The Contractor shall be paid for all Work performed under the Contract based on the Engineer's computations of as-built quantities and the Contractor's Unit Price or Lump Sum bid per item. This payment shall be full compensation for furnishing all supplies, materials, tools, equipment, transportation, and labor required to do the Work; for all loss or damage, because of the nature of the work, the action of the elements or any unforeseen obstruction or difficulty which may be encountered in the performance of the Work, and for which payment is not specifically provided; for all expense incurred by or because of any suspension or discontinuance of all or any part of the Work; and for faithfully completing the Contract according to the Drawings and specifications and requirements of the Engineer.

GC-29. PAYMENTS:

(1) Partial: If the work is progressing in good and workmanlike manner and if the Contractor is faithfully carrying out the terms of this Contract, approximate estimates of the work done shall be made by the Engineers between the first and fifteenth of each calendar month, including labor actually performed and supplies or materials actually used or incorporated in the Work, and an allowance will be made for acceptable materials satisfactorily delivered, stored and secured on the site of the Work in such amount as can be incorporated in the Work within a reasonable time. The Authority shall have a lien as owner on any materials stored on the site of the Work.

Each partial estimate for payment shall contain or have attached an affidavit in the form found in this book of specifications, as required by law.

The Contractor shall submit with each partial pay estimate a complete list of vendors and suppliers with itemized purchases and invoices from each vendor. Each list shall contain the name of the Contractor or Subcontractor ordering the materials or supplies, and the specific use or placement of each of the materials purchased by the Tulsa

Metropolitan Utility Authority for this project in accordance with Article IIB of the Contract. At the direction of the Contractor, the Tulsa Metropolitan Utility Authority will withhold retainage in the amount of 5% on materials and supplies to be purchased under the terms of this Contract. If fuels are purchased, they shall be limited to dyed diesel fuel and/or kerosene for non-highway use. No unleaded gasoline will be permitted.

Each month that work is performed for which payment is due, the Contractor shall submit to the Engineer an application for such payment, provided said payment is not less than \$1,000.00, and, if required, receipts or other vouchers from Subcontractors showing his payments to them shall be submitted.

Each estimate shall be of the approximate value of all work performed and materials in place or delivered to the Work site, determined as aforesaid from the beginning of this contract to the date fixed for the current estimate, from which shall be deducted five percent (5%), or a lesser amount approved by the Authority, and, in addition thereto, all previous payments and all other sums withheld under the foregoing provisions of this Contract, the remainder to become due and payable; after the estimate has been reviewed and signed by the Engineer and the Authority, shall pay the estimate in the regular manner in the amount determined as due unless it shall be known by the Authority that there is good reason under the terms of this Contract for withholding same.

When the Contractor has completed Work constituting more than fifty percent (50%) of the total Contract amount, the retainage will continue at two and one-half percent (2.5%) for the balance of the remaining work; provided, however, that the City or its duly authorized representative has determined that satisfactory progress is being made and upon approval by the Surety.

The Contractor may withdraw any part or the whole of the amount which has been retained from partial payment to the Contractor pursuant to the terms of Contract, upon depositing with or delivery to the City:

- (1) United States Treasury Bonds, United States Treasury Notes, United States Treasury bills, or
- (2) General Obligation Bonds of the State of Oklahoma, or
- (3) Certificates of Deposit from a state or national bank having its principal office in the State of Oklahoma.

No retained amount shall be withdrawn which would represent an amount in excess of the market value of the securities at the time of deposit or of the par value of such securities, whichever is lower.

All partial estimates are subject to correction in the final estimate.

(2) Final Payment:

When this contract, in the opinion of the Engineer, shall be completely performed on the part of the Contractor, the Engineer shall proceed with all reasonable diligence to measure up the Work and shall make out the final estimate for the same, and shall, except for cause herein specified, give to the Contractor, within thirty (30) days after receiving said certificate, an order on the Authority for the balance found to be due, excepting therefrom such sum or sums as may be lawfully retained under any of the provisions of the Contract; PROVIDED, that nothing herein contained shall be construed to affect the rights of the Authority hereby reserved to reject the whole or any portion of the aforesaid Work should the said estimate and certificate be found or known to be inconsistent with the terms of this Contract or otherwise improperly given; PROVIDED, that if after the work hereunder has been accepted and final payment made, it shall be discovered that any part of the Contract has not been fully performed or has been done in an improper or faulty manner, the Contractor shall immediately remedy such defect, or, in case of neglect to do so within a reasonable time after notice thereof, shall be liable for and shall pay to the Authority the cost of remedying such defect or a sum equal to the damages sustained thereby, as the Authority shall elect and the acceptance of and final payment for the Work shall be no bar to suit on any bond against any principal or principals, or Surety or Sureties, or both, given for the due performance of the Contract, or for the recovery of such cost or the equivalent of such damage.

The Authority will pay to the Contractor interest at the rate of three-fourths percent (3/4%) per month on the final payment due the Contractor. For lump sum contracts, the interest shall commence thirty (30) days after the Work under the Contract has been completed and accepted and all required material certifications and other documentation required by the Contract have been furnished the Authority by the Contractor, and shall run until the date when the final payment or estimate is tendered to the Contractor. For contracts bid by Unit Prices, the interest will commence sixty (60) days after the above conditions are satisfied. When contract quantities or the final payment amount is in dispute, the interest-bearing period will be suspended until the conclusion and settlement of the dispute.

**GC-30. CONTRACTOR REIMBURSEMENT FOR SURETY BOND:**

For contracts of \$1,000,000.00 or more, the Contractor may receive reimbursement for the cost of the surety bonds after issuance of a work order. To receive reimbursement, the Contractor shall submit a standard partial payment form and affidavit, and a copy of the surety bond invoice. The final partial pay estimate will be reduced by the amount paid for surety bond reimbursement.

**GC-31. RELEASE OF LIABILITY AND ACCEPTANCE:**

The acceptance by the Contractor of the final payment shall operate as, and shall be a release to the Authority and every employee, officers and agents thereof, from all claims and liability to the Contractor for anything done or furnished for or relating to the Work, or for any act or neglect of the Authority or of any person relating to or affecting the Work, and, following such acceptance, no person, firm, or corporation other than the signer of this Contract as Contractor, will have any interest hereunder, and no claim shall be made or be valid, and neither the Authority nor any employees or agent thereof

shall be liable or be held to pay any money, except as herein provided.

It shall be the duty of the Engineer to determine when the Work is completed and the Contract fulfilled, and to recommend its acceptance by the Authority. The Work herein specified to be performed shall not be considered finally accepted until all the Work has been accepted by the Authority.

**GC-32. RIGHT OF AUTHORITY TO TERMINATE CONTRACT:**

If the Work to be done under this Contract shall be abandoned by the Contractor, or if this Contract shall be assigned by him otherwise than as herein provided, or if the Contractor should be adjudged bankrupt, or if a general assignment of his assets be made for the benefit of his creditors, or if a receiver should be appointed for the Contractor or any of his property; or if at any time the Engineer shall certify in writing to the Authority that the performance of the Work under this Contract is being unnecessarily delayed, or that the Contractor is executing the same in bad faith or otherwise not in accordance with the terms of the Contract; or if the work be not substantially completed within the time named for its completion, or within the time to which such completion date may be extended; then the Authority may serve written notice upon the Contractor and his Surety of Authority's intention to terminate this Contract, and unless, within five (5) days after service of such notice upon the Contractor, a satisfactory arrangement is made for the continuance of the Contract, this Contract shall cease and terminate. In the event of such termination, the Authority shall immediately serve notice upon the Surety and Contractor, and the Surety shall have the right to take over and complete the Work, provided, however, that if the Surety does not commence performance thereof within fifteen (15) days from the date of said notice of termination, the Authority may take over the Work and perform same to completion, by Contract or otherwise, for the account and at the expense of the Contractor, and the Contractor, and his Surety, shall be liable to the Authority for any and all excess cost sustained by the Authority by reason of such performance and completion. In such event the Authority may take possession of and utilize in completing the Work, all such materials, equipment, tools, and plant as may be on the site of the Work and necessary therefor. The Contractor shall not receive any other payment under the Contract until said Work is wholly finished, at which time, if the unpaid balance of the amount to be paid under the Contract shall exceed the expense incurred by the Authority in finishing the Work as aforesaid, the amount of the excess shall be paid to the Contractor, but if such expense shall exceed the unpaid balance, the Contractor shall pay the difference to the Authority.

**GC-33. ADMINISTRATIVE COSTS AND FEES:**

Cash Improvements - In the event the improvements are to be paid for in cash: the costs and fees for publication, engineering, filing, recording, abstracting, acquisition of easements, flushings, and pipe testing, shall be paid by the Authority unless otherwise provided for in these Contract Documents.

Assessment Improvements: In the event the improvements are to be paid for by the issuance of special assessment bonds, the costs and fees for publication, engineering, filing, recording, abstracting, acquisition of easements, flushing, pipe testing, and other

authorized costs shall be added to the contract price and paid for in the same manner as the other Work included in this Contract. The Contractor shall pay the Authority the amount of said charges before the execution and delivery of the special assessment bonds or other payments. If the Contractor fails, neglects, or refuses to pay said charges within thirty (30) days after the bonds are ready for delivery, he shall pay the Authority interest at the rate of seven percent (7%) per annum and shall be liable for same in a civil suit. The Contractor shall pay the pipe testing fees directly to the testing laboratory.

**GC-34. PAYMENT OR ACCEPTANCE NOT A WAIVER BY AUTHORITY:**

Neither acceptance by the Authority or the Engineer or any employee of either nor any order by Authority for the payment of money, or the payment thereof, nor any taking of possession by Authority, nor the granting of any extension of time, shall operate as a waiver of any rights or powers of the Authority hereunder, and in the event that after the Work hereunder has been accepted and final payment made, it should be discovered that any part of this Contract has not been fully performed, or has been done in a faulty or improper manner, the Contractor shall immediately remedy such defect, or in the event of neglect to do so within a reasonable time after notice thereof, shall be liable for and shall pay to Authority the cost of remedying such defect, or a sum equal to the damage caused thereby, as Authority may elect. The acceptance of the Work or final payment therefor shall be no bar to suit against the Contractor or Surety, or both.

**GC-35. CONTRACTOR'S OBLIGATION AFTER ACCEPTANCE:**

Contractor further agrees, without cost other than is specially provided for in this Contract, at any and all times during one (1) year next following the completion and final acceptance of the Work embraced in this Contract, without notice from Authority, to refill all trenches or ditches that may sink or settle; and to repair all breaks and failures that may occur in the construction work due to defective material or workmanship; and to indemnify, save harmless and defend the Authority from any and all suits and actions of every description brought against Authority for, or on account of injuries or damages alleged to have been received or sustained by any party or parties by reasons of, or arising out of the failure of Contractor to refill all trenches and ditches and to repair all breaks or failures of said construction work, which said injuries or damages are alleged to have been received or incurred within one (1) year from the final acceptance of the Work hereunder, and to pay any and all judgements that might be rendered against Authority in any suits and actions, together with such expenses or attorney's fees expended or incurred by Authority in the defense thereof, and Contractor hereby expressly waives any notice that might by law be required to be given to them by Authority of any defect, break, settling, or failure or of any other condition that might be the cause of injury or damage to any person on account of which a claim or suit might be made or filed against Authority, or a judgement taken for damages against Authority. It is expressly agreed that the acceptance of the Work by Authority shall constitute no bar against any person injured or damaged by the failure of the Contractor to perform all of his covenants and agreements hereunder from maintaining an action against the Contractor, or against Authority from enforcing its rights against the Contractor hereunder.

**GC-36. NOTICES:**

Any notices or other communications hereunder may be given to Contractor at the address listed in the Proposal, to the Surety at the office of the Attorney-in-Fact signing the bond or at Surety's home office address on file with the Insurance Commissioner of the State of Oklahoma, and to Authority in care of the City of Tulsa's Director of Public Works, or at such other place as may be designated in writing. The delivery at such address, or depositing in any mailbox regularly maintained by the Post Office, of any notice, letter, or other communication to the Contractor, shall be deemed sufficient service thereof, and the date of said service shall be the date of such delivery or mailing.

**GC-37. RELATION TO OTHER CONTRACTORS:**

Nothing herein contained and nothing marked upon the Drawings shall be interpreted as giving the Contractor exclusive occupancy of the territory or right-of-way provided. The Authority and its employees, officers, and agents for any just purpose, and other contractors of the Authority for any purpose required by their respective contracts, may enter upon or cross this territory or occupy portions of it or take materials therefrom as directed or permitted. When two or more contracts are being executed at one time on the same or adjacent land in such manner that the work on one contract may interfere with the work on another, the Engineers shall decide which contractor shall cease work and which shall continue, or whether the work on both contracts shall progress at the same time and in what manner. When the territory of one contract is the necessary or convenient means of access for the transportation or movement of men, machines, or appliances for the execution of another contract, such privilege of access or any other reasonable privilege may be granted by the Engineers to the contractor desiring it, to the extent, amount, in the manner and at the time permitted. Any decision regarding the method or time of conducting the work or the use of the territory shall not be made the basis of claims for delay or damage except as otherwise stipulated. The Contractor shall not cause any unnecessary hindrance or delay to any other contractors on the premises and shall bear all damages done to the work of such other contractors by him or by his employees.

**GC-38. PARTIAL OCCUPANCY AND USE:**

The Authority, upon advance written notification to the Contractor, shall have the right to occupy and use any completed or partially completed portions of the Work site when such occupancy and use are in the Authority's best interest, notwithstanding completion of the entire project.

Such partial occupancy and use shall be upon the following terms:

- a. The Engineer shall make an inspection of the portion or portions of the Work concerned, and report to the Authority his findings as to the acceptability and completeness of the Work. The Engineer's report shall include a list of items to be completed or corrected before final payment.
- b. The Authority, upon acceptance of the Engineer's report, shall give

written notice to the Contractor of the Authority's intention to occupy and use said portions of the Work site. The Authority's notice shall include a copy of the Engineer's report, shall clearly identify the portions of the Work site to be occupied and used, and shall establish the date of said occupancy and use.

- c. From the date thus established, the Authority shall assume all responsibilities for operation, maintenance, and the furnishing of water, gas, and electrical power for the portions of the Work site thus occupied and used. The Authority shall have the right to exclude the Contractor from those portions of the Work site but shall provide the Contractor reasonable access to complete or correct necessary items of Work.
- d. The one-year guarantee required by the General Conditions shall not begin until completion and final acceptance of the entire project. If, before final acceptance, the Contractor completes any mechanical or electrical equipment such as pumps, blowers, process equipment, instrumentation, controls, metering equipment, heating, and ventilation equipment and similar items having movable or operable components, the Contractor may then request partial acceptance of each completed equipment system. In response, the Engineer will perform a final inspection of each system and determine if all specifications are satisfied, including but not limited to start-up conditions, performance criteria, control systems, training, and final operation manuals (O & M's). Once found to be complete, ready for operation, and isolated from all remaining work, the Engineer will provide Contractor with written notice of partial acceptance and the start date for the one-year guarantee required by the General Conditions.
- e. Occupancy or use of any space in the Work site shall not constitute acceptance of Work not performed in accordance with the Contract, nor relieve the Contractor of liability to perform any Work required by the Contract but not completed at the time of said occupancy and use.
- f. The Contractor shall not be held responsible for normal wear and tear or damage resulting from said occupancy, except to the extent that such damage is covered by the one-year guarantee.
- g. The partial occupancy and use of any portions of the Work site by the Authority shall not constitute grounds for claims by the Contractor for release of any amounts retained from payments under the provisions of the Contract. The retained amounts will not be due until completion of the entire project for final acceptance and final payment, as set forth in the General Conditions.

SPECIAL  
PROVISIONS

SPECIAL PROVISION  
SUPPLEMENTAL CONTRACT REQUIREMENTS  
PROJECT NO. ES 2022-09 SPUNKY CREEK INTERCEPTOR MAIN STEM  
SOUTH PHASE 3

1. Apparent lowest, responsible bidder shall return their signed contract documents (including bonds and insurance) to the City of Tulsa, Contract Administration Section 175 E. 2<sup>nd</sup> Street, 13<sup>th</sup> Floor, OK 74103 within fifteen (15) days after notification by the City.
2. If the apparent lowest, responsible bidder provides their signed contract documents (including bonds and insurance) and the contract is executed by the City, the Pre-Construction Conference for this project will be held within sixty (60) days after bid opening.
3. The Notice to Proceed or written work order (NTP) will be issued in the normal time period (approximately within ten (10) days of the Pre-Construction Conference).

The City will grant up to **ninety (90) days** for a delayed (flexed) NTP after the Pre-Construction Conference. No delayed (flexed) NTP above this amount will be granted unless approved by the City Engineer or designee.

4. There will be no additional compensation due to the use of a delayed (flexed) NTP.
5. This Special Provision does not alter the Public Meeting requirements (and public notice) defined in the General Conditions.

SPECIAL PROVISIONS  
INSURANCE REQUIREMENTS

In reference to Ordinance No. 24616 Adoption of State Specification for Highway Construction, Section 107.12 shall be modified as follows:

The CONTRACTOR (and any subcontractors) shall carry and keep in force during this Contract, policies of insurance issued by an insurer authorized to transact business in Oklahoma in minimum amounts as set forth below or as required by the laws of the State of Oklahoma. The CONTRACTOR shall also furnish an Owner's Protective Policy in the same amounts naming the Tulsa Metropolitan Utility Authority as the assured, issued by the same insurance company as the CONTRACTOR'S liability coverage and indemnifying the Tulsa Metropolitan Utility Authority against any and all actions, claims, judgments or demands arising from injuries of any kind and character sustained by any person or persons because of work performed by the CONTRACTOR.

General Liability Insurance with a bodily injury and property damage combined single limit of not less than \$1,000,000.00 for each occurrence.

Employer's Liability and Workmen's Compensation in the amounts as required by law.

The CONTRACTOR shall provide proof of such coverage:

- (a) By providing Certificate(s) of Insurance prior to the execution of this contract; and
- (b) By submitting updated Certificate(s) of Insurance with each and every subsequent request for payment. The Certificate(s) should show that the policies are current and should be dated within 30 days of payment request.

The CONTRACTOR shall not cause any required insurance policy to be cancelled or permit it to lapse. If the CONTRACTOR cancels, allows to lapse, fails to renew or in any way fails to keep any required insurance policy in effect, the City will suspend all progress and/or final payments for the project until the required insurance is obtained. Further, a CONTRACTOR who fails to keep required insurance policies in effect may be deemed by the City to be in breach of contract, ineligible to bid on future projects, and/or ineligible to engage in any new contracts.

The Contractor shall execute and furnish a Statutory Bond for the protection of laborers, mechanics, and material men in a sum equal to one hundred percent (100%) of the contract price.

The Contractor shall execute and furnish a Performance Bond in a sum equal to one hundred percent (100%) of the contract price.

The Contractor shall execute and furnish a Maintenance Bond in a sum equal to one hundred percent (100%) of the contract price.

Prior to doing blasting, the Contractor shall furnish a Certificate of Insurance, which shall certify that any damage caused by blasting is within the coverage of the Contractor's liability insurance to the full limits thereof.

All bonds and insurance must be executed by a company licensed to do business in the State of Oklahoma and must be acceptable to the City.

**SPECIAL PROVISIONS**  
**OWNER ALLOWANCE**

The "Owner Allowance" may be used for various work and miscellaneous items not specifically identified in the Contract Documents with the following provisions:

- A. The allowance shall be used for cost of design and construction, including all materials, labor, equipment, profit and overhead, of work items not specifically identified in the Construction Documents, or included in original pay items bid for the contract.
- B. The allowance shall be utilized only at the discretion of the City of Tulsa. Any balance remaining at the completion of the Project will be retained by the City of Tulsa.
- C. The Contractor shall provide, to the City of Tulsa, a written request for the use of any allowance, including a schedule of values and associated backup information, including validity of need, materials, labor, equipment, and time required to perform the associated work.

Contractor shall proceed with the allowance work only after receiving written permission from the City of Tulsa. Proceeding with associated allowance work without written permission from the City of Tulsa will be at the Contractor's sole expense.

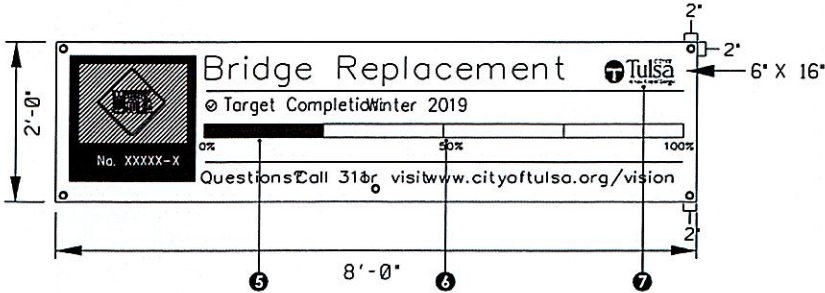
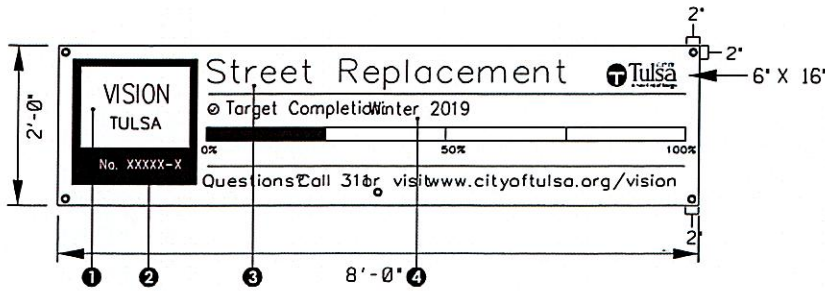

**NOTE:**

1. CAPITAL PROGRAM LOGO
  - VISION TULSA
  - IMPROVE OUT TULSA
2. PROJECT NUMBER
  - FONT: HELVETICA BOLD
  - SIZE: 2.5 INCHES
  - ALIGNMENT: CENTER
  - COLOR: WHITE
3. GENERAL PROJECT TITLE
  - FONT: HELVETICA BOLD
  - SIZE: 4.72 INCHES
  - ALIGNMENT: LEFT
  - COLOR: CITY BLUE
  - GENERALIZED
    - STREET REPLACEMENT
    - STREET REHABILITATION
    - STREET WIDENING
    - STREET RESURFACING
    - BRIDGE REPLACEMENT
    - BRIDGE REHABILITATION
4. TARGET COMPLETION
  - FONT: HELVETICA REGULAR AND BOLD
  - SIZE: 2.5 INCHES
  - ALIGNMENT: LEFT
  - COLOR: CITY BLUE AND BLACK
5. PROJECT PROGRESS BAR
  - SIZE: 2" TALL X 66" WIDE
  - COLOR: GREEN
  - MATERIAL: 2" GREEN, INDUSTRIAL DUCT TAPE CUT AT 1/4 SEGMENTS SHOULD BE USED TO INDICATE PROJECT PROGRESS/ADVANCEMENTS IN THE PROGRESS BAR. PAINT SHOULD ONLY BE USED IN THE EVENT THAT TAPE IS NOT AVAILABLE OR UNABLE TO REMAIN AFFIXED OVER A LONGER CONSTRUCTION PERIOD.
6. CONTACT INFORMATION
  - OPTIONS: 311 AND CORRESPONDING URL
  - FONT: HELVETICA REGULAR AND BOLD
  - SIZE: 2.5 INCHES
  - ALIGNMENT: LEFT
  - COLOR: CITY BLUE AND BLACK
7. CITY OF TULSA LOGO
  - SIZE: 10" WIDE
  - ALIGNMENT: OUTER RIGHT MARGIN EDGE AND TO THE BASELINE OF THE GENERAL PROJECT TITLE.

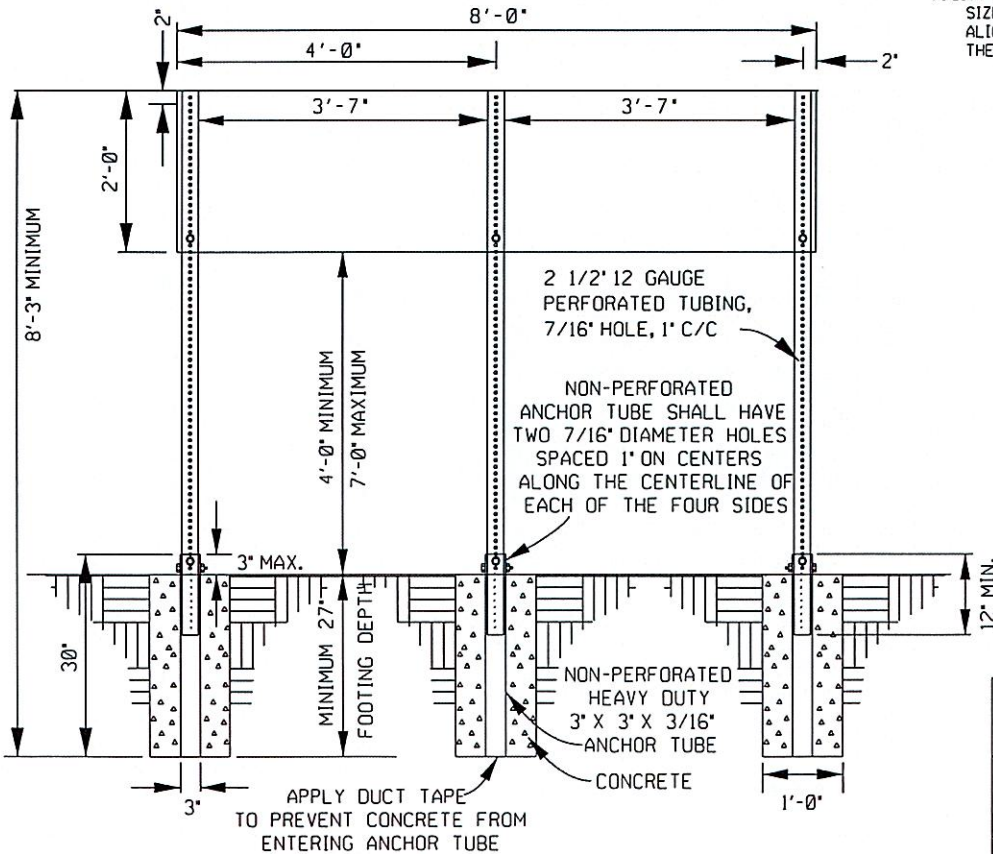

ASSEMBLY OF PLYWOOD SIGN

PROJECT SIGN	
CITY OF TULSA, OKLAHOMA ENGINEERING SERVICES DEPARTMENT	
DRAWN BY:	APPROVED
CHECKED BY: <i>HAS</i>	<i>[Signature]</i>
DATE: MARCH 2022	
NOT TO SCALE	STANDARD NO. 102

**SPECIAL PROVISION**  
**FOR UTILITY RELOCATIONS**  
**AND DESIGN ISSUES**

It is the intent of this specification to provide no more than seventy-five **(75)** calendar days due to delays caused by required utility relocations and required design clarifications. Should the Contractor be delayed in the final completion of work by any utility relocation or design issue, additional days as determined by the Engineer shall be granted by the City. However, the Contractor shall give the Engineer notice in writing of the cause of the delay in each case on the Extension of Time Request Form enclosed in these documents, and agrees that any claim shall be fully compensated for by the provisions of this specification to complete performance of the work. An adjustment will not be made to the contract time bid for incentive purposes.

Any time granted for utility relocations or design issues up to **(75)** calendar days will be in addition to the number of days shown in the proposal for computation of disincentive and liquidated damages.

# SPECIFICATIONS

## **SPECIFICATIONS**

- A. Oklahoma Department of Transportation Standard Specifications for Highway Construction, 2019 Edition as modified by Ordinance 24616, shall be used on this project including Section 100-General Provisions.
  
- B. City of Tulsa, Public Work, Engineering Division, Construction Specifications – March 2022 are incorporated herein as if fully set forth and are on file, including all revisions posted on internet prior to bid opening, with the Public Works Department, Engineering Division, 175 E. 2<sup>nd</sup> Street, Tulsa, Oklahoma or access on the internet at:  
<https://www.cityoftulsa.org/government/departments/public-works/engineering-services/specifications-checklists-and-details/>

TECHNICAL  
SPECIFICATIONS

**SPECIAL PROVISIONS FOR  
SPUNKY CREEK INTERCEPTOR MAIN  
STEM SOUTH, PHASE 3**

**TMUA PROJECT NO. ES 2022-09  
ENGINEERING SERVICES DEPARTMENT  
CITY OF TULSA, OKLAHOMA**

ENGINEER:  
**RJN GROUP, INC.**  
4500 S. Garnett Rd., Ste. 110  
Tulsa, OK 74146  
918.627.9737

## TECHNICAL REQUIREMENTS AND SPECIFICATIONS

### TABLE OF CONTENTS

#### **SPECIAL PROVISIONS**

SP-1 FRP Pipe for Direct Bury Installation – Gravity Service	3
SP-2 Pipe Transitions	6
SP-3 Fiberglass Reinforced Polyester Manholes Water Tight Type	7
SP-4 FRP Tee Base Manholes	11
SP-5 Composite Manhole Frame & Cover	15
SP-6 Manhole and Catch Basin Grade Adjusting Ring Specification	16
SP-7 Large Diameter Polyvinyl Chloride (PVC) Gravity Sewer Pipe Fittings	20
SP-8 Modification to City of Tulsa Standard Specification 301	
Right-of-Way Clearing and Restoring	23
SP-9 Removed from Special Provisions	24
SP-10 Sanitary Sewer Construction Form	25
SP-11 Sanitary Sewer Bypass Pumping Notification	26
SP-12 Pipe Culverts and Culvert End Treatments	28
SP-13 Steel Frame Gates	29
SP-14 Geotextile Reinforcement	30
SP-15 Stone Creek Farms Lift Station Abandonment	31
SP-16 Articulated Concrete Block Matting	33
SP-17 USACE Permitting	38

## **SP-1 TECHNICAL REQUIREMENTS AND SPECIFICATIONS**

### **FRP PIPE FOR DIRECT BURY INSTALLATION – GRAVITY SERVICE**

---

#### **PART 1 GENERAL**

- 1.1 Section Includes  
Centrifugally Cast Reinforce Fiberglass Mortar Pipe (CCFRPM) and filament wound glass-reinforced polymer (GRP) pipe.
- 1.2 References  
ASTM D3262 - Standard Specification for "Fiberglass" (Glass-Fiber-Reinforced Thermosetting-Resin) Sewer Pipe.  
ASTM D4161 - Standard Specification for "Fiberglass" (Glass-Fiber-Reinforced Thermosetting-Resin) Pipe Joints Using Flexible Elastomeric Seals.  
ASTM D2412 - Standard Test Method for Determination of External Loading Characteristics of Plastic Pipe by Parallel-Plate Loading.  
ASTM D3681 – Standard Test Method for Chemical Resistance of "Fiber glass" Pipe in a Deflected Condition.  
ASTM D638 – Test Method for Tensile Properties of Plastics.  
ASTM F1417 - Standard Practice for Installation Acceptance of Plastic Non-pressure Sewer Lines using Low-Pressure Air

#### **PART 2 PRODUCTS**

##### **2.1 MATERIALS**

- A. Resin Systems: The manufacturer shall use only polyester resin systems with a proven history of performance in this particular application. The historical data shall have been acquired from a composite material of similar construction and composition as the proposed product.
- B. Glass Reinforcements: The reinforcing glass fibers used to manufacture the components shall be of highest quality commercial grade E-glass filaments with binder and sizing compatible with impregnating resins.
- C. Silica Sand: Sand shall be minimum 98% silica with a maximum moisture content of 0.2%.
- D. Additives: Resin additives, such as curing agents, pigments, dyes, fillers, thixotropic agents, etc., when used, shall not detrimentally effect the performance of the product.
- E. Elastomeric Gaskets: Gaskets shall meet ASTM F477 and be supplied by qualified gasket manufacturers and be suitable for the service intended.

##### **2.2 MANUFACTURE AND CONSTRUCTION**

- A. Pipes: Manufacture pipe by the centrifugal casting or filament wound process to result in a dense, nonporous, corrosion-resistant, consistent composite structure. The interior surface of the pipes exposed to sewer flow shall be manufactured using a resin with a 50% elongation (minimum) when tested in accordance with D638. The interior surface shall provide crack resistance and abrasion resistance. The exterior surface of the pipes shall be comprised of a sand and resin layer which provides UV protection to the exterior.

- B. Joints: Unless otherwise specified, the pipe shall be field connected with fiberglass sleeve couplings that utilize elastomeric sealing gaskets as the sole means to maintain joint watertightness. The joints must meet the performance requirements of ASTM D4161. Joints at tie-ins, when needed, may utilize gasket-sealed closure couplings.
- C. Fittings: Flanges, elbows, reducers, tees, wyes, laterals and other fittings shall be capable of withstanding all operating conditions when installed. They may be contact molded or manufactured from mitered sections of pipe joined by glass-fiber-reinforced overlays. Properly protected standard ductile iron, fusion-bonded epoxy-coated steel and stainless steel fittings may also be used.
- D. Acceptable Manufacturer: Centrifugally Cast Reinforce Fiberglass Mortar Pipe (CCFRPM) as manufactured by Hobas Pipe USA, Inc. or a filament wound glass-reinforced polymer (GRP) pipe as manufactured by Hobas Pipe USA, Inc. and FLOWTITE™ as manufactured by Thompson Pipe Group, Inc. are approved for use on this project as a gravity sewer (per ASTM D3262). In all cases, stiffness class SN72 shall be used on this project for the installation of carrier sewer pipe.

### 2.3 DIMENSIONS

- A. Diameters: The actual outside diameter of standard pipe (nominal 18" to 60") shall be in accordance with ASTM D3262. For other diameters, OD's shall be per manufacturer's literature.
- B. Lengths: Pipe shall be supplied in nominal lengths of 20 to 40 feet. Actual laying length shall be nominal +1, -4 inches. At least 90% of the total footage of each size and class of pipe, excluding special order lengths, shall be furnished in nominal length sections.
- C. Wall Thickness: The minimum wall thickness shall be the stated design thickness.
- D. End Squareness: Pipe ends shall be square to the pipe axis with a maximum tolerance of 1/8".

### 2.4 TESTING

- A. Pipes: Pipes shall be manufactured and tested in accordance with ASTM D3262.
- B. Joints: Coupling joints shall meet the requirements of ASTM D4161.
- C. Stiffness: Minimum pipe stiffness when tested in accordance with ASTM D2412 shall normally be 72 psi.
- D. Strain Corrosion: The extrapolated 50-year strain corrosion value shall not be less than 0.9% as determined in accordance with ASTM D3681 and ASTM D3262.

### 2.5 CUSTOMER INSPECTION

- A. The Owner or other designated representative shall be entitled to inspect pipes or witness the pipe manufacturing.
- B. Manufacturer's Notification to Customer: Should the Owner request to see specific pipes during any phase of the manufacturing process, the manufacturer must provide the Owner with adequate advance notice of when and where the production of those pipes will take place.

### 2.6 PACKAGING, HANDLING, SHIPPING

- A. Packaging, handling, and shipping shall be done in accordance with the manufacturer's instructions.

PART 3 EXECUTION

3.1 INSTALLATION

A. Burial:

2.1 The bedding and burial of FRP pipe and fittings in non-paved areas outside of City right-of-way shall be in accordance with the Drawings.

2.2 The bedding and burial of FRP pipe and fittings and pavement restoration within City right-of-way, or under existing pavement, shall be in accordance with City of Tulsa Standard Detail No. 713.

B. Pipe Handling: Use textile slings, other suitable materials or a forklift. Use of chains or cables is not recommended.

Jointing:

Clean ends of pipe and coupling components.

Apply joint lubricant to pipe ends and elastomeric seals of coupling. Use only lubricants approved by the pipe manufacturer.

Use suitable equipment and end protection to push or pull the pipes together.

Do not exceed forces recommended by the manufacturer for coupling pipe.

Join pipes in straight alignment then deflect to required angle. Do not allow the deflection angle to exceed the deflection permitted by the manufacturer.

Bell holes shall be provided at each joint to permit proper joint assembly and alignment. After joint assembly, fill the bell holes with bedding material and compact as required.

When using movable trench supports, care should be exercised not to disturb the pipe location, jointing or its embedment.

Field Tests:

Low Pressure Air Test: After installation of the pipe, each reach shall be tested with the method as outlined in City of Tulsa Standard Specification Section 408.11. The low pressure air test shall be done in accordance with ASTM F1417. To pass the low pressure air test, the allowable limit is equal to or less than 10 gallons per inch of pipe diameter per mile per day at 2 feet of head as required by OAC 252:656-5-5(b).

Deflection: Perform deflection tests on all pipe after the final backfill has been in place at least 30 days. Maximum allowable long-term deflection shall not exceed 5% of the average initial diameter. Tests shall be performed using a rigid ball or mandrel with a diameter equal to 95% of the average inside diameter of the pipe taking into consideration manufacturing tolerances. Tests shall be performed without mechanical pulling devices. The deflection test shall be done in accordance with ASTM D3262.

CCTV Inspection: After installation of the pipe, Contractor shall contact Field Engineering staff to request scheduling for Sewer Operations & Maintenance to TV inspect the line as specified in City of Tulsa Standard Specifications.

All field tests shall be scheduled and coordinated with the Engineer.

END OF SECTION

## **SP-2 TECHNICAL REQUIREMENTS AND SPECIFICATIONS**

### **PIPE TRANSITIONS**

---

#### **PART 1 GENERAL**

- 1.1 Each reach of sewer shall be constructed using the same type of pipe between the structures at each end of the reach. Transitions between pipe types may only be made at the manholes.

**END OF SECTION**

## **SP-3 TECHNICAL REQUIREMENTS AND SPECIFICATIONS**

### **FIBERGLASS REINFORCED POLYESTER MANHOLES WATER TIGHT TYPE**

---

---

#### **PART 1 GENERAL**

- 1.1 Section Includes:
- A. Fiberglass Reinforced Polyester (FRP) Manholes.

#### **PART 2 PRODUCTS**

##### **2.1 MATERIALS**

- A. Fiberglass reinforced polyester manhole shall be manufactured from commercial grade polyester resin or other suitable polyester or vinyl ester resins with fiberglass reinforcements. Manhole shall be a one-piece unit manufactured to meet or exceed all specifications of A.S.T.M. D-3753 latest edition as manufactured by L.F. Manufacturing, Inc., Giddings, Texas, 1-800-237-5791, or an approved equal.
- B. Resin: The resins used shall be a commercial grade unsaturated polyester resin or other suitable polyester or vinyl ester resin.
- C. Reinforcing Materials: The reinforcing materials shall be commercial Grade "E" type glass in the form of continuous roving and chop roving, having a coupling agent that will provide a suitable bond between the glass reinforcement and the resin.
- D. Interior Surfacing Material: The inner surface exposed to the chemical environment shall be a resin-rich layer of 0.010 to 0.020 inch thick. The inner surface layer exposed to the corrosive environment shall be followed with a minimum of two (2) passes of chopped roving of minimum length 0.5 inch (13 mm) to maximum length of 2.0 inch (50.8 mm) and shall be applied uniformly to an equivalent weight of 3 oz/ft. Each pass of chopped roving shall be well rolled prior to the application of additional reinforcement. The combined thickness of the inner surface and interior layer shall not be less than 0.10 inch (2.5 mm).
- E. Wall Construction Procedure: After the inner layer has been applied the manhole wall shall be constructed with chop and continuous strand filament wound manufacturing process, which insures continuous reinforcement and uniform strength and composition. The cone section, if produced separately, shall be affixed to the barrel section at the factory with resin-glass reinforced joint resulting in a one-piece unit. Seams shall be fibreglassed on the inside and the outside using the same glass-resin jointing procedure. Field joints shall not be acceptable by anyone other than L.F. Manufacturing, Inc. Giddings, Texas or an approved equal.
- F. Exterior Surface: For a UV inhibitor the resin on the exterior surface of the manhole shall have gray pigment added to a minimum thickness of 0.125 inches.
- G. Stubouts and Connections: Upon request stubouts may be installed. Installation of CCFRPM, GRP, PVC, or other sewer pipe material must be performed by sanding, priming, and using resin fiber-reinforced hand lay-up. The resin and fiberglass shall be the same type and grade as used in the fabrication of the fiberglass manhole. Inserta-Tee fittings may be requested and installed per manufacturer's instructions. Kor-N-Seal boots

may be installed by the manhole manufacturer using fiberglass reinforced pipe stubouts for the Kor-N-Seal boot sealing surface.

- H. Manhole Bottom: Fiberglass manholes will be required to have resin fiber-reinforced bottom. Deeper manholes may require a minimum of two (2) fiberglass channel stiffening supports. All fiberglass manholes manufactured with a fiberglass bottom will have a minimum 3-inch wide anti-flotation ring. The manhole bottom shall be a minimum of ½ inch thick.
- I. Fiberglass enclosed invert and bench area: A fiberglass enclosed invert and bench area shall be installed in the manhole by the manufacturer. The invert will be formed using a non-corrosive material and completely enclosed in a minimum 1/4-inch layer of fiberglass chop.
- J. Height Adjustment: Fiberglass manholes must have the ability to be height adjustable with the use of a height adjustment ring. Height adjustment can be made as a field operation without the use of uncured resins or fiberglass lay-ups. Fiberglass manholes must maintain all load and soundness characteristics required by A.S.T.M. D-3753 after height adjustment has occurred.
- K. Fillers and Additives: Fillers, when used, shall be inert to the environment and manhole construction. Sand shall not be accepted as an approved filler. Additives, such as thixotropic agents, catalysts, promoters, etc., may be added as required by the specific manufacturing process to be used to meet the requirements of the A.S.T.M. D-3753 standard. The resulting reinforced-plastic material must meet the requirements of this specification.

## 2.2 MANUFACTURE AND CONSTRUCTION

- A. Manhole cylinders, manway reducers, and connectors shall be produced from fiberglass-reinforced polyester resin using a combination of chop and continuous filament wound process.
- B. Interior Access: All manholes shall be designed so that a ladder or step system can be supported by the installed manhole.
- C. Manway Reducer: Manway reducers will be concentric with respect to the larger portion of the manhole diameters through 60 inches. Larger manholes may have concentric or eccentric manway reducer openings.
- D. Cover and Ring Support: The manhole shall provide an area from which a grade ring or brick can be installed to accept a typical metal ring and cover and have the strength to support a traffic load without damage to the manhole.
- E. Exterior Surface: The exterior surface shall be relatively smooth with no sharp projections. Handwork finish is acceptable if enough resin is present to eliminate fiber show. The exterior surface shall be free of blisters larger than 0.5 inch in diameter, de-lamination or fiber show.
- F. Interior Surface: The interior surface shall be resin rich with no exposed fibers. The surface shall be free of crazing, de-lamination, blisters larger than 0.5 inch in diameter, and wrinkles of 0.125 inch or greater in depth. Surface pits shall be permitted if they are less than 0.75 inch in diameter and less than 0.0625 inch deep. Voids that cannot be broken with finger pressure and are entirely below the resin surface shall be permitted if they are less than 0.5 inch in diameter and less than 0.0625 inch thick.
- G. Wall Thickness: Fiberglass manholes 48" in diameter and up to 20 feet in depth will have a minimum wall thickness of 0.3125 inches. Fiberglass manholes 48 inches in diameter and 20 feet to 30 feet in depth will have a minimum wall thickness of 0.5 inches.
- H. Repairs: Any manhole repairs are subject to meet all requirements of this specification.

- I. Manhole Length: Manhole lengths shall be in 6-inch increments +/- 2 inches.
- J. Diameter Tolerance: Tolerance of inside diameter shall be +/- 1% of required manhole diameter.
- K. Load Rating: The complete manhole shall have a minimum dynamic-load rating of 16,000 lbs. when tested in accordance with A.S.T.M. 3753, 8.4 (note 1). To establish this rating the complete manhole shall not leak, crack, or suffer other damage when load tested to 40,000 lbs. and shall not deflect vertically downward more than 0.25 inch at the point of load application when loaded to 24,000 lbs.
- L. Stiffness: The manhole cylinder shall have the minimum pipe-stiffness values shown in the table below when tested in accordance with A.S.T.M. 3753, 8.5 (note 1).

<u>LENGTH - FT.</u>	<u>F/AY - PSI</u>
3 - 6.5	0.75
7 - 12.5	1.26
13 - 20.5	2.01
21 - 25.5	3.02
26 - 35	5.24

- M. Soundness: In order to determine soundness, the manufacturer shall apply an air or water pressure test to the manhole test sample. Test pressure shall not be less than 3 psig or greater than 5 psig. While holding at the established pressure, inspect the entire manhole for leaks. Any leakage through the laminate is cause for failure of the test. Refer to A.S.T.M. D-3753, 8.6.
- N. Chemical Resistance: The fiberglass manhole and all related components shall be fabricated from corrosion proof material suitable for atmospheres containing hydrogen sulfide and dilute sulfuric acid as well as other gases associated with the wastewater collection system.

2.3 PHYSICAL PROPERTIES

	<u>Hoop Direction</u>	<u>Axial Direction</u>
a. Tensile Strength (psi)	18,000	5,000
b. Tensile Modules (psi)	$0.6 \times 10^6$	$0.7 \times 10^6$
c. Flexural Strength (psi)	26,000	4,500
d. Flexural Modules (psi)	$1.4 \times 10^6$	$0.7 \times 10^6$
e. Compressive (psi)	18,000	10,000

2.4 TESTING

- A. All tests shall be performed as specified in A.S.T.M. D-3753 latest edition, Section 8, test method D-790 (See Note 5) and test method D-695.

2.5 QUALITY CONTROL

- A. Each completed manhole shall be examined by the manufacturer for dimensional requirements, hardness, and workmanship. All required A.S.T.M. D-3753 testing shall be completed and records of all testing shall be kept and copies of test records shall be presented to customer upon formal written request within a reasonable time period.

2.6 CERTIFICATIONS

- A. As a basis of acceptance the manufacturer shall provide an independent certification which consists of a copy of the manufacturer's test report and accompanied by a copy of the test results stating the manhole has been sampled, tested, and inspected in accordance with the provisions of this specification and meets all requirements.

## 2.7 SHIPPING & HANDLING

- A. Do not drop or impact the fiberglass manhole. Fiberglass manhole may be lifted by inserting a 4"x4"x30" timber into the top of manhole with cable attached or by a sling or "choker" connection around the center of manhole, lift as required. Use of chains or cables in contact with the manhole surface is prohibited.

## 2.8 MARKING & IDENTIFICATION

- A. Each manhole shall be marked on the inside and outside with the following information:
  - 1. Manufacturer's name or trademark
  - 2. Manufacturer's factory location
  - 3. Manufacturer's serial number
  - 4. Total manhole depth.

# PART 3 EXECUTION

## 3.1 INSTALLATION

- A. Closed Bottom Manhole Installation: Bottom of excavation should be compacted to 95% Standard Proctor Density. Manholes with diameters less than 60 inches and depths less than 12 feet require a base of 6 inches of crushed stone. Manholes with depths of 10 feet and greater, and diameters of at least 48 inches should have a poured reinforced concrete base at least one (1) foot deep and at least two (2) feet larger than fiberglass manhole outside diameter. The fiberglass manhole shall be lowered into the wet concrete and brought to plumb. Pour reinforced concrete over the anti-flotation flange. The concrete shall be a minimum of one (1) foot deep and two (2) feet from outside wall of the manhole. More concrete may be required in high water table areas. In high water table areas consult the Engineer for backfill requirements.
- B. Backfill Material: Unless shown otherwise on drawings and approved by the Engineer, sand, crushed stone, or pea gravel shall be used for backfill around the manhole for a minimum distance of one (1) foot from the outside surface and extending from the bottom of the excavation to the top of the reducer section. Suitable material chosen from the excavation may be used for the remainder of the backfill. The material chosen shall be free of large lumps or clods, which will not readily break down under compaction. This material will be subject to approval by the Engineer.
- C. Backfill Procedure: Backfill shall be placed in layers of not more than 12 loose measure inches and mechanically tamped to 95% Standard Proctor Density, unless otherwise approved by the Engineer. Flooding will not be permitted. Backfill shall be placed in such a manner as to prevent any wedging action against the fiberglass manhole structure.

END OF SECTION

## SP-4 TECHNICAL REQUIREMENTS AND SPECIFICATIONS

### FRP TEE BASE MANHOLES

---

#### PART 1 GENERAL

##### 1.1 SECTION INCLUDES

- A. Centrifugally Cast Reinforce Fiberglass Mortar Pipe (CCFRPM) and filament wound glass-reinforced polymer (GRP) pipe Tee Base Manholes

##### 1.2 REFERENCES

- A. ASTM D3262 Standard Specification for "Fiberglass (Glass-Fiber-Reinforced Thermosetting-Resin) Sewer Pipe"<sup>1,2</sup>
- B. ASTM D3753 Standard Specification for Glass-Fiber-Reinforced Polyester Manholes<sup>1</sup>
- C. ASTM D2412 Standard Test Method for Determination of External Characteristics of Plastic Pipe by Parallel-Plate Loading
- D. ASTM D3681 Standard Test Method for Chemical Resistance of (Glass-Fiber-Reinforced Thermosetting-Resin) Pipe in a Deflected Condition<sup>1</sup>
- E. ASTM D695 Standard Test Method for Compressive Properties of Rigid Plastics
- F. ASTM D638 Standard Test Method for Tensile Properties of Plastics
- G. ISO 9001:2015 Quality managements systems - Requirements

#### PART 2 PRODUCTS

##### 2.1 MATERIALS

- A. FRP tee base manholes shall be manufactured from commercial grade polyester resin or vinyl ester resins. Tee base manholes shall meet or exceed all specifications of ASTM D-3753 as manufactured by Hobas Pipe USA Inc. or Thompson Pipe Group, Inc. or an approved equal.
- B. Resin: The resin used shall be a commercial grade unsaturated polyester resin or vinyl ester resin. Resins shall be suitable for the service environment intended (i.e. domestic sanitary wastewater).
- C. Reinforcing Materials: The reinforcing material shall be commercial grade "E" type glass in the form of mat, chopped roving, roving fabric, or both, having a coupling agent that will provide a suitable bond between the glass reinforcement and the resin.
- D. Riser and Cones: Riser pipe shall be manufactured per ASTM D3262 with cone manufactured of similar materials.
- E. Interior Surfacing Material: The inner surface of the riser pipe exposed to the environment shall have a resin rich non-reinforced layer (nominal 40 mils in thickness) to resist abrasion and crack resistance.
- F. Fillers and Additives: Fillers, when used, shall be inert to the environment and manhole construction. Additives, such as thixotropic agents, catalyst, promoters, etc., may be added as required by the specific manufacturing process to be used to meet the requirements of the referenced ASTM standards.
- G. Exterior Surface:

- 1) Cones – Exterior surface shall be coated with suitable gel coat as an additional UV and water barrier. Gel coat shall be pigmented to resist ultraviolet. The exterior surface shall be relatively smooth with no sharp projections free of blisters, de-laminations or exposed fiberglass. Indentations or other shape imperfections that will not affect performance are allowed.
- 2) Riser Sections and Tee-bases – Exterior will be constructed of a sand rich layer without reinforcing glass to provide UV resistance.

H. Manhole Top Configuration:

- 1) Cone Sections – The manhole reducer must provide a bearing surface on which a standard ring and cover may be supplied and adjusted to grade. The reducer shall be concentric and shall be joined to the barrel section at the factory with resin and glass fiber reinforcement, thus providing required monolithic design to prevent infiltration and/or exfiltration through the manhole.

I. Class: The manhole shall be manufactured in one class of load rating. This class shall have a minimum HS-20-wheel load (16,000 pounds dynamic wheel load).

J. Connections and Stub outs:

- 1) Inlet and outlets connections will be made of CCFRPM or GRP pipe material that is laminated to CCFRPM or GRP riser pipe and shipped with one spigot end (outlet) and one FWC coupling and (inlet) unless otherwise directed by the purchaser.
  - a. Identified PVC or FRP branch connections will be cored and attached to the manhole riser with fiberglass laminations at the design engineer's flow line elevations, vertical and horizontal angles. All small diameters lateral stub-outs to be furnished as plain end (spigot).
  - b. Field connections of 4"-15" PVC lines can be accomplished with Insert-a-Tee connectors or engineer approved equal.

K. Manhole Bottom:

- 1) Resin and glass reinforced manhole bottoms will be provided with a glass reinforced bottom section with integral FWC coupling for watertight attachment to FRP tee-base riser neck.
- 2) Full bench and invert manholes will have a bench manufactured utilizing non-corrosive materials encapsulated in fiberglass minimum ¼" thick.

## 2.2 MANUFACTURE AND CONSTRUCTION

- A. Manhole cylinders, manway reducers, and joints shall be produced from fiberglass reinforced polyester resin using a combination of centrifugal casting, continuous winding, or spray process. Tee Base-Connection: Fiberglass manhole risers shall be joined to a pipe stub rising vertically from in-line tee fitting. Manhole risers shall be connected to the vertical pipe using an FWC pipe coupling cast into the bottom of the fiberglass riser. Pipe coupling shall seal to the tee-base using a flexible compression gasket compatible with the tee-base pipe material. Pipe coupling shall be permanently bonded into the base of the riser using fiberglass laminate. Pipe coupling shall be joined to the in-line tee fitting by placing the manhole riser on top of the tee outlet and applying downward pressure

until the vertical pipe stub is inserted into the pipe coupling to the proper depth. See homing line mark on tee base branch (neck) for depth of penetration into FWC coupling.

- B. Dimensions: The tee base manhole shall be a circular cylinder, reduced at the top to a circular manway not smaller than 30" inside diameter. Manholes shall be produced in half-foot increments in lengths +/- 2". The nominal inside diameter of the riser section shall be 60".
- C. Diameter Transition: Individual fiberglass components of manhole shall be joined by fiberglass reinforced laminations or be fiberglass bonded.
- D. Anti-Flotation Flange: Exterior of manhole riser shall incorporate a 3" minimum wide flange at its base. Upon joining of manhole riser to pipe tee, sufficient concrete shall be poured around tee and manhole riser to prevent buoyancy. Anti-flotation flange shall be encased with 12" of concrete (minimum), in addition to the 10" of concrete (minimum) above the top of pipe as required for the tee base concrete encasement height.
- E. Concrete Encasement: The minimum width of the concrete encasement shall be the width of the pipe plus 2' on both sides of pipe. Concrete shall have a compressive strength of 5,000 PSI.
- F. Height Adjustment: Fiberglass manholes shall be height adjustable using external grade rings or adjustment with an FWC coupling riser joint. Top riser sections can be cut for height adjustment and shall be rejoined with an FWC coupling.
- G. Ring and Cover Platform: Top of cone/reducer shall have a fiberglass support platform upon which grade rings may be installed to accept a typical cast iron ring and cover. Grade rings, ring and cover shall be placed over fiberglass neck (chimney) in a manner that evenly distribute loading onto grade rings only. No loading shall be placed onto fiberglass neck.
- H. Repairs: Any manhole repair is required to meet all requirements of this specification.
- I. Manhole Riser Lengths: Riser lengths shall be in whole or 1/2-foot increments +/- 2".
- J. Load Rating: The complete manhole riser shall have a minimum dynamic load rating of 16,000 lbf (71 172 N) when tested in accordance with ASTM D3753, 8.4. To establish this rating the complete manhole shall not leak, crack, or suffer other damage when load tested to 40,000 lbf (71 929 N) and shall not deflect vertically downward more than 0.25 in. (6.35 mm) at the point of load application when loaded to 24,000 lb. (106 757 N).
- K. Stiffness: The cylindrical portion of the manhole riser is to be tested in accordance with ASTM Method D2412. The riser cylinder shall have the minimum pipe-stiffness values shown in the table below, when tested in accordance with ASTM D3753, Section 8.5.

3'-6'	46psi
7'-12'	46psi
13'-20'	46psi
21'-25'	46psi
26'-35'	46psi

- L. Soundness: In order to determine soundness, an air or water test is to be applied to the manhole riser test sample. While holding the pressure between 3-5psi, the entire manhole riser must be inspected for leaks. Any

leakage through the laminate is cause for failure of the test. Refer to ASTM D3753, Sec. 8.6. Manufacturer to provide documentation of previous test per ASTM D3753 Sec. 8.6.

- M. Chemical Resistance: Riser pipe shall meet the chemical testing outlined in ASTM D3262 when tested in accordance with ASTM D3681. Cones shall be manufactured with similar materials.

### 2.3 TESTING

- A. All test shall be performed as specified in ASTM D3753, Section 8, Titled "Test Methods". See ASTM D3753, Section 8, Note 5, for test method D790 and test method D-695.

### 2.4 QUALITY CONTROL

- A. Examinations: Each Manhole riser component part shall be examined for dimensional requirements, hardness, and workmanship.
- B. Composition Control: Controls on glass and resin content shall be maintained for all manufacturing processes and for each portion of the manhole riser fabrication. Records shall be maintained for these control checks. Proper glass content may be shown by glass usage checks or glass and resin application rate checks, in accordance with the material composition test in ASTM D375.

### 2.5 CERTIFICATIONS

- A. As a basis of acceptance the manufacturer shall provide an independent certification which consists of a copy of the manufacturer's test report and accompanied by a copy of the test results stating the manhole has been sampled, tested, and inspected in accordance with the provisions of this specification and meets all requirements.

### 2.6 MARKING & IDENTIFICATION

- A. All manholes shall be marked with the following information:
  - 1) Manufacturer's name
  - 2) Riser vertical height
  - 3) ASTM D3753 Designation
  - 4) Station number or manhole ID, per project plans.

## **SP-5 TECHNICAL REQUIREMENTS AND SPECIFICATIONS**

### **COMPOSITE MANHOLE FRAME & COVER**

---

#### **PART 1 GENERAL**

##### **1.1 MATERIAL**

- A. Composite manhole frame and cover shall be made of a fiber reinforced polymer using at least 45% fiber reinforcement and thermoset resin matrix.

##### **1.2 USABILITY**

- A. Composite unit must facilitate easy removal of the cover by one person, have a 750:1 strength to weight ratio and possess no possibility of corrosion welding between the frame and cover.
- B. Composite unit shall have an integrated gasket system to reduce traffic shock, noise, and odors.
- C. Composite unit shall have Stainless Steel quarter turn paddle lock.

##### **1.3 PEDESTRIAN SAFETY**

- A. Composite unit shall be heat insulating, non-conductive, and provide skid slip performance of 0.6 according to ASTM C1028.

##### **1.4 LOAD CARRYING CAPACITY**

- A. AASHTO M306-10 H-20 & H-25 traffic requirements of 50,000 lbs., with 100,000lb ultimate load bearing.

##### **1.5 FATIGUE PERFORMANCE**

- A. Must pass 2 million cycles at 16,000 lbs. and then proof load requirements U.S. AASHTO M306-10 H-20 & H-25 or EN 124 Class A-D.

##### **1.6 MARKINGS**

- A. AASHTO M306-10
- B. Country of origin

##### **1.7 QUALITY & WARRANTY STATEMENT**

- A. Manufacturer must provide a warranty for the composite unit for 5 years.
- B. Composite manhole frame and cover must be made in the USA.

##### **1.8 ACCEPTABLE MANUFACTURERS**

- A. EJ - Model 3200 or Pre-Approved Equivalent

END OF SECTION

**SP-6 TECHNICAL REQUIREMENTS AND SPECIFICATIONS**  
**MANHOLE AND CATCH BASIN GRADE ADJUSTING RING**  
**SPECIFICATION**

---

PART 1      GENERAL

1.1      SCOPE

This specification defines the materials required for the adjustment of all manholes, catch basins or other underground utility structures to final elevation as shown on the project drawings.

1.2      WORK REQUIRED

Grade adjustment rings meeting the requirements of this section shall be used to adjust and support the frame and cover or grate to the specified final elevation on all manholes, catch basin or other utility structures.

a.      SYSTEM DESCRIPTION

A. Design Requirements – The grade adjustment rings shall be designed to allow final adjustment of the frame and cover or grate to the grade established by the ENGINEER on the project drawings. The rings shall also be designed to accommodate flat or sloping surfaces to within approximately ¼" (one quarter inch) to ½" (one half inch) of the specified final elevation. The grade adjustment system shall have a minimum 50 (fifty) year design life.

B. Performance Requirements – The grade adjustment rings shall be capable of supporting the minimum requirements of AASHTO M-306, H-25 and HS-25, be UV stable and be resistant to chemicals and corrosion commonly associated with the sanitary and storm sewer environments.

b.      SUBMITTALS

A. Test Report – A test report from an approved third party testing agency showing the grade adjustment rings meets the minimum requirements of AASHTO M-306, H-25 and HS-25.

B. Certification – The manufacturer of the grade adjustment rings shall provide certification to the ENGINEER stating that the product meets the design life and material requirements of this specification.

PART 2      PRODUCTS

2.1      MANHOLE AND CATCH BASIN GRADE ADJUSTMENT RING

Manhole and catch basin grade adjustment rings shall consist of a variety of heights (thicknesses), diameters and shapes all conforming to the following requirements:

A. Grade Adjustment Rings – The grade adjustment rings shall be manufactured from ARPRO® Expanded Polypropylene (EPP), black, 5000 series meeting ASTM D3575 and ASTM D4819-13; B6D7G4L3M<sub>2</sub>4S2T<sub>1</sub>7W7. The rings shall be manufactured using a high

compression molding process to produce a finished density of 120 g/l ((7.5 pcf).

B. "Grade" adjustment rings may contain either an upper and lower keyway (tongue and groove) for vertical alignment and/or an adhesive trench on the underside with a flat top.

C. "Finish" or "Flat" rings may either have a keyway (groove) on the underside for vertical alignment and/or an adhesive trench with a flat upper surface. These rings shall be available in heights (thicknesses) which will allow final adjustment of the frame and cover or grate to within ¼" (one quarter inch) to ½" (one half inch) of the specified final elevation.

"Finish" rings may also have a keyway on the upper surface of the inner diameter to facilitate installation of an "Angle" ring.

D. "Angle" rings may either have an upper and lower keyway (tongue and groove) for vertical alignment and/or an adhesive trench on the underside. When required, the "Angle" ring or rings shall allow final adjustment of the frame and cover or grate to within ¼" (one quarter inch) to ½" (one half inch) of the specified final elevation.

E. Acceptable Manufacturer – PRO-RING™ by Cretex Specialty Products

## 2.2 EQUIPMENT

The contractor shall have the required tools and equipment necessary to facilitate proper installation of the grade adjustment rings.

## 2.3 ADHESIVE/SEALANT

A. Any adhesive or sealant used for watertight installation of the manhole grade adjustment rings shall be M-1 Structural Adhesive/Sealant or equal meeting the following specifications:

ASTM C-920, Type S, Grade NS, Class 25, Uses NT, T, M, G, A and O

Federal Specification TT-S-00230-C Type II, Class A

Corps of Engineers CRD-C-541, Type II, Class A

Canadian Standards Board CAN 19, 13-M82

AAMA 802.3-08 Type II, AAMA 803.3-08 Type I and AAMA 805.2-08 Group C

B. Other adhesives or sealants may only be used with engineer or owner's written authorization.

## 2.4 REPAIR MORTAR

A. Repair mortar shall be a one component, quick set, high strength, non-shrink; polymer modified cementitious patching mortar, which has been formulated for vertical or overhead use meeting the requirements of ASTM C-109 for Compressive Strength, C-348 and C-78 for Flexural Strength and C-882 for Slant Shear Bond Strength. Repair mortar shall not contain any chlorides, gypsums, plasters, iron particles, aluminum powder or gas-forming agents nor shall it promote the corrosion of any steel that it may come in contact with.

B. Acceptable Manufacturers

1. Octocrete by IPA Systems

2. Pre-Approved Equal

## 2.5 CEMENTITIOUS GROUT

A. Cementitious grout shall be a premixed, non-metallic, high strength, non-shrink grout which meets the requirements of ASTM C-191 and C-827 as well as CRD-C-588 and C-621. When mixed to a mortar or "plastic" consistency, it shall have minimum one day and 28 day compressive strength of 6,000 and 9,000 psi, respectively.

B. Acceptable Manufacturers

1. PennGrout by IPA Systems

2. Pre-Approved Equal

## PART 3 EXECUTION

### 3.1 INSTALLATION

Installation and surface preparation shall be in accordance with the manufacturer's instructions.

The joint between the first grade ring and top of the manhole, catch basin or utility structure shall be sealed using an adhesive/sealant meeting the requirements of Section 2.03.

If the top of the manhole, catch basin or utility structure is not level or is irregular, then a non-shrink repair mortar meeting the requirements of Section 2.04 or non-shrink cementitious grout meeting the requirements of Section 2.05 shall be used. A bed the specified mortar or grout shall be placed on the top surface of the utility structure and then the first grade ring shall be embedded and leveled into the bed of material.

The remaining joints between all manhole adjustment rings and the frame and cover or grate shall be sealed using an adhesive/sealant meeting the requirements of Section 2.03.

No other materials shall be used in the construction of the grade adjustment area beyond those specified above. Prohibited materials include, but are not limited to wood or wood shims of any kind, concrete, brick, block, stones, etc.

The use of any heat shrinkable chimney seals shall only be permitted with engineer or owner's written authorization.

## SP-7 TECHNICAL REQUIREMENTS AND SPECIFICATIONS

### LARGE DIAMETER POLYVINYL CHLORIDE (PVC) GRAVITY SEWER PIPE AND FITTINGS

---

---

PART 1 GENERAL

- 1.1 SECTIONS INCLUDES  
Polyvinyl chloride (PVC) sewer pipe and fittings for gravity sanitary sewers in nominal diameters 18 inches through 60 inches.
- 1.2 REFERENCES  
ASTM D1784 - Standard Specification for Rigid Polyvinyl Chloride Compound and Chlorinated Polyvinyl Chloride Compounds.  
ASTM D2321 - Practice for Underground Installation of Flexible Thermoplastic Sewer Pipe.  
ASTM D2444 - Test Method for Impact Resistance of Thermoplastic Pipe and Fittings by Means of a Tup (Falling Weight).  
ASTM D3212 - Specification for Joints for Drain and Sewer Plastic Pipes Using Flexible Elastomeric Seals.  
ASTM F477 - Standard Specification for Elastomeric Seals (Gaskets) for Joining Plastic Pipe.  
ASTM F679 - Specification for Polyvinyl Chloride Large-Diameter Plastic Gravity Sewer Pipe and Fittings.  
ASTM F1417 - Standard Practice for Installation Acceptance of Plastic Non-pressure Sewer Lines using Low-Pressure Air

PART 2 PRODUCTS

MATERIALS

- A. Use PVC compounds in the manufacture of pipe that contain no ingredient in an amount that has been demonstrated to migrate into water in quantities considered to be toxic.
- B. Gravity Sanitary Sewer Pipe:
1. Pipe shall conform to ASTM F 679 with wall thickness as required for a pipe strength of 75 psi.
- C. Joints:
1. Spigot and integral wall section bell with solid cross section elastomeric or rubber ring gasket conforming to requirements of ASTM D 3212 and ASTM F 477. Gaskets shall be factory-assembled and securely bonded in place to prevent displacement. The manufacturer shall test a sample from each batch conforming to requirements ASTM D 2444.
- D. Gaskets:
1. Gaskets shall meet the requirements of ASTM F 477. Use elastomeric factory-installed gaskets to make joints flexible and watertight.
  2. Lubricant for rubber-gasketed joints: Water soluble, non-toxic, non-objectionable in taste and odor imparted to fluid, non-supporting of bacteria growth, having no deteriorating effect on PVC or rubber gaskets.

E. Fittings:

1. Provide PVC gravity sewer sanitary bends, tee, or wye fittings for new sanitary sewer construction. PVC pipe fittings shall be full-bodied, either injection molded or factory fabricated. Saddle-type tee or wye fittings are not acceptable.

CUSTOMER INSPECTION

- F. The Owner or other designated representative shall be entitled to inspect pipes or witness the pipe manufacturing.
- G. Should the Owner request to see specific pipes during any phase of the manufacturing process, the manufacturer must provide the Owner with adequate advance notice of when and where the production of those pipes will take place

PACKAGING, HANDLING, SHIPPING

- A. Packaging, handling, and shipping shall be done in accordance with the manufacturer's instructions.

PART 3 EXECUTION

3.1 PROTECTION

- A. Store pipe under cover out of direct sunlight and protect from excessive heat or harmful chemicals in accordance with the manufacturer's recommendations.

3.2 INSTALLATION

- A. Install PVC pipe in accordance with ASTM D 2321 and manufacturer's recommendations.
- B. Avoid imposing strains that will overstress or buckle the pipe when lowering pipe into trench.
- C. Hand shovel pipe bedding under the pipe haunches and along the sides of the pipe barrel and compact to eliminate voids and ensure side support.
- D. Burial: The bedding and burial of PVC pipe and fittings in non-paved areas outside of City right-of-way shall be in accordance with the Drawings
- E. Pipe Handling: Use textile slings, other suitable materials or a forklift. Use of chains or cables is not recommended.

3.3 FIELD TESTS

- A. Low Pressure Air Test: After installation of the pipe, each reach shall be tested with the method as outlined in City of Tulsa Standard Specification Section 408.11. The low pressure air test shall be done in accordance with ASTM F1417. To pass the low pressure air test, the allowable limit is equal to or less than 10 gallons per inch of pipe diameter per mile per day at 2 feet of head as required by OAC 252:656-5-5(b).
- B. Deflection: Perform deflection tests on all pipe after the final backfill has been in place at least 30 days. Maximum allowable long-term deflection shall not exceed 5% of the average initial diameter. Tests shall be performed using a rigid ball or mandrel with a diameter equal to 95% of the average inside diameter of the pipe taking into consideration manufacturing tolerances. Tests shall be performed without mechanical pulling devices. The deflection test shall be done in accordance with ASTM F679.

- C. CCTV Inspection: After installation of the pipe, Contractor shall contact Field Engineering staff to request scheduling for Sewer Operations & Maintenance to TV inspect the line as specified in City of Tulsa Standard Specifications.
- D. All field tests shall be scheduled and coordinated with the Engineer.

END OF SECTION

## **SP-8 TECHNICAL REQUIREMENTS AND SPECIFICATIONS**

### **MODIFICATION TO CITY OF TULSA STANDARD SPECIFICATION 301 RIGHT-OF-WAY CLEARING AND RESTORING**

---

#### **PART 301 - RIGHT-OF-WAY CLEARING AND RESTORING**

The following modification(s) shall replace the referenced specification section located in the City of Tulsa Standard Specifications and Standard Details, Dated March 2022.

301.4 PAYMENT: Payment for this item shall be made at the unit price bid per square yard. Area shall be computed as follows: total length of pipe, not including bores, fittings, or specials, as included in other items; and standard width of right-of-way clearing and restoring of a maximum pay limit width of fifty linear feet. No additional payment shall be made for alterations of utility mains, service lines, or appurtenances, unless specifically provided for elsewhere in the Contract Documents.

**END OF SECTION**

**SP-9 TECHNICAL REQUIREMENTS AND SPECIFICATIONS**  
**REMOVED FROM SPECIAL PROVISIONS**

---

PART 1      GENERAL

1.1      This section has been removed from the Special Provisions.

END OF SECTION

## SP-10 TECHNICAL REQUIREMENTS AND SPECIFICATIONS

### SANITARY SEWER CONSTRUCTION FORM

---

#### PART 1 GENERAL

- 1.1 Contractor shall complete one (1) Sanitary Sewer Construction Form for each sanitary sewer line that has been rehabilitated or constructed on this project. Sample forms may be obtained from City of Tulsa Sewer Operations.
- 1.2 Contractor shall submit forms for all sanitary sewer lines completed with each monthly payment request.
- 1.3 Sanitary Sewer Construction Form shall contain at minimum the follow information.
  - a. Project number
  - b. Project name
  - c. Contractor name
  - d. Pay Application number
  - e. Upstream manhole number
  - f. Downstream manhole number
  - g. Footage of pipe measured from manhole to manhole
  - h. Type of rehabilitation or construction method
  - i. New pipe size and material
  - j. Date completed
  - k. Service connection information as follows for each connection
    - i. Property address served
    - ii. Measurement from downstream manhole
    - iii. Clock position of connection
    - iv. Active service or capped for future service
    - v. Type of service connection at main
    - vi. Footage of service pipe installed by contractor from sewer main
    - vii. Size and material of service pipe
    - viii. Type of coupling utilized to connect to customer's existing service pipe
    - ix. Size and material of customer's existing service pipe
    - x. Depth of contractor's connection to customer's existing service pipe.
- 1.4 No additional payment will be made for completion of Sanitary Sewer Construction Form.

END OF SECTION

**SP-11 TECHNICAL REQUIREMENTS AND SPECIFICATIONS**  
**SANITARY SEWER BYPASS PUMPING NOTIFICATION**

---

PART 1      GENERAL

1.1      SCOPE

Contractor is required to submit written bypass pumping notifications form to Sewer Operations and Maintenance at least one week prior to bypass pumping. The notification form is to be submitted via email to [SOMDispatch@cityoftulsa.org](mailto:SOMDispatch@cityoftulsa.org).

**Maintenance WATER AND  
SEWER DEPARTMENT  
Sanitary Sewer By-Pass Pumping  
Notification**

Contractor: \_\_\_\_\_ Project: \_\_\_\_\_

Inspector: \_\_\_\_\_ Inspector Phone: \_\_\_\_\_

City Engineer \_\_\_\_\_ City Eng Phone: \_\_\_\_\_

By-Pass Pumping Start Date \_\_\_\_\_ Expected End Date: \_\_\_\_\_

Address: \_\_\_\_\_

Pump will be installed in manhole #: \_\_\_\_\_ Pump will discharge to manhole #: \_\_\_\_\_

**Plan for pump operation to prevent sewage overflows:**

How will pump be monitored after hours to ensure no pumping disruption?

**After-hour contact information for Contractor:**

Primary

Name: \_\_\_\_\_ Number(s): \_\_\_\_\_

Secondary

Name: \_\_\_\_\_ Number(s): \_\_\_\_\_

1. Form should be emailed to the Sewer Operations personnel at [SOMDispatch@cityoftulsa.org](mailto:SOMDispatch@cityoftulsa.org), **1-week prior to by-pass pumping event.**
2. Attach to this notification any approved by-pass pumping submittals.
3. If advanced notice cannot be given, form should be emailed immediately after beginning by-pass pumping and Emergency Sewer Response at 918-586-6999 should be contacted.

In the event of sewage overflow or any other emergency while by-pass pumping,  
**call Emergency Sewer Response at 918-586-6999 for 24-Hour Service.**

## SP-12 TECHNICAL REQUIREMENTS AND SPECIFICATIONS

### PIPE CULVERTS AND CULVERT END TREATMENTS

---

---

#### PART 1 GENERAL

##### 1.1 SUMMARY

- A. This specification covers all labor, materials, equipment, and services necessary to complete the installation of pipe culverts and culvert end treatments.

##### 1.2 REFERENCES

- A. ASTM F2881 – Standard Specification for 12 to 60 in. Polypropylene (PP) Dual Wall Pipe and Fittings for Non-Pressure Storm Sewer Applications
- B. AASHTO M330 – Standard Specification for Polypropylene Pipe, (12 to 60 in.) Diameter
- C. Oklahoma Department of Transportation (ODOT) – 2019 Standard Specifications

##### 1.3 MATERIAL

###### A. PIPE CULVERTS

- 1. The contractor shall use ADS HP Storm pipe, a dual wall polypropylene pipe, or an engineer approved equivalent. The pipe culverts shall conform to ASTM F2881 or AASHTO M330, ODOT specification number 613(EE), and be suitable for HS-20 loading.

###### B. SINGLE PIPE CULVERT END TREATMENTS

- 1. The single pipe culvert end treatments shall conform to ODOT specification number 613(M). The culvert end treatments shall match ODOT sheet number R-26 and standard detail CET4S-3.

###### C. DOUBLE PIPE CULVERT END TREATMENTS

- 1. The double pipe culvert end treatments shall conform to ODOT specification number 613(M). The culvert end treatments shall match ODOT sheet number R-28 and standard detail CET4D-3.

###### D. REINFORCED RUBBERIZED MASTIC BANDS

- 1. The contractor shall use MarMac Dissimilar pipe coupler, or an engineer approved equivalent. The coupler shall be used to join the polypropylene pipe and culvert end treatment.

##### 1.4 CULVERT END TREATMENT TYPES

- A. Single Pipe Installation Culvert End Treatment shall be constructed as type A4 for an 18-inch round pipe as shown in ODOT sheet number R-26 and standard detail CET4S-3.
- B. Double Pipe Installation Culvert End Treatment shall be constructed as type AA4 for two (2) 18-inch round pipes as shown in ODOT sheet number R-28 and standard detail CET4D-3.

END OF SECTION

# SP-13 TECHNICAL REQUIREMENTS AND SPECIFICATIONS

## STEEL FRAME GATES

---

### PART 1 GENERAL

#### 1.1 SUMMARY

A. This specification covers all labor, materials, equipment, and services necessary to complete the installation of steel frame gates.

#### 1.2 MATERIAL

A. The entirety of the gate shall be steel frame.  
B. The gate shall be connected and supported by metal posts. Wood posts shall not be installed.

#### 1.3 DIMENSIONS

A. Steel Frame Gates shall be 16-foot width and 50-inch height. Number of cross bars shall be a minimum of five (5) and gauge weight of the steel minimum 19 gauge.  
B. Post height dimension shall be the same as required for adjacent existing fence.

#### 1.4 SUBMITTALS

A. Product Data:  
1. Technical data sheet on each product used.

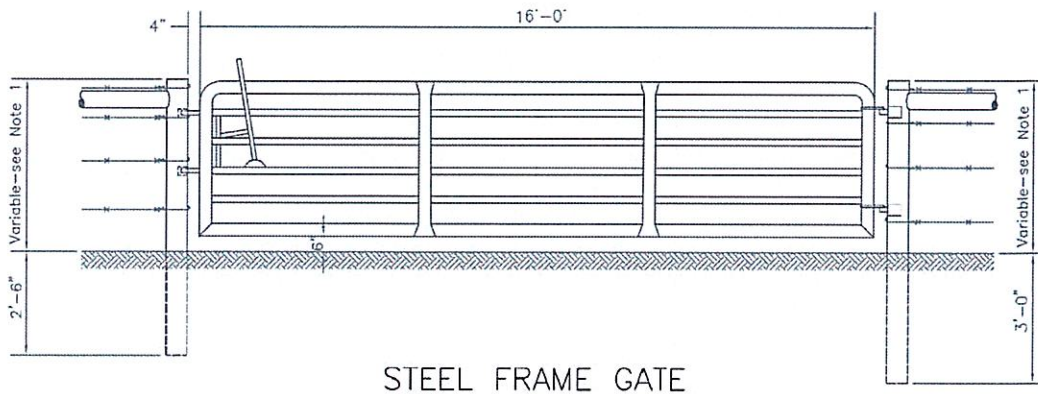

## SP-14 TECHNICAL REQUIREMENTS AND SPECIFICATIONS

### GEOTEXTILE REINFORCEMENT

---

#### PART 1 GENERAL

1. The geogrid is manufactured from a punched polypropylene sheet, which is then oriented in three substantially equilateral directions so that the resulting ribs shall have a higher degree of molecular orientation, which continues at least in part through mass of integral node.
2. The properties contributing to the performance of a mechanically stabilized layer include the following:

<b>Index Properties</b>	<b>Longitudinal</b>	<b>Diagonal</b>	<b>Transverse</b>	<b>General</b>
Rib Pitch (in.)	1.60	1.60		
Mid-rib depth (in.)		1.30	1.20	
Mid-rib width (in.)		0.90	1.20	
Rib shape				Rectangular
Aperture shape				Triangular

3. The geotextile reinforcement shall be Tensar TriAx TX5 Geogrid or Engineer approved equivalent. The geogrid shall be delivered to the jobsite in roll form with each roll individually identified and nominally measuring 10 feet or 13 feet width.

## **SP-15 TECHNICAL REQUIREMENTS AND SPECIFICATIONS**

### **STONE CREEK FARMS LIFT STATION ABANDONMENT**

---

---

#### **PART 1 GENERAL**

##### **1.1 SUMMARY**

- A. This section covers the demolition of existing piping, equipment, and sitework and the salvage of existing material and equipment as indicated on the Construction Drawings. All structures and facilities of the existing lift station that are not to be removed must remain in continuous operation during the proposed work. Demolition and salvage work shall create minimal interference with the Owner's operations and minimal inconvenience to the Owner. Blasting will not be permitted.

##### **1.2 DEMOLITION**

###### **A. Project Demolition**

1. Refer to Construction Drawings for site demolition. Contractor is to protect the existing onsite structures, electrical, water, and other services during demolition. Refer to the Demolition Plan for demolition notes.
2. All miscellaneous materials shall be removed from structures and disposed of off-site by the Contractor. This includes grating, pipe supports, handrails, ladders, doors, door frames, window frames, and other related items.
3. All surface and buried items associated with the proposed structure and service shall be removed outside of the bottom of the wet well and wash basin. Contractor shall remove the top ten (10) vertical feet of the wet well and valve vault structures. This also includes disconnecting public and private utility connections to the existing lift station.
4. The demolition of the existing lift station shall not occur until after the gravity sanitary sewer interceptor is constructed, approved, and operational to minimize disruption of service to the public.

###### **B. Piping and Equipment Demolition – The following piping and equipment shall be removed and shall become the property of Contractor. All such items shall be promptly removed from the jobsite.**

1. Existing valves and pump equipment not salvaged by the City and other related process and electrical equipment, as shown on the Construction Drawings.
2. Excluding items identified in the Demolition Section 1.3 Salvage or shown on the Construction Drawings, demolition shall include

pumps, piping, wire-conduits to the extent possible, electrical cabinets, valves, equipment, related process items, electrical equipment, and appurtenances being demolished.

- C. Sitework Demolition shall include the following, as indicated on the drawings:
  - 1. Removal of asphalt surface, concrete sidewalks, electrical duct, curbs, fencing, cable guards, trees, shrubs, and other miscellaneous structures within the limits of the proposed grading as shown on the Construction Drawings.

### 1.3 SALVAGE

- A. Items To Be Salvaged by Owner – Contractor shall coordinate with the Owner's Representative to identify any Owner salvage items, if any. Contractor will remove, package, and deliver to the Sewer Operations and Maintenance Department. Larger items, like valves and fittings, should be palletized and delivered to the Sewer Operations and Maintenance Department.

Items identified to be salvaged include:

- a. Generator
  - b. Pumps
  - c. Electrical Controls
- B. Items To Be Salvaged by Contractor - Removed and salvaged equipment or facilities shall include removal and salvage of all accessories, piping, wiring, supports, associated electrical starters and devices, baseplates and frames, and all other appurtenances, unless otherwise directed.
  - C. Existing Materials and equipment removed, and not reused as a part of the work, shall become the Contractor's property unless otherwise specified, and shall be removed from the jobsite.

### 1.4 ABANDONMENT

- A. The contractor shall remove the top ten (10) vertical feet of wet well and valve vault and fill the remaining structures with cellular concrete or flowable fill.

1.5 PAYMENT

- A. Payment for demolishing and abandoning the Stone Creek Farms Lift Station shall include the removal of asphalt, slide gate, fence, control building and its foundation, top ten (10) vertical feet of the wet well and valve vault, and fill the remaining structures with cellular concrete or flowable fill, and all required and necessary work to complete the demolition and abandonment. No additional payment shall be made for items of work not explicitly stated in the Construction Drawings that are associated with the demolition and abandonment. Items that are salvaged shall be delivered to the Owner at no additional cost.

END OF SECTION

## SP-16 TECHNICAL REQUIREMENTS AND SPECIFICATIONS

### ARTICULATED CONCRETE BLOCK MATTING

---

PART 1 PART 1 GENERAL

1.1 SUMMARY

A. The contractor shall furnish all labor, materials, equipment, and incidentals required for, and perform all operations in connection with, the installation of the ArmorFlex® Articulating Concrete Block (ACB) system in accordance with the lines, grades, design and dimensions shown on the Contract Drawings and as specified herein.

1.2 MATERIALS

A. Articulating Concrete Blocks

1. Manufacturing shall conform to the current version of ASTM D-6684, *Standard Specification for Materials and Manufacture of Articulating Concrete Block (ACB) Revetment Systems*.
2. Cementitious Materials - Materials shall conform to the following applicable ASTM specifications:
  - a. Portland Cements - Specification C 150, for Portland Cement.
  - b. Blended Cements - Specification C 595, for Blended Hydraulic Cements.
  - c. Hydrated Lime Types - Specification C 207, for Hydrated Lime Types.
  - d. Pozzolans - Specification C 618, for Fly Ash and Raw or Calcined Natural Pozzolans for use in Portland Cement Concrete.
  - e. Aggregates - Specification C 33, for Concrete Aggregates, except that grading requirements shall not necessarily apply.
3. Casting: The ACB units shall be produced using a dry cast method. Dry cast units obtain strength more quickly than wet cast blocks and will also achieve a greater uniformity of quality and greater durability.
4. Physical Requirements: At the time of delivery to the work site, the ACB units shall conform to the physical requirements prescribed in Table listed below.

PHYSICAL REQUIREMENTS

Compressive Strength Net Area Min. p.s.i (mPa)		Water Absorption Max. lb/ft <sup>3</sup> (kg/m <sup>3</sup> )	
Avg. of 3 units	Individual Unit	Avg. of 3 units	Individual Unit
4,000 (27.6)	3,500 (24.1)	9.1 (160)	11.7 (192)

5. Visual Inspection

- a. All units shall be sound and free of defects which would interfere with the proper placement of the unit, or which would impair the performance of the system. Surface cracks incidental to the usual methods of manufacture, or surface chipping resulting from customary methods of handling in shipment and delivery, shall not be deemed grounds for rejection.
- b. Cracks exceeding 0.25 inches (.635 cm) in width and/or 1.0 inch

(2.54 cm) in depth shall be deemed grounds for rejection. Chipping resulting in a weight loss exceeding 10% of the average weight of a concrete unit shall be deemed grounds for rejection.

- c. Blocks rejected prior to delivery from the point of manufacture shall be replaced at the manufacturer's expense. Blocks rejected at the job site shall be repaired with structural grout or replaced upon request at the expense of the contractor.

6. Sampling and Testing

- a. The purchaser (or their authorized representative) shall be afforded access to the relevant manufacturing facility or facilities, if desired, in order to inspect and/or sample the ACB units from lots ready for delivery prior to release for delivery to the job site. Such inspections are at the sole expense of the requesting entity.
- b. Purchaser may request additional testing other than that provided by the manufacturer as needed. Such requested testing will extend any stated lead times for manufacturing and delivery, if the results of such testing are a prerequisite to approval (i.e., approval for release to manufacturing). Costs associated with such testing shall be borne by the purchaser.

B. Revetment Cables and Fittings

1. Option 1. Polyester Revetment Cable and Fittings

- a. Revetment cable shall be constructed of high tenacity, low elongating, and continuous filament polyester fibers. Cable shall consist of a core construction comprised of parallel fibers contained within an outer jacket or cover.
- b. The size of the revetment cable shall be selected such that the minimum acceptable strength is at least five (5) times that required for lifting of the mats, in accordance with ASTM D-6684 paragraph 5.5.2. This design shall include a reduction factor for splicing of 60%, unless a larger factor can be substantiated by laboratory testing.
- c. The revetment cable shall exhibit resistance to most concentrated acids, alkalis and solvents. Cable shall be impervious to rot, mildew and degradation associated with marine organisms. The materials used in the construction of the cable shall not be affected by continuous immersion in fresh or salt water.
- d. Selection of cable and fittings shall be made in a manner that ensures a safe design factor for mats being lifted from both ends, thereby forming a catenary. Consideration shall be taken for the bending of the cables around hooks or pins during lifting. Fittings such as sleeves and stops shall be aluminum and washers shall be plastic unless otherwise shown on the Contract Drawings.

2. Option 2. Galvanized Steel Revetment Cable and Fittings

- a. Revetment cable shall be constructed of preformed galvanized aircraft cable (GAC). The cables shall be made from individual wires and strands that have been formed during the manufacture into the shape they have in finished cable.
- b. Cable shall consist of a core construction comprised of seven (7) wires wrapped within seven (7) or nineteen (19) wire strands.
- c. The size of the revetment cable shall be selected such that the minimum acceptable strength is at least five (5) times that required for lifting of the mats, in accordance with ASTM D-6684 paragraph 5.5.2. This design shall include a reduction factor for splicing of 75%,

- unless a larger factor can be substantiated by laboratory testing.
- d. The revetment cable shall exhibit resistance to mild concentrations of acids, alkalis, and solvents. Fittings such as sleeves and stops shall be aluminum, and the washers shall be galvanized steel or plastic. Furthermore, depending on material availability, the cable type (7x7 or 7x19) can be interchanged while always ensuring the required factor of safety for the cable.
  - e. Selection of cable and fittings shall be made in a manner that insures a safe design factor for mats being lifted from both ends, thereby forming a catenary. Consideration shall be taken for the bending of the cables around hooks or pins during lifting. Fittings such as sleeves and stops shall be aluminum and washers shall be plastic unless otherwise shown on the Contract Drawings.
- C. Filter Fabric
- 1. The standard for sizing geotextile for these applications is AASHTO M-288, Permanent Erosion Control, Class 2. Either woven monofilament or non-woven geotextile are acceptable; woven slit-film geotextiles are not acceptable.
  - 2. Under no circumstances shall the filter fabric be permanently affixed or otherwise adhered to the blocks or mats; i.e., the filter fabric shall be independent of the block system.
  - 3. During all periods of shipment and storage, the filter fabric shall be protected from direct sunlight, UV radiation, and temperatures greater than 140°F. To the extent possible, the fabric shall be maintained wrapped in its protective covering. Geotextile exposure to sunlight or UV radiation shall be minimized to the greatest extent possible until the installation process begins.

## PART 2 EXECUTION

### 2.1 SUBGRADE PREPARATION

- A. All subgrade preparation shall be performed in accordance with the current version of ASTM D 6884, *Standard Practice for Installation of Articulating Concrete Block (ACB) Revetment Systems*.
- B. The slope shall be graded to a smooth plane surface to ensure that intimate contact is achieved between the slope face and the geotextile (filter fabric), and between the geotextile and the entire bottom surface of the individual ACBs. All slope deformities, roots, grade stakes, and stones which project normal to the local slope face must be re-graded or removed. No holes, "pockmarks", slope board teeth marks, footprints, or other voids greater than 0.5 inch in depth normal to the local slope face shall be permitted. No grooves or depressions greater than 0.5 inches in depth normal to the local slope face with a dimension exceeding 1.0 foot in any direction shall be permitted. Where such areas are evident, they shall be brought to grade by placing compacted homogeneous material. The slope and slope face shall be uniformly compacted, and the depth of layers, homogeneity of soil, and amount of compaction shall be as required by the EOR.
- C. Excavation and preparation for all termination trenches or aprons shall be done in accordance to the lines, grades and dimensions shown in the Contract Drawings. The termination trench hinge-point at the top of the slope shall be

uniformly graded so that no dips or bumps greater than 0.5 inches over or under the local grade occur. The width of the termination trench hinge-point shall also be graded uniformly to assure intimate contact between all ACBs and the underlying grade at the hinge-point.

- D. Immediately prior to placing the filter fabric and ACB mats, the prepared subgrade shall be inspected by the EOR as well as the owner's representative. No fabric or blocks shall be placed thereon until that area has been approved by each of these parties.

## 2.2 PLACEMENT OF GEOTEXTILE FILTER FABRIC

- A. All placement and preparation should be performed in accordance with the current version of ASTM D 6884, *Standard Practice for Installation of Articulating Concrete Block (ACB) Revetment Systems*. Filter Fabric, or filtration geotextile, as specified elsewhere, will be placed within the limits of ACBs shown on the Contract Drawings.
- B. The filtration geotextile will be placed directly on the prepared area, in intimate contact with the subgrade, and free of folds or wrinkles. The geotextile will not be walked on or disturbed when the result is a loss of intimate contact between the ACB and the geotextile or between the geotextile and the subgrade. The geotextile filter fabric will be placed so that the upstream strip of fabric overlaps the downstream strip. The longitudinal and transverse joints will be overlapped at least one and a half (1.5) feet for dry installations and at least three (3) feet for below-water installations. The geotextile will extend at least one (1) foot beyond the top and bottom revetment termination points, or as required by the EOR. If ACBs are assembled and placed as large mattresses, the top lap edge of the geotextile should not occur in the same location as a space between ACB mats unless the space is concrete filled.

## 2.3 PLACEMENT OF THE ACBs/MATS

- A. ACB placement and preparation should be performed in accordance with the current version of ASTM D 6884, *Standard Practice for Installation of Articulating Concrete Block (ACB) Revetment Systems*. ACB block/mats, as specified in Part 2:A of these Specifications, will be constructed within the specified lines and grades shown on the Contract Drawings.
- B. Field installation shall be consistent with the way the system was installed in preparation for hydraulic testing pursuant to the current version of ASTM D 7277, *Standard Test Method for Performance Testing of Articulating Concrete Block (ACB) Revetment Systems for Hydraulic Stability in Open Channel Flow*. Any external restraints, anchors, or other ancillary components (such as synthetic drainage mediums) shall be employed as they were during testing; e.g., if the hydraulic testing installation utilized a drainage layer, then the field installation must also utilize a drainage layer. This does not preclude the use of other section components for other purposes, e.g., a geogrid for strengthening the subgrade for vehicular loading, or an intermediate filter layer of sand to protect very fine-grained native soils.
- C. The subgrade shall be prepared in such a manner as to produce a smooth plane surface prior to placement of the ACBs or mats. No individual block

within the plane of placed ACBs will protrude more than 0.5 inches or as otherwise specified by the EOR. ACBs should be flush and develop intimate contact with the subgrade section, as approved by the EOR. Proposed hand placing is only to be used in limited areas, specifically identified by the EOR or manufacturers' mat layout drawings, as approved by the EOR.

- D. If assembled and placed as large mattresses, the ACB mats will be attached to a spreader bar or other approved device to aid in the lifting and placing of the mats in their proper position by the use of a crane or other approved equipment. The equipment used should have adequate capacity to place the mats without bumping, dragging, tearing or otherwise damaging the underlying fabric. The mats will be placed side-by-side, so that the mats abut each other, and/or end-to-end. Mat seams or openings between mats greater than two (2) inches will be backfilled with 4000 p.s.i. non-shrink grout, concrete or other material approved by the EOR. Whether placed by hand or in large mattresses, distinct changes in grade that results in a discontinuous revetment surface in the direction of flow will require backfill at the grade change location so as to produce a continuous surface.
- E. Termination trenches will be backfilled and compacted flush with the top of the blocks. The integrity of the trench backfill must be maintained so as to ensure a surface that is flush with the top surface of the ACBs for its entire service life. Termination trenches will be backfilled as shown on the Contract Drawings. Backfilling and compaction of trenches will be completed in a timely fashion. No more than 500 linear feet of placed ACBs with non-completed termination trenches will be permitted at any time.
- F. The cells or openings in the ACBs will be backfilled and compacted with suitable material, as specified by the EOR. Backfilling and compaction will be completed in a timely manner so that no more than 500 feet of exposed mats exist at any time. Finishing requirements are explicitly at the discretion of the EOR.
- G. The manufacturer of the ACBs/mats shall provide design and construction advice during the design and initial installation phases of the project when required or as necessary, at the discretion of the EOR. The ACB supplier shall provide, at a minimum, one full day or two half-days of on-site project support upon request.

END OF SECTION

## SP-17 TECHNICAL REQUIREMENTS AND SPECIFICATIONS

### USACE PERMITTING

---

---

#### PART 1 GENERAL

##### 1.1 SUMMARY

- A. Contractor shall follow all guidelines found in the attached Nationwide Permit.
- B. Contractor shall follow all components of the attached Aquatic Resource Protection Plan. All efforts and materials to follow the plan shall be paid under the **SWPPP Documentation and Management** line item. No separate payment shall be made.
- C. Contractor shall notify the engineer via email a minimum of two (2) weeks prior to mobilization for the construction project. The engineer shall initiate and complete flagging of specified locations prior to contractor arriving onsite.
- D. Contractor shall install T-posts at the flagged locations with orange construction barrier fencing and signs stating "Off Limits" or similar in nature to clearly define boundaries of wetlands. No separate payment shall be made.
- E. Contractor shall be responsible for acquiring a new Nationwide Permit if the construction timeline exceeds the expiration date of the attached Nationwide Permits.

ARJY